

Module 3

Learning unit 8: Interface

- We have four common types of memory:
 - Read only memory (ROM)
 - Flash memory (EEPROM)
 - Static Random access memory (SARAM)
 - Dynamic Random access memory (DRAM).
- Pin connections common to all memory devices are: The address input, data output or input/outputs, selection input and control input used to select a read or write operation.
- **Address connections:** All memory devices have address inputs that select a memory location within the memory device. Address inputs are labeled from A_0 to A_n .
- **Data connections:** All memory devices have a set of data outputs or input/outputs. Today many of them have bi-directional common I/O pins.
- **Selection connections:** Each memory device has an input, that selects or enables the memory device. This kind of input is most often called a chip select (\overline{CS}), chip enable (\overline{CE}) or simply select (\overline{S}) input.

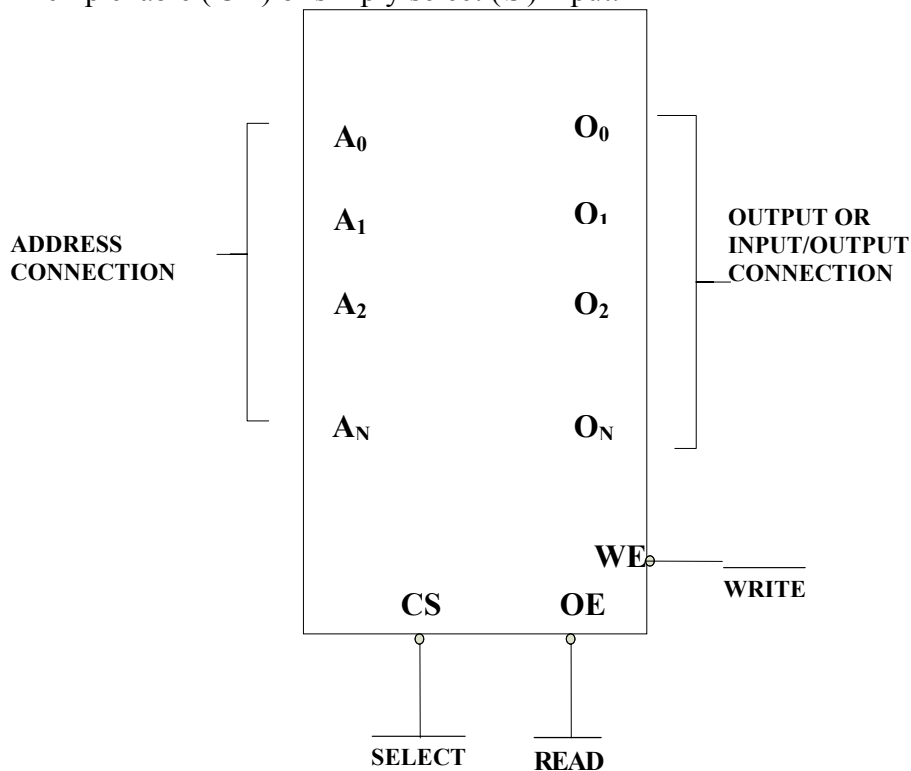

MEMORY COMPONENT ILLUSTRATING THE ADDRESS, DATA AND CONTROL CONNECTIONS

- RAM memory generally has at least one \overline{CS} or \overline{S} input and ROM at least one \overline{CE} .
- If the \overline{CE} , \overline{CS} , \overline{S} input is active the memory device perform the read or write.

- If it is inactive the memory device cannot perform read or write operation.
- If more than one \overline{CS} connection is present, all must be active to perform read or write data.
- **Control connections:** A ROM usually has only one control input, while a RAM often has one or two control inputs.
- The control input most often found on the ROM is the output enable (\overline{OE}) or gate (\overline{G}), this allows data to flow out of the output data pins of the ROM.
- If OE and the selected input are both active, then the output is enable, if OE is inactive, the output is disabled at its high-impedance state.
- The \overline{OE} connection enables and disables a set of three-state buffer located within the memory device and must be active to read data.
- A RAM memory device has either one or two control inputs. If there is one control input it is often called R/ \overline{W} .
- This pin selects a read operation or a write operation only if the device is selected by the selection input (\overline{CS}).
- If the RAM has two control inputs, they are usually labeled \overline{WE} or \overline{W} and \overline{OE} or \overline{G} .
- (\overline{WE}) write enable must be active to perform a memory write operation and OE must be active to perform a memory read operation.
- When these two controls \overline{WE} and \overline{OE} are present, they must never be active at the same time.
- The ROM read only memory permanently stores programs and data and data was always present, even when power is disconnected.
- It is also called as nonvolatile memory.
- EPROM (erasable programmable read only memory) is also erasable if exposed to high intensity ultraviolet light for about 20 minutes or less, depending upon the type of EPROM.
- We have PROM (programmable read only memory)
- RMM (read mostly memory) is also called the flash memory.
- The flash memory is also called as an EEPROM (electrically erasable programmable ROM), EAROM (electrically alterable ROM), or a NOVROM (nonvolatile ROM).
- These memory devices are electrically erasable in the system, but require more time to erase than a normal RAM.
- EPROM contains the series of 27XXX contains the following part numbers : 2704(512 * 8), 2708(1K * 8), 2716(2K * 8), 2732(4K * 8), 2764(8K * 8), 27128(16K * 8) etc.
- Each of these parts contains address pins, eight data connections, one or more chip selection inputs (\overline{CE}) and an output enable pin (\overline{OE}).
- This device contains **11** address inputs and **8** data outputs.
- If both the pin connection \overline{CE} and \overline{OE} are at logic 0, data will appear on the output connection . If both the pins are not at logic 0, the data output connections remains at their high impedance or off state.
- To read data from the EPROM Vpp pin must be placed at a logic 1.

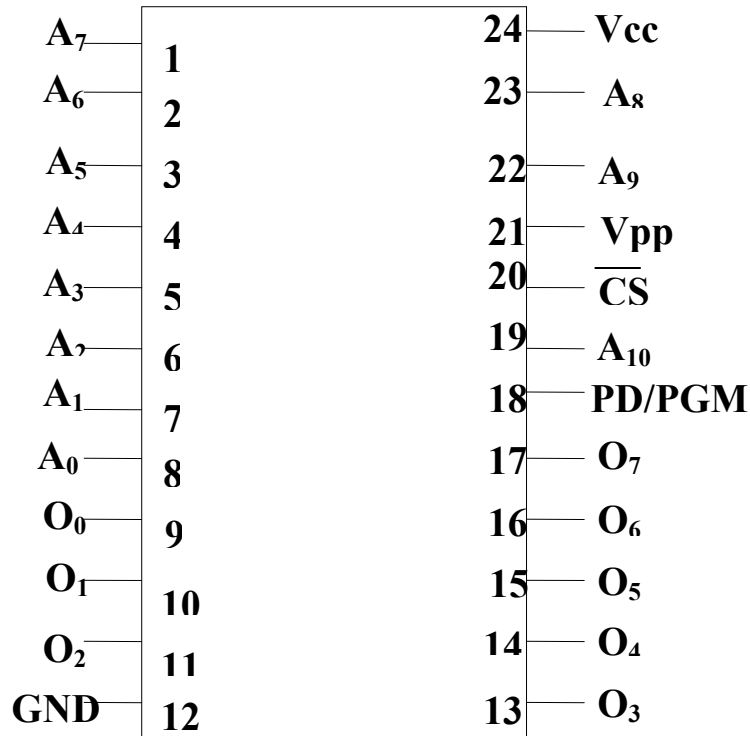

PIN CONFIGURATION OF 2716 EPROM

A₀ - A₁₀	ADDRESSES
PD/PGM	POWER DOWN / PROGRAM
$\overline{\text{CS}}$	CHIP SELECT
O₀-O₇	OUT PUTS

PIN NAMES

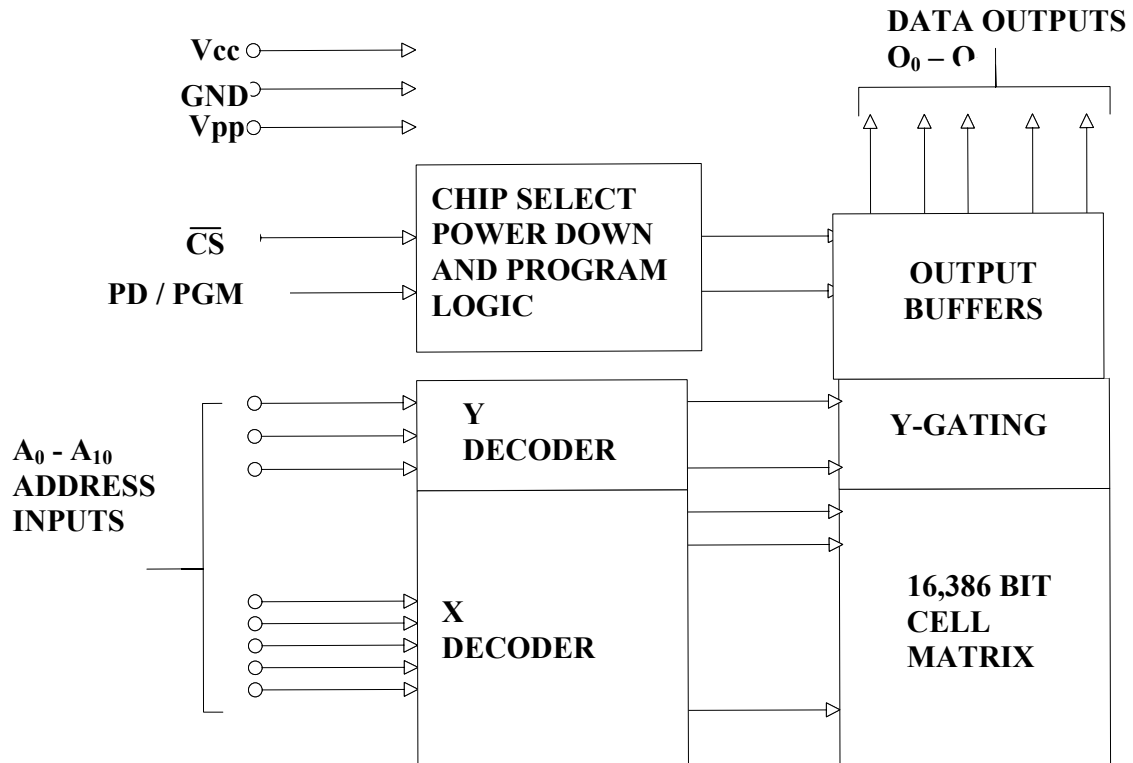

BLOCK DIAGRAM

- Static RAM memory device retain data for as long as DC power is applied. Because no special action is required to retain stored data, these devices are called as static memory. They are also called volatile memory because they will not retain data without power.
- The main difference between a ROM and RAM is that a RAM is written under normal operation, while ROM is programmed outside the computer and is only normally read.
- The SRAM stores temporary data and is used when the size of read/write memory is relatively small.

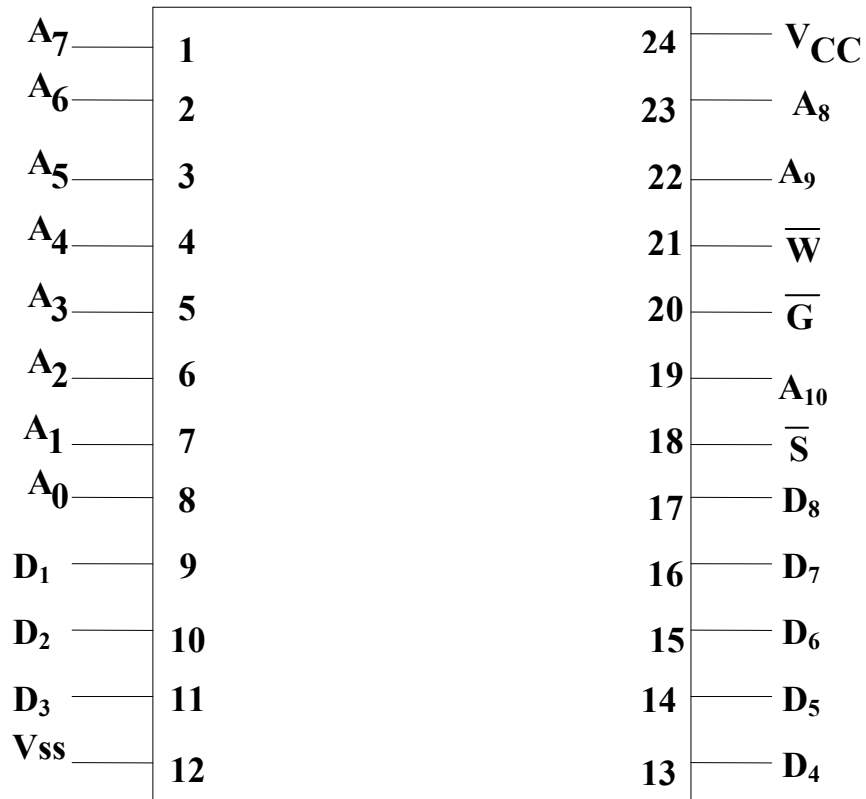

**PIN CONFIGURATION OF
4016SRAM**

$A_0 - A_{10}$	ADDRESSES
\overline{W}	WRITE ENABLE
\overline{S}	CHIP SELECT
$DQ_0 - DQ_8$	DATA IN / DATA OUT
\overline{G}	OUTPUT ENABLE
V_{ss}	GROUND
V_{cc}	+ 5 V SUPPLY

PIN NAMES

The control inputs of this RAM are slightly different from those presented earlier.

The \overline{OE} pin is labeled \overline{G} , the \overline{CS} pin \overline{S} and the \overline{WE} pin \overline{W} .

- This 4016 SRAM device has 11 address inputs and 8 data input/output connections.

Static RAM Interfacing

- The semiconductor RAM is broadly two types – Static RAM and Dynamic RAM.
- The semiconductor memories are organised as two dimensional arrays of memory locations.
- For example 4K * 8 or 4K byte memory contains 4096 locations, where each locations contains 8-bit data and only one of the 4096 locations can be selected at a time. Once a location is selected all the bits in it are accessible using a group of conductors called Data bus.
- For addressing the 4K bytes of memory, 12 address lines are required.
- In general to address a memory location out of N memory locations, we will require at least n bits of address, i.e. n address lines where $n = \log_2 N$.
- Thus if the microprocessor has n address lines, then it is able to address at the most N locations of memory, where $2^n = N$. If out of N locations only P memory locations are to be interfaced, then the least significant p address lines out of the available n lines can be directly connected from the microprocessor to the memory chip while the remaining (n-p) higher order address lines may be used for address decoding as inputs to the chip selection logic.
- The memory address depends upon the hardware circuit used for decoding the chip select (\overline{CS}). The output of the decoding circuit is connected with the \overline{CS} pin of the memory chip.

- The general procedure of static memory interfacing with 8086 is briefly described as follows:
 1. Arrange the available memory chip so as to obtain 16-bit data bus width. The upper 8-bit bank is called as odd address memory bank and the lower 8-bit bank is called as even address memory bank.
 2. Connect available memory address lines of memory chip with those of the microprocessor and also connect the memory \overline{RD} and \overline{WR} inputs to the corresponding processor control signals. Connect the 16-bit data bus of the memory bank with that of the microprocessor 8086.
 3. The remaining address lines of the microprocessor, BHE and A_0 are used for decoding the required chip select signals for the odd and even memory banks. The \overline{CS} of memory is derived from the o/p of the decoding circuit.
- As a good and efficient interfacing practice, the address map of the system should be continuous as far as possible, i.e. there should not be no windows in the map and no fold back space should be allowed.
- A memory location should have a single address corresponding to it, i.e. absolute decoding should be preferred and minimum hardware should be used for decoding.

Dynamic RAM

- Whenever a large capacity memory is required in a microcomputer system, the memory subsystem is generally designed using dynamic RAM because there are various advantages of dynamic RAM.
- E.g. higher packing density, lower cost and less power consumption. A typical static RAM cell may require six transistors while the dynamic RAM cell requires only a transistors along with a capacitor. Hence it is possible to obtain higher packaging density and hence low cost units are available.
- The basic dynamic RAM cell uses a capacitor to store the charge as a representation of data. This capacitor is manufactured as a diode that is reverse-biased so that the storage capacitance comes into the picture.
- This storage capacitance is utilized for storing the charge representation of data but the reverse-biased diode has leakage current that tends to discharge the capacitor giving rise to the possibility of data loss. To avoid this possible data loss, the data stored in a dynamic RAM cell must be refreshed after a fixed time interval regularly. The process of refreshing the data in RAM is called as **Refresh cycle**.
- The refresh activity is similar to reading the data from each and every cell of memory, independent of the requirement of microprocessor. During this refresh period all other operations related to the memory subsystem are suspended. Hence the refresh activity causes loss of time, resulting in reduce system performance.
- However keeping in view the advantages of dynamic RAM, like low power consumption, high packaging density and low cost, most of the advanced computing system are designed using dynamic RAM, at the cost of operating speed.
- A dedicated hardware chip called as dynamic RAM controller is the most important part of the interfacing circuit.

- The **Refresh cycle** is different from the memory read cycle in the following aspects.
 1. The memory address is not provided by the CPU address bus, rather it is generated by a refresh mechanism counter called as refresh counter.
 2. Unlike memory read cycle, more than one memory chip may be enabled at a time so as to reduce the number of total memory refresh cycles.
 3. The data enable control of the selected memory chip is deactivated, and data is not allowed to appear on the system data bus during refresh, as more than one memory units are refreshed simultaneously. This is to avoid the data from the different chips to appear on the bus simultaneously.
 4. Memory read is either a processor initiated or an external bus master initiated and carried out by the refresh mechanism.
- Dynamic RAM is available in units of several kilobits to megabits of memory. This memory is arranged internally in a two dimensional matrix array so that it will have n rows and m columns. The row address n and column address m are important for the refreshing operation.
- For example, a typical 4K bit dynamic RAM chip has an internally arranged bit array of dimension $64 * 64$, i.e. 64 rows and 64 columns. The row address and column address will require 6 bits each. These 6 bits for each row address and column address will be generated by the refresh counter, during the refresh cycles.
- A complete row of 64 cells is refreshed at a time to minimize the refreshing time. Thus the refresh counter needs to generate only row addresses. The row addresses are multiplexed, over lower order address lines.
- The refresh signals act to control the multiplexer, i.e. when refresh cycle is in process the refresh counter puts the row address over the address bus for refreshing. Otherwise, the address bus of the processor is connected to the address bus of DRAM, during normal processor initiated activities.
- A timer, called refresh timer, derives a pulse for refreshing action after each refresh interval.
- Refresh interval can be qualitatively defined as the time for which a dynamic RAM cell can hold data charge level practically constant, i.e. no data loss takes place.
- Suppose the typical dynamic RAM chip has 64 rows, then each row should be refreshed after each refresh interval or in other words, all the 64 rows are to be refreshed in a single refresh interval.
- This refresh interval depends upon the manufacturing technology of the dynamic RAM cell. It may range anywhere from 1ms to 3ms.
- Let us consider 2ms as a typical refresh time interval. Hence, the frequency of the refresh pulses will be calculated as follows:
 - Refresh Time (per row) $t_r = (2 * 10^{-3}) / 64$.
 - Refresh Frequency $f_r = 64 / (2 * 10^{-3}) = 32 * 10^3$ Hz.
- The following block diagram explains the refreshing logic and 8086 interfacing with dynamic RAM.
- Each chip is of 16K * 1-bit dynamic RAM cell array. The system contains two 16K byte dynamic RAM units. All the address and data lines are assumed to be available from an 8086 microprocessor system.

- The \overline{OE} pin controls output data buffer of the memory chips. The \overline{CE} pins are active high chip selects of memory chips. The refresh cycle starts, if the refresh output of the refresh timer goes high, \overline{OE} and \overline{CE} also tend to go high.
- The high \overline{CE} enables the memory chip for refreshing, while high \overline{OE} prevents the data from appearing on the data bus, as discussed in memory refresh cycle. The $16K \times 1$ -bit dynamic RAM has an internal array of 128×128 cells, requiring 7 bits for row address. The lower order seven lines A_0 - A_6 are multiplexed with the refresh counter output A_{10} - A_{16} .

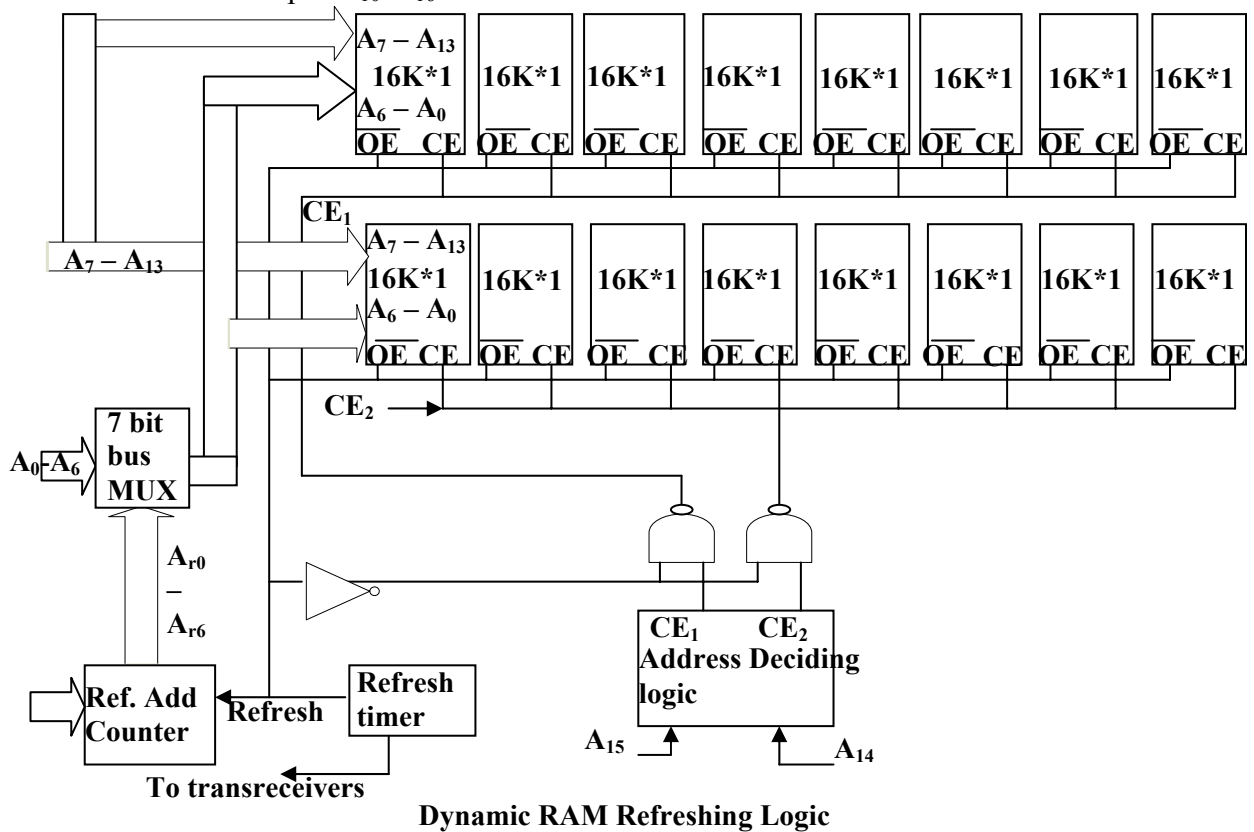

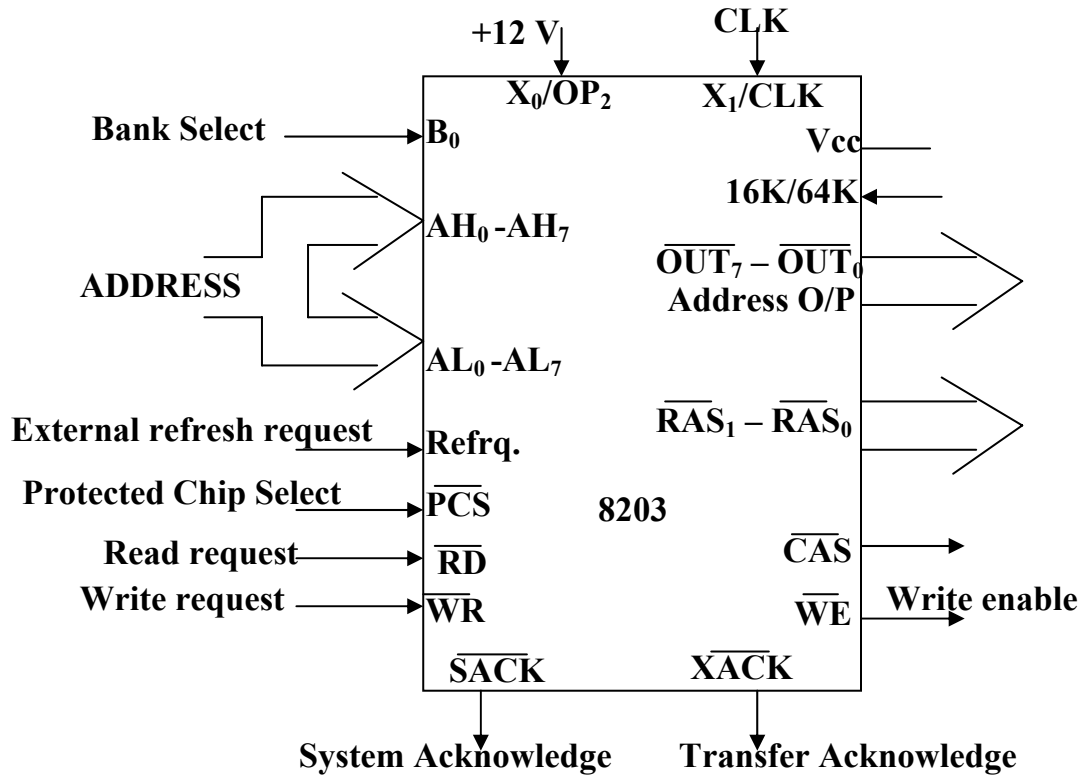

Fig : Dynamic RAM controller

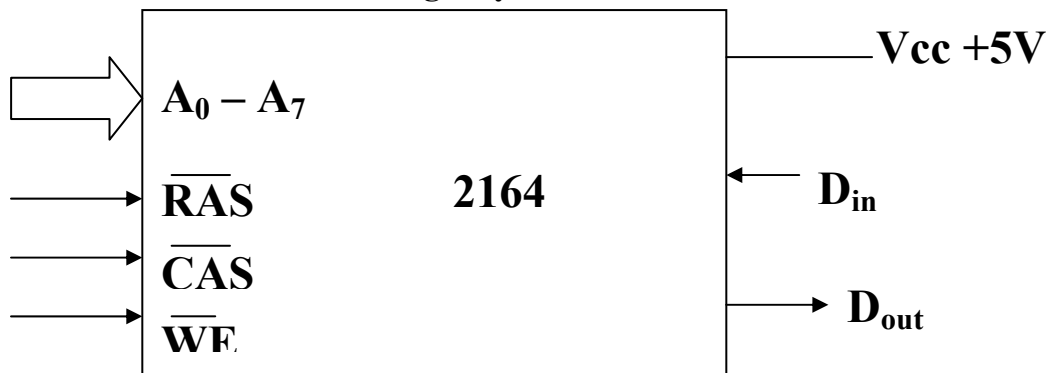

Fig : 1- bit Dynamic RAM

- The pin assignment for 2164 dynamic RAM is as in above fig.
- The \overline{RAS} and \overline{CAS} are row and column address strobes and are driven by the dynamic RAM controller outputs. $A_0 - A_7$ lines are the row or column address lines, driven by the $OUT_0 - OUT_7$ outputs of the controller. The \overline{WE} pin indicates memory write cycles. The D_{IN} and D_{OUT} pins are data pins for write and read operations respectively.
- In practical circuits, the refreshing logic is integrated inside dynamic RAM controller chips like 8203, 8202, 8207 etc.

- Intel's 8203 is a dynamic RAM controller that support 16K or 64K dynamic RAM chip. This selection is done using pin 16K/64K. If it is high, the 8203 is configured to control 16K dynamic RAM, else it controls 64K dynamic RAM. The address inputs of 8203 controller accepts address lines A_1 to A_{16} on lines AL_0 - AL_7 and AH_0 - AH_7 .
- The A_0 lines is used to select the even or odd bank. The \overline{RD} and \overline{WR} signals decode whether the cycle is a memory read or memory write cycle and are accepted as inputs to 8203 from the microprocessor.
- The \overline{WE} signal specifies the memory write cycle and is not output from 8203 that drives the WE input of dynamic RAM memory chip. The \overline{OUT}_0 – \overline{OUT}_7 set of eight pins is an 8-bit output bus that carries multiplexed row and column addresses are derived from the address lines A_1 - A_{16} accepted by the controller on its inputs AL_0 - AL_7 and AH_0 - AH_7 .
- An external crystal may be applied between X_0 and X_1 pins, otherwise with the OP_2 pin at +12V, a clock signal may be applied at pin CLK.
- The \overline{PCS} pin accepts the chip select signal derived by an address decoder. The REFREQ pin is used whenever the memory refresh cycle is to be initiated by an external signal.
- The \overline{XACK} signal indicates that data is available during a read cycle or it has been written if it is a write cycle. It can be used as a strobe for data latches or as a ready signal to the processor.
- The \overline{SACK} output signal marks the beginning of a memory access cycle.
- If a memory request is made during a memory refresh cycle, the \overline{SACK} signal is delayed till the starting of memory read or write cycle.
- Following fig shows the 8203 can be used to control a 256K bytes memory subsystem for a maximum mode 8086 microprocessor system.
- This design assumes that data and address busses are inverted and latched, hence the inverting buffers and inverting latches are used (8283-inverting buffer and 8287- inverting latch).

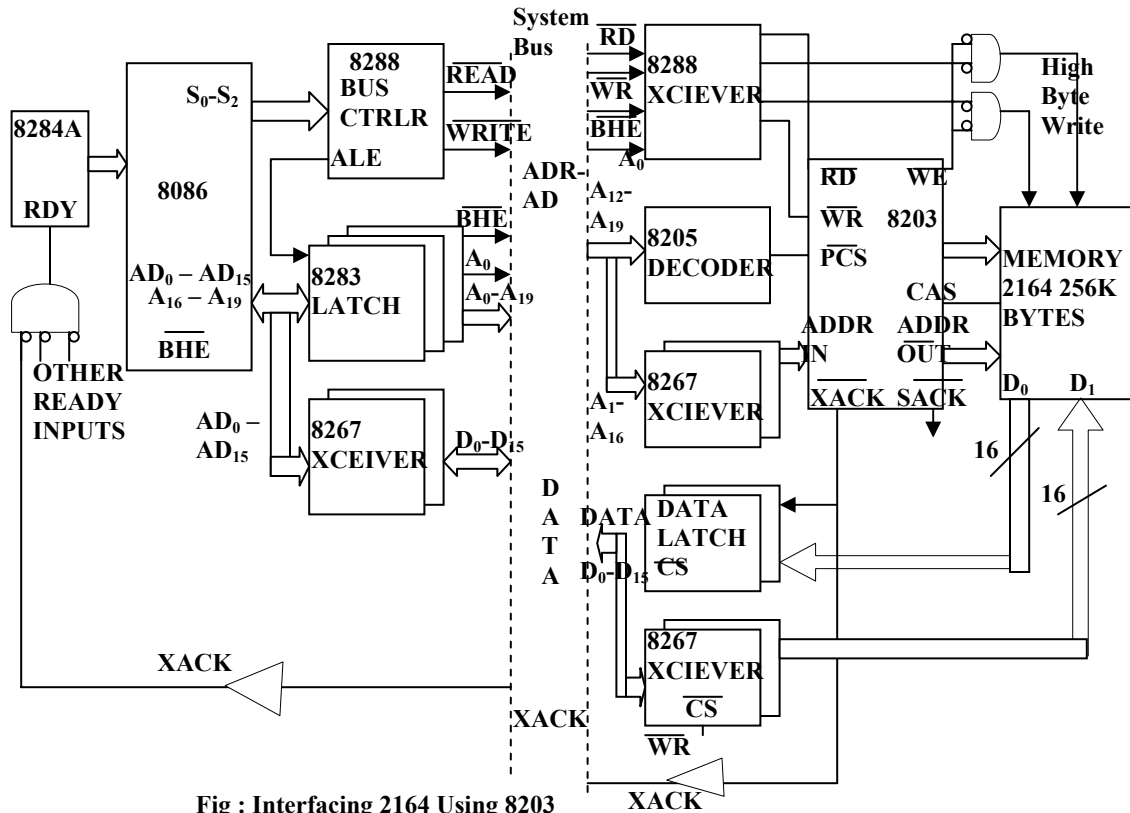

Fig : Interfacing 2164 Using 8203

- Most of the functions of 8208 and 8203 are similar but 8208 can be used to refresh the dynamic RAM using DMA approach. The memory system is divided into even and odd banks of 256K bytes each, as required for an 8086 system.
- The inverted \overline{AACK} output of 8208 latches the A_0 and \overline{BHE} signals required for selecting the banks. If the latched bank select signal and the $\overline{WE}/PCLK$ output of 8208 both become low. It indicates a write operation to the respective bank.

Module 3 learning unit 9:

PIO 8255

- The parallel input-output port chip 8255 is also called as programmable **peripheral input-output port**. The Intel's 8255 is designed for use with Intel's 8-bit, 16-bit and higher capability microprocessors. It has 24 input/output lines which may be individually programmed in two groups of twelve lines each, or three groups of eight lines.
- The two groups of I/O pins are named as Group A and Group B. Each of these two groups contains a subgroup of eight I/O lines called as 8-bit port and another subgroup of four lines or a 4-bit port. Thus Group A contains an 8-bit port A along with a 4-bit port C upper.
- The port A lines are identified by symbols PA_0-PA_7 while the port C lines are identified as PC_4-PC_7 . Similarly, Group B contains an 8-bit port B, containing lines PB_0-PB_7 and a 4-bit port C with lower bits PC_0-PC_3 . The port C upper and port C lower can be used in combination as an 8-bit port C.
- Both the port C are assigned the same address. Thus one may have either three 8-bit I/O ports or two 8-bit and two 4-bit ports from 8255. All of these ports can

- function independently either as input or as output ports. This can be achieved by programming the bits of an internal register of 8255 called as control word register (CWR).
- The internal block diagram and the pin configuration of 8255 are shown in fig.
 - The 8-bit data bus buffer is controlled by the read/write control logic. The read/write control logic manages all of the internal and external transfers of both data and control words.
 - \overline{RD} , \overline{WR} , A_1 , A_0 and RESET are the inputs provided by the microprocessor to the READ/ WRITE control logic of 8255. The 8-bit, 3-state bidirectional buffer is used to interface the 8255 internal data bus with the external system data bus.
 - This buffer receives or transmits data upon the execution of input or output instructions by the microprocessor. The control words or status information is also transferred through the buffer.
 - The signal description of 8255 are briefly presented as follows :
 - **PA₇-PA₀**: These are eight port A lines that acts as either latched output or buffered input lines depending upon the control word loaded into the control word register.
 - **PC₇-PC₄** : Upper nibble of port C lines. They may act as either output latches or input buffers lines.
 - This port also can be used for generation of handshake lines in mode 1 or mode 2.
 - **PC₃-PC₀** : These are the lower port C lines, other details are the same as PC₇-PC₄ lines.
 - **PB₀-PB₇** : These are the eight port B lines which are used as latched output lines or buffered input lines in the same way as port A.
 - **\overline{RD}** : This is the input line driven by the microprocessor and should be low to indicate read operation to 8255.
 - **\overline{WR}** : This is an input line driven by the microprocessor. A low on this line indicates write operation.
 - **\overline{CS}** : This is a chip select line. If this line goes low, it enables the 8255 to respond to \overline{RD} and \overline{WR} signals, otherwise \overline{RD} and \overline{WR} signal are neglected.
 - **A₁-A₀** : These are the address input lines and are driven by the microprocessor. These lines A₁-A₀ with \overline{RD} , \overline{WR} and \overline{CS} from the following operations for 8255. These address lines are used for addressing any one of the four registers, i.e. three ports and a control word register as given in table below.
 - In case of 8086 systems, if the 8255 is to be interfaced with lower order data bus, the A₀ and A₁ pins of 8255 are connected with A₁ and A₂ respectively.
 - **D₀-D₇** : These are the data bus lines those carry data or control word to/from the microprocessor.
 - **RESET** : A logic high on this line clears the control word register of 8255. All ports are set as input ports by default after reset.

$\overline{\text{RD}}$	$\overline{\text{WR}}$	$\overline{\text{CS}}$	A_1	A_0	Input (Read) cycle
0	1	0	0	0	Port A to Data bus
0	1	0	0	1	Port B to Data bus
0	1	0	1	0	Port C to Data bus
0	1	0	1	1	CWR to Data bus

$\overline{\text{RD}}$	$\overline{\text{WR}}$	$\overline{\text{CS}}$	A_1	A_0	Output (Write) cycle
1	0	0	0	0	Data bus to Port A
1	0	0	0	1	Data bus to Port B
1	0	0	1	0	Data bus to Port C
1	0	0	1	1	Data bus to CWR

$\overline{\text{RD}}$	$\overline{\text{WR}}$	$\overline{\text{CS}}$	A_1	A_0	Function
X	X	1	X	X	Data bus tristated
1	1	0	X	X	Data bus tristated

Control Word Register

Block Diagram of 8255 (Architecture)

- It has a 40 pins of 4 groups.
 1. Data bus buffer
 2. Read Write control logic
 3. Group A and Group B controls
 4. Port A, B and C
- **Data bus buffer:** This is a tristate bidirectional buffer used to interface the 8255 to system databus. Data is transmitted or received by the buffer on execution of input or output instruction by the CPU.
- Control word and status information are also transferred through this unit.
- **Read/Write control logic:** This unit accepts control signals ($\overline{\text{RD}}$, $\overline{\text{WR}}$) and also inputs from address bus and issues commands to individual group of control blocks (Group A, Group B).
- It has the following pins.
 - a) $\overline{\text{CS}}$ – Chipselect : A low on this PIN enables the communication between CPU and 8255.
 - b) $\overline{\text{RD}}$ (Read) – A low on this pin enables the CPU to read the data in the ports or the status word through data bus buffer.

- c) \overline{WR} (Write) : A low on this pin, the CPU can write data on to the ports or on to the control register through the data bus buffer.
- d) **RESET**: A high on this pin clears the control register and all ports are set to the input mode
- e) **A₀** and **A₁** (Address pins): These pins in conjunction with \overline{RD} and \overline{WR} pins control the selection of one of the 3 ports.
 - **Group A and Group B controls** : These block receive control from the CPU and issues commands to their respective ports.
 - Group A - PA and PCU (PC₇ – PC₄)
 - Group B - PCL (PC₃ – PC₀)
 - Control word register can only be written into no read operation of the CW register is allowed.
 - a) **Port A**: This has an 8 bit latched/buffered O/P and 8 bit input latch. It can be programmed in 3 modes – mode 0, mode 1, mode 2.
 - b) **Port B**: This has an 8 bit latched / buffered O/P and 8 bit input latch. It can be programmed in mode 0, mode 1.
 - c) **Port C** : This has an 8 bit latched input buffer and 8 bit out put latched/buffer. This port can be divided into two 4 bit ports and can be used as control signals for port A and port B. it can be programmed in mode 0.

Modes of Operation of 8255

- These are two basic modes of operation of 8255. I/O mode and Bit Set-Reset mode (BSR).
- In I/O mode, the 8255 ports work as programmable I/O ports, while in BSR mode only port C (PC₀-PC₇) can be used to set or reset its individual port bits.
- Under the I/O mode of operation, further there are three modes of operation of 8255, so as to support different types of applications, mode 0, mode 1 and mode 2.
- **BSR Mode**: In this mode any of the 8-bits of port C can be set or reset depending on D₀ of the control word. The bit to be set or reset is selected by bit select flags D₃, D₂ and D₁ of the CWR as given in table.
- **I/O Modes** :
 - a) **Mode 0 (Basic I/O mode)**: This mode is also called as basic input/output mode. This mode provides simple input and output capabilities using each of the three ports. Data can be simply read from and written to the input and output ports respectively, after appropriate initialisation.

D₃	D₂	D₁	Selected bits of port C
0	0	0	D₀
0	0	1	D₁
0	1	0	D₂
0	1	1	D₃
1	0	0	D₄
1	0	1	D₅
1	1	0	D₆
1	1	1	D₇

BSR Mode : CWR Format

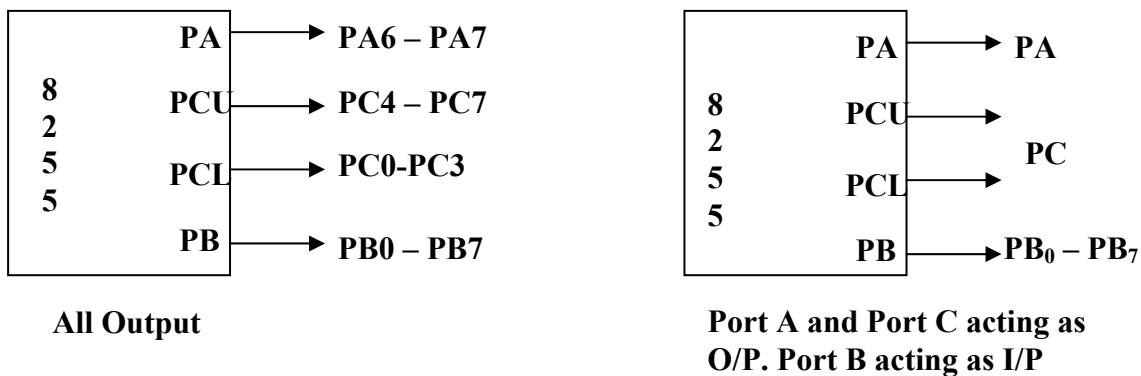

Mode 0

- The salient features of this mode are as listed below:
 - Two 8-bit ports (port A and port B) and two 4-bit ports (port C upper and lower) are available. The two 4-bit ports can be combinedly used as a third 8-bit port.
 - Any port can be used as an input or output port.
 - Output ports are latched. Input ports are not latched.
 - A maximum of four ports are available so that overall 16 I/O configurations are possible.
- All these modes can be selected by programming a register internal to 8255 known as CWR.
- The control word register has two formats. The first format is valid for I/O modes of operation, i.e. modes 0, mode 1 and mode 2 while the second format is valid for bit set/reset (BSR) mode of operation. These formats are shown in following fig.

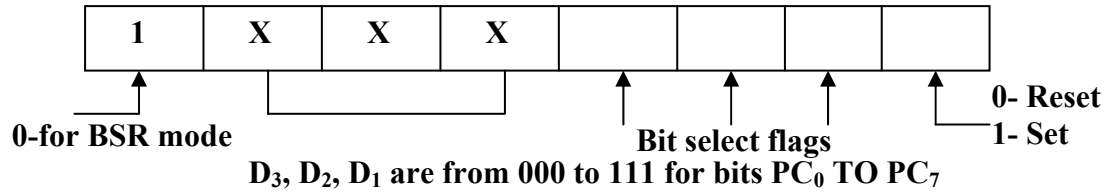

**I/O Mode Control Word Register Format and
BSR Mode Control Word Register Format**

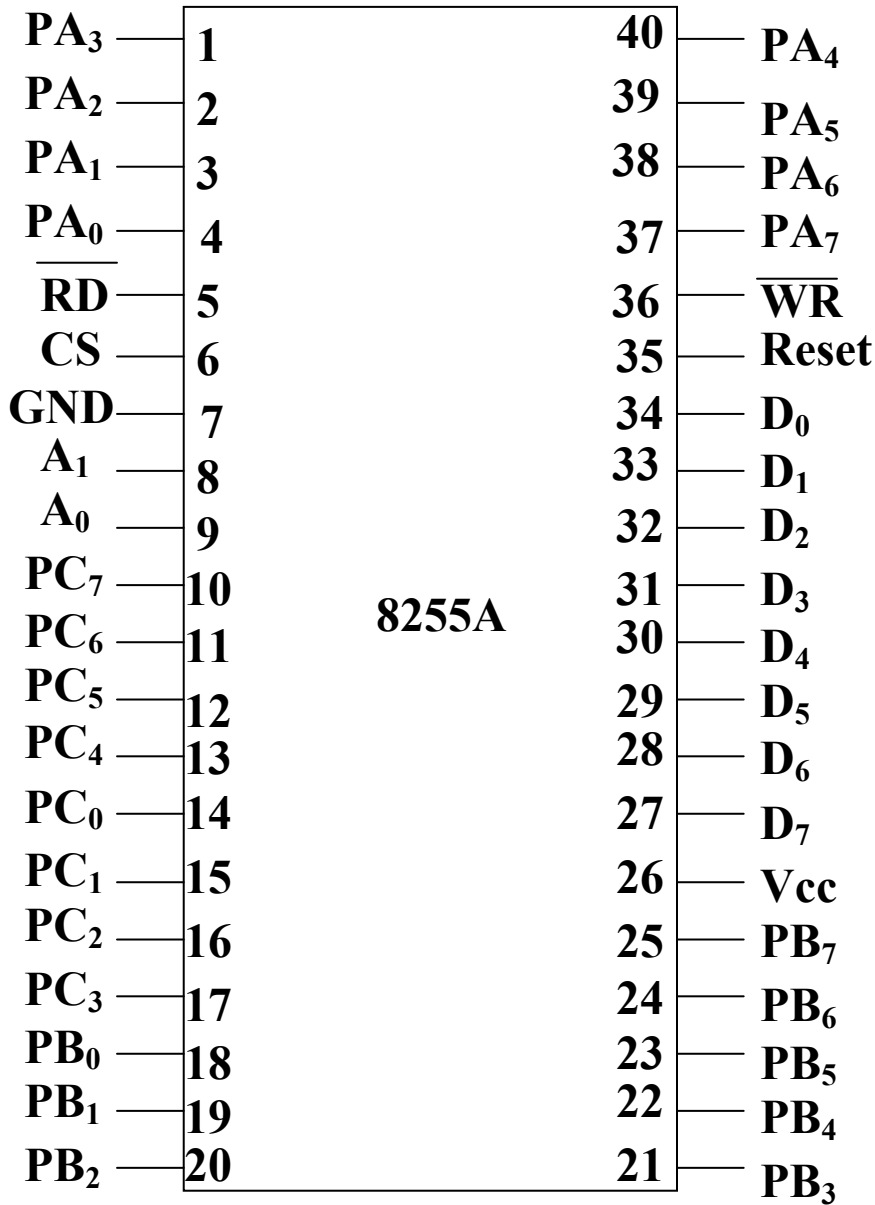

8255A Pin Configuration

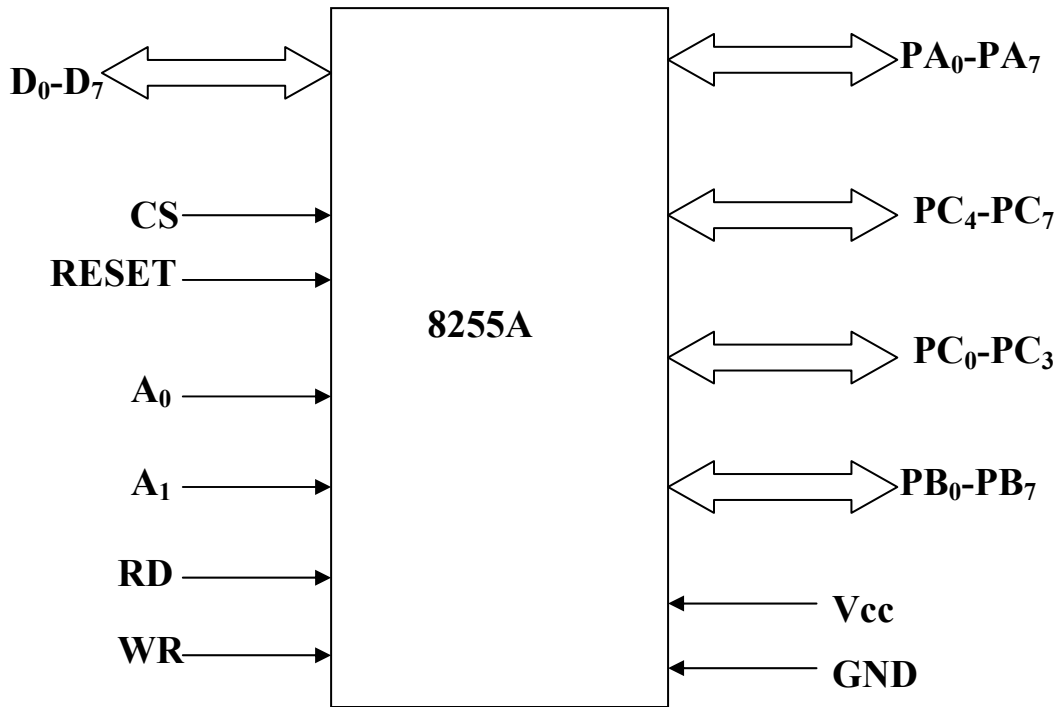

Signals of 8255

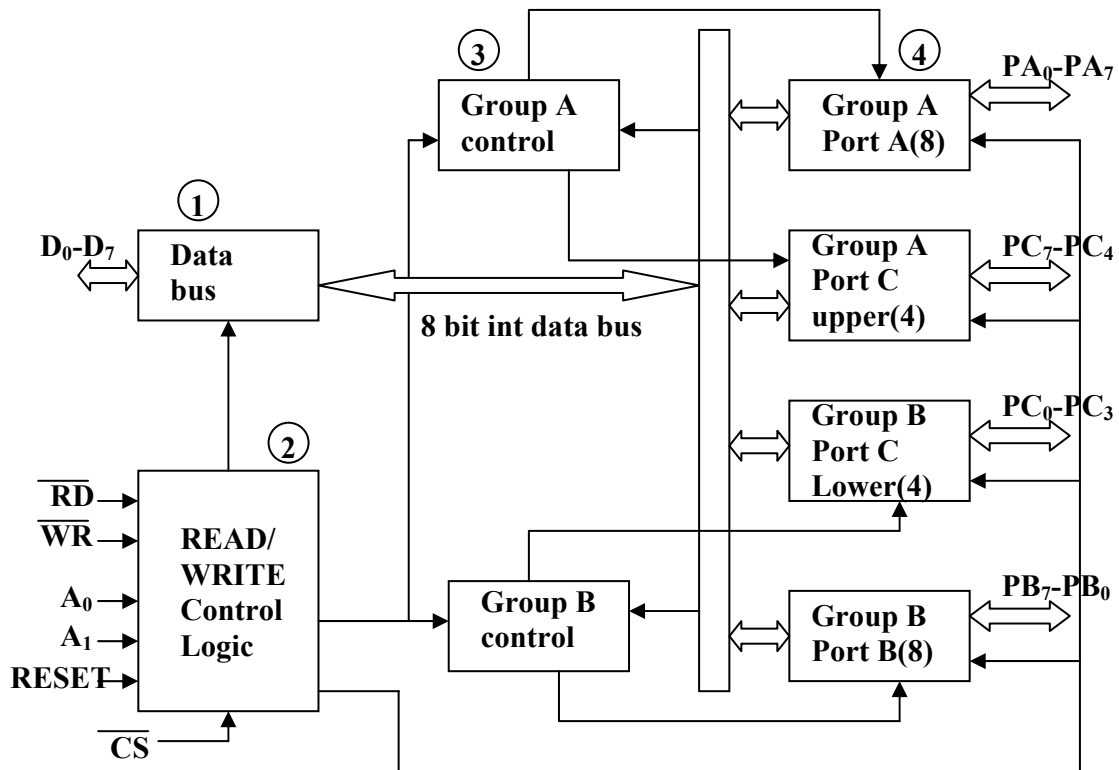

Block Diagram of 8255

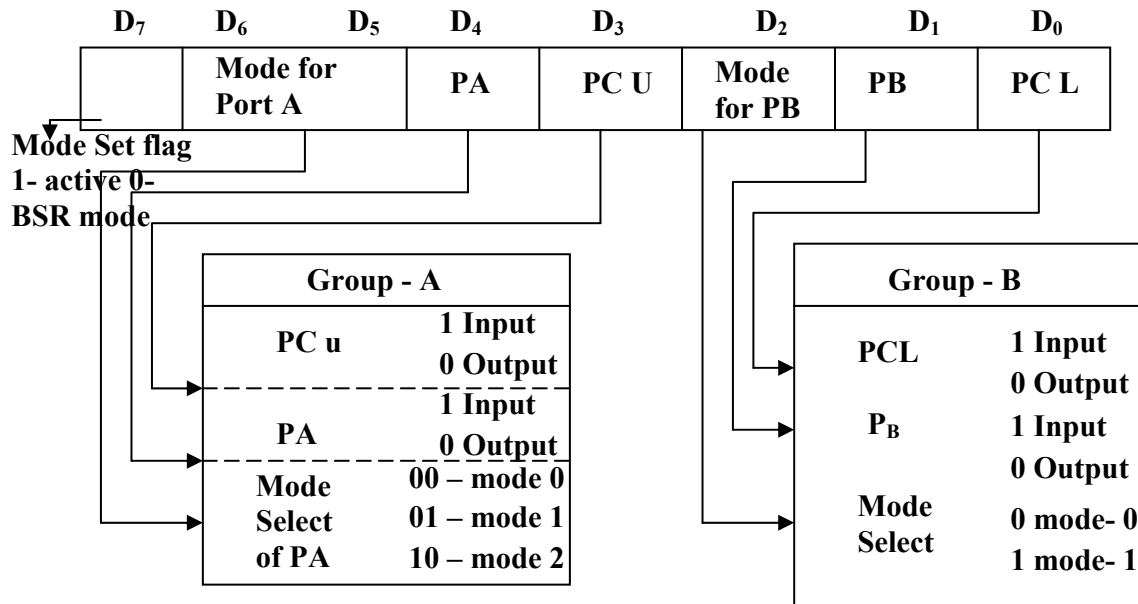

Control Word Format of 8255

b) Mode 1: (Strobed input/output mode) In this mode the handshaking control the input and output action of the specified port. Port C lines PC0-PC2, provide strobe or handshake lines for port B. This group which includes port B and PC0-PC2 is called as group B for Strobed data input/output. Port C lines PC3-PC5 provide strobe lines for port A.

This group including port A and PC3-PC5 from group A. Thus port C is utilized for generating handshake signals. The salient features of mode 1 are listed as follows:

1. Two groups – group A and group B are available for strobed data transfer.
 2. Each group contains one 8-bit data I/O port and one 4-bit control/data port.
 3. The 8-bit data port can be either used as input and output port. The inputs and outputs both are latched.
 4. Out of 8-bit port C, PC0-PC2 are used to generate control signals for port B and PC3-PC5 are used to generate control signals for port A. the lines PC6, PC7 may be used as independent data lines.
- **The control signals for both the groups in input and output modes are explained as follows:**

Input control signal definitions (mode 1):

- \overline{STB} (Strobe input) – If this lines falls to logic low level, the data available at 8-bit input port is loaded into input latches.
- **IBF** (Input buffer full) – If this signal rises to logic 1, it indicates that data has been loaded into latches, i.e. it works as an acknowledgement. IBF is set by a low on \overline{STB} and is reset by the rising edge of \overline{RD} input.
- **INTR** (Interrupt request) – This active high output signal can be used to interrupt the CPU whenever an input device requests the service. INTR is set by a high

STB pin and a high at IBF pin. INTE is an internal flag that can be controlled by the bit set/reset mode of either PC4(INTEA) or PC2(INTEB) as shown in fig.

- INTR is reset by a falling edge of RD input. Thus an external input device can be request the service of the processor by putting the data on the bus and sending the strobe signal.

Output control signal definitions (mode 1) :

- **OBF** (Output buffer full) – This status signal, whenever falls to low, indicates that CPU has written data to the specified output port. The OBF flip-flop will be set by a rising edge of \overline{WR} signal and reset by a low going edge at the \overline{ACK} input.
- **ACK** (Acknowledge input) – \overline{ACK} signal acts as an acknowledgement to be given by an output device. \overline{ACK} signal, whenever low, informs the CPU that the data transferred by the CPU to the output device through the port is received by the output device.
- **INTR** (Interrupt request) – Thus an output signal that can be used to interrupt the CPU when an output device acknowledges the data received from the CPU. INTR is set when ACK, OBF and INTE are 1. It is reset by a falling edge on WR input. The INTEA and INTEB flags are controlled by the bit set-reset mode of PC6 and PC2 respectively.

Input control signal definitions in Mode 1

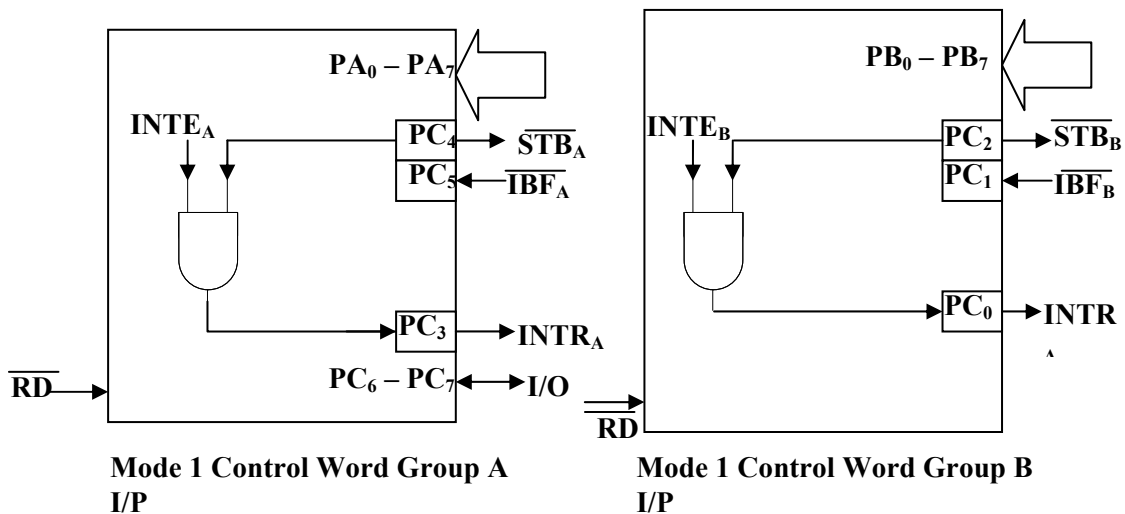
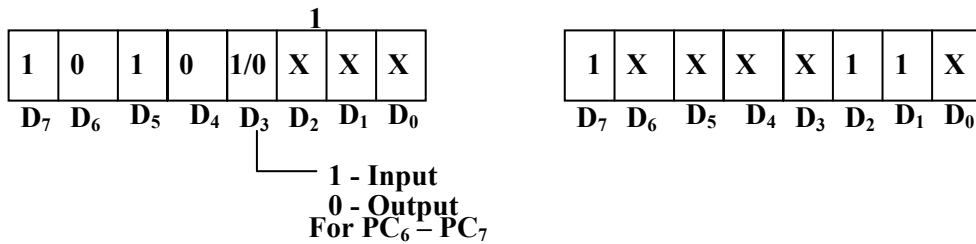

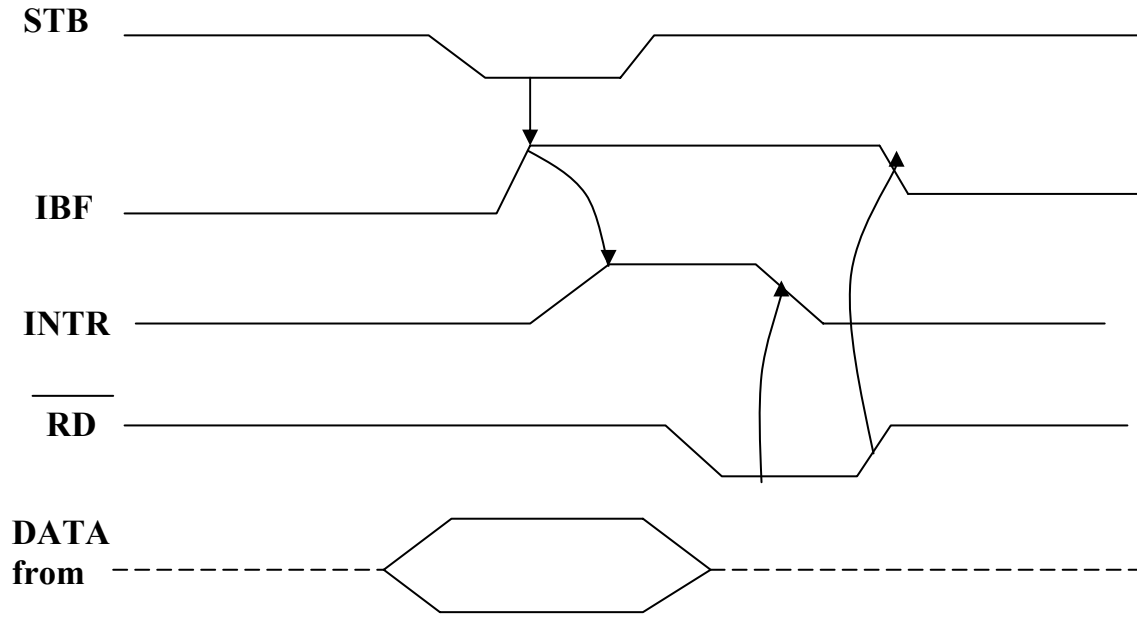

Mode 1 Strobed Input Data Transfer

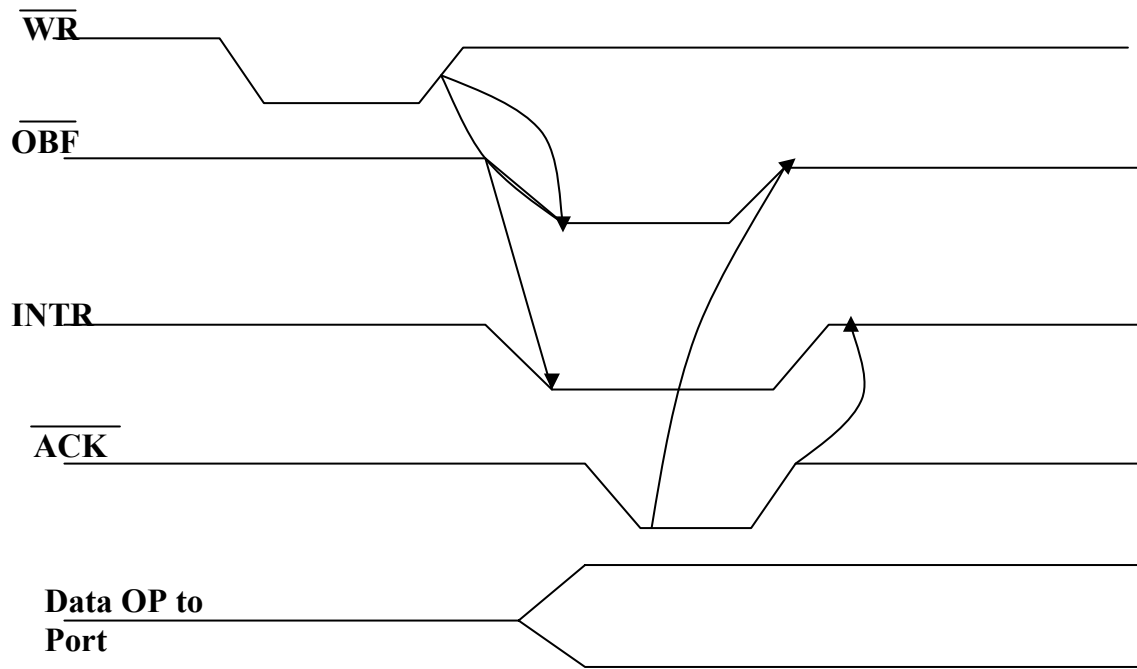

Mode 1 Strobed Data Output

Output control signal definitions Mode 1

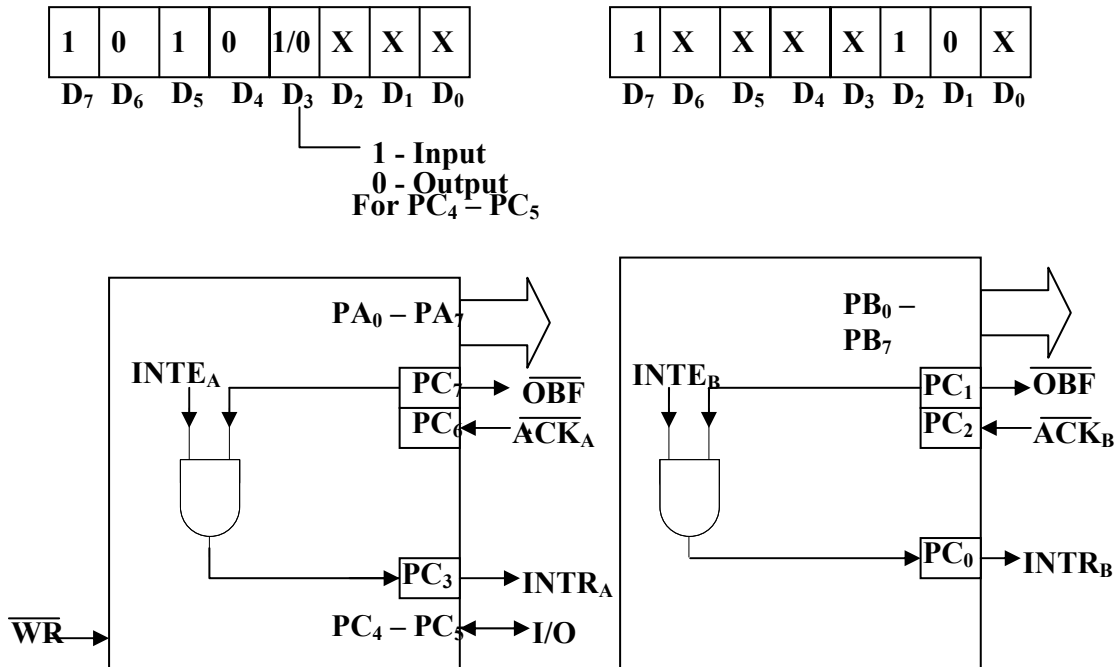

Mode 1 Control Word Group A

Mode 1 Control Word Group B

- **Mode 2 (Strobed bidirectional I/O):** This mode of operation of 8255 is also called as strobed bidirectional I/O. This mode of operation provides 8255 with an additional features for communicating with a peripheral device on an 8-bit data bus. Handshaking signals are provided to maintain proper data flow and synchronization between the data transmitter and receiver. The interrupt generation and other functions are similar to mode 1.
- In this mode, 8255 is a bidirectional 8-bit port with handshake signals. The Rd and WR signals decide whether the 8255 is going to operate as an input port or output port.
- The Salient features of Mode 2 of 8255 are listed as follows:
 1. The single 8-bit port in group A is available.
 2. The 8-bit port is bidirectional and additionally a 5-bit control port is available.
 3. Three I/O lines are available at port C.(PC2 – PC0)
 4. Inputs and outputs are both latched.
 5. The 5-bit control port C (PC3-PC7) is used for generating / accepting handshake signals for the 8-bit data transfer on port A.
- **Control signal definitions in mode 2:**
- **INTR** – (Interrupt request) As in mode 1, this control signal is active high and is used to interrupt the microprocessor to ask for transfer of the next data byte to/from it. This signal is used for input (read) as well as output (write) operations.
- **Control Signals for Output operations:**
- **OBF** (Output buffer full) – This signal, when falls to low level, indicates that the CPU has written data to port A.

- $\overline{\text{ACK}}$ (Acknowledge) This control input, when falls to logic low level, acknowledges that the previous data byte is received by the destination and next byte may be sent by the processor. This signal enables the internal tristate buffers to send the next data byte on port A.
- **INTE1** (A flag associated with OBF) This can be controlled by bit set/reset mode with PC6.
- **Control signals for input operations :**
- $\overline{\text{STB}}$ (Strobe input) A low on this line is used to strobe in the data into the input latches of 8255.
- **IBF** (Input buffer full) When the data is loaded into input buffer, this signal rises to logic '1'. This can be used as an acknowledge that the data has been received by the receiver.
- The waveforms in fig show the operation in Mode 2 for output as well as input port.
- Note: $\overline{\text{WR}}$ must occur before $\overline{\text{ACK}}$ and $\overline{\text{STB}}$ must be activated before $\overline{\text{RD}}$.

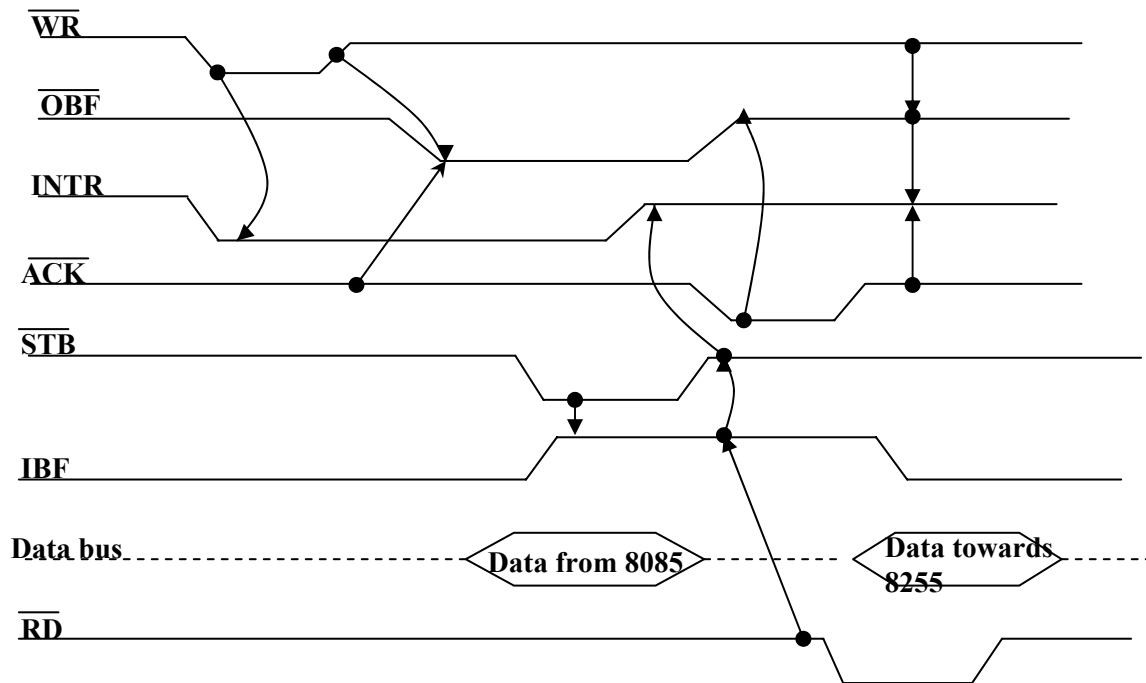

Mode 2 Bidirectional Data Transfer

- The following fig shows a schematic diagram containing an 8-bit bidirectional port, 5-bit control port and the relation of INTR with the control pins. Port B can either be set to Mode 0 or 1 with port A(Group A) is in Mode 2.
- Mode 2 is not available for port B. The following fig shows the control word.
- The INTR goes high only if either IBF , INTE2 , $\overline{\text{STB}}$ and $\overline{\text{RD}}$ go high or $\overline{\text{OBF}}$, INTE1 , $\overline{\text{ACK}}$ and $\overline{\text{WR}}$ go high. The port C can be read to know the status of the peripheral device, in terms of the control signals, using the normal I/O instructions.

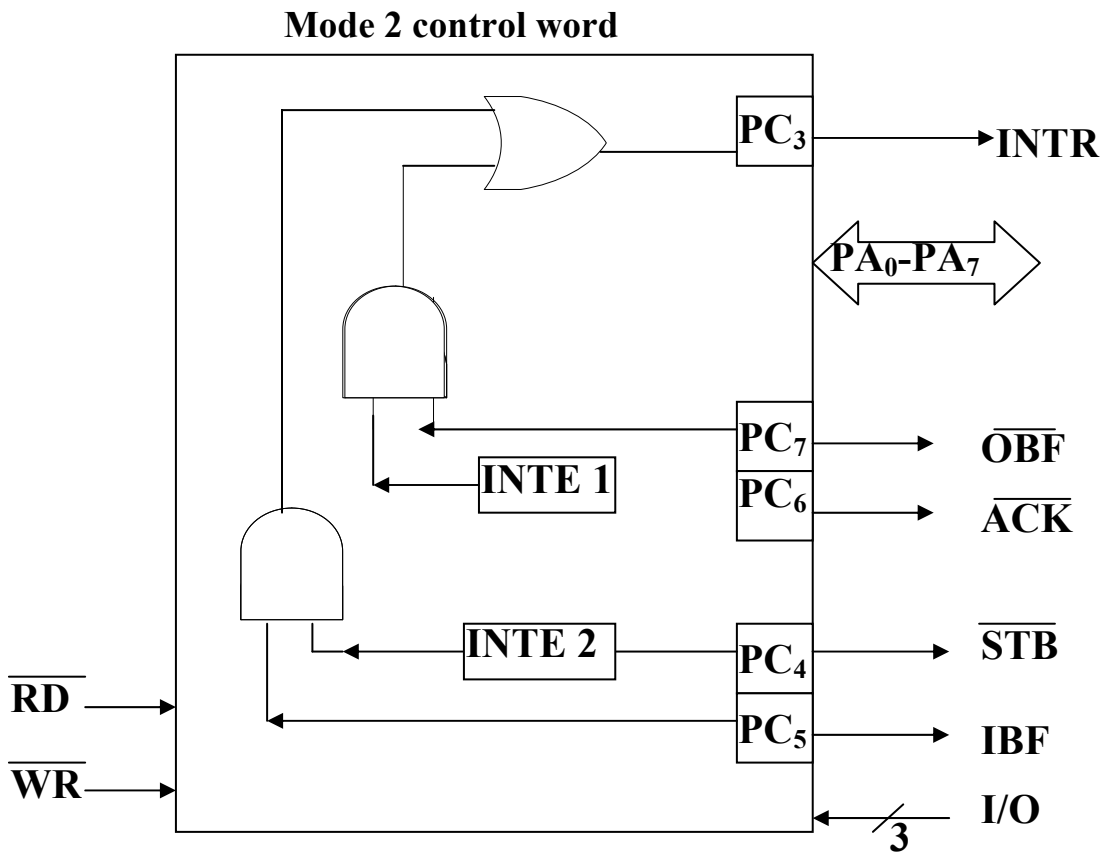
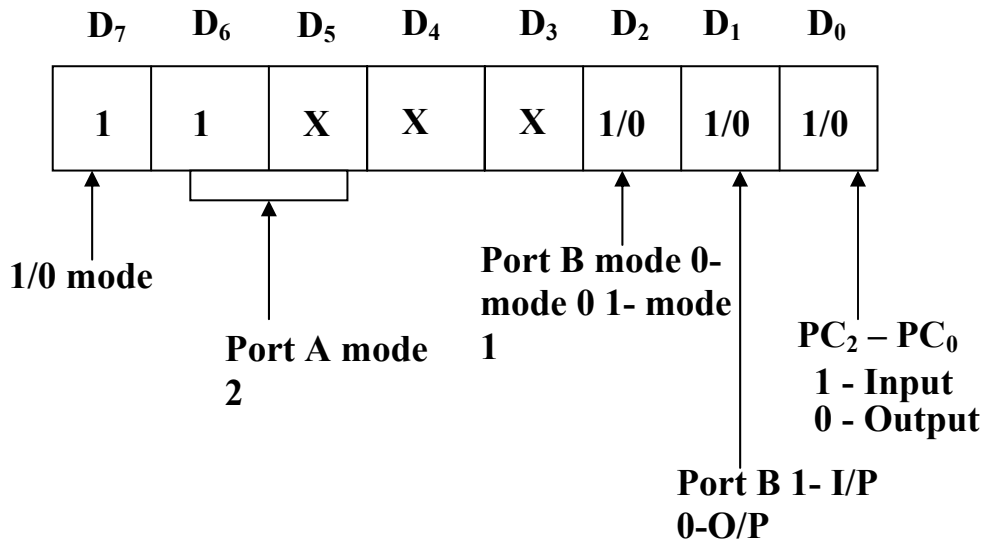

Mode 2 pins

8254

- Compatible with All Intel and Most other Microprocessors
- Handles Inputs from DC to 10 MHz
- 8 MHz 8254
- 10 MHz 8254-2
- Status Read-Back Command
- Six Programmable Counter Modes
- Three Independent 16-Bit Counters
- Binary or BCD Counting
- Single a 5V Supply
- Standard Temperature Range
- The Intel 8254 is a counter/timer device designed to solve the common timing control problems in microcomputer system design.
- It provides three independent 16-bit counters, each capable of handling clock inputs up to 10 MHz.
- All modes are software programmable. The 8254 is a superset of the 8253. The 8254 uses HMOS technology and comes in a 24-pin plastic or CERDIP package.

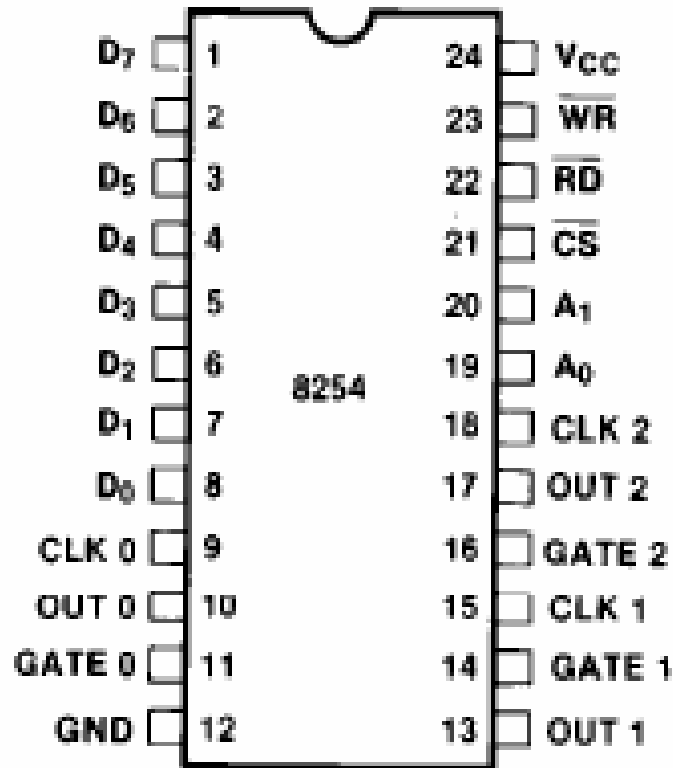

Figure 1. Pin Configuration

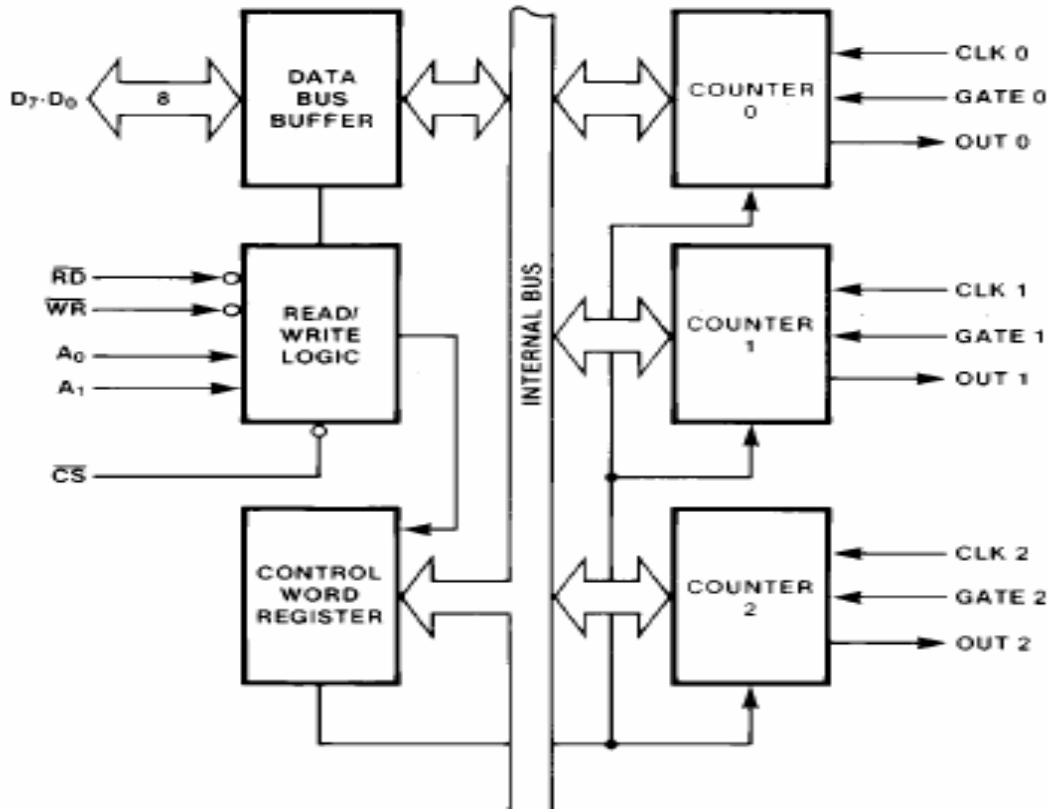

Figure 2. 8254 Block

Pin Description

Symbol	Pin No.	Type	Name and Function
D7-D0	1 - 8	I/O	DATA: Bi-directional three state data bus lines, connected to system data bus.
CLK 0	9	I	CLOCK 0: Clock input of Counter 0.
OUT 0	10	O	OUTPUT 0: Output of Counter 0.
GATE 0	11	I	GATE 0: Gate input of Counter 0.
GND	12		GROUND: Power supply connection.
VCC	24		POWER: A 5V power supply connection.
$\overline{\text{WR}}$	23	I	WRITE CONTROL: This input is low during CPU write operations.
RD	22	I	READ CONTROL: This input is low during CPU read operations.

CS	21	I	CHIP SELECT: A low on this input enables the 8254 to respond to RD and WR signals. RD and WR are ignored otherwise.		
A1, A0	20 – 9	I	ADDRESS: Used to select one of the three Counters or the Control Word Register for read or write operations. Normally connected to the system address bus.		
			A1	A0	Selects
			0	0	Counter 0
			0	1	Counter 1
			1	0	Counter 2
			1	1	Control Word Register
CLK 2	18	I	CLOCK 2: Clock input of Counter 2.		
OUT 2	17	O	OUT 2: Output of Counter 2.		
GATE 2	16	I	GATE 2: Gate input of Counter 2.		
CLK 1	15	I	CLOCK 1: Clock input of Counter 1.		
GATE 1	14	I	GATE 1: Gate input of Counter 1.		
OUT 1	OUT 1	O	OUT 1: Output of Counter 1.		

Functional Description

- The 8254 is a programmable interval timer/counter designed for use with Intel microcomputer systems.
- It is a general purpose, multi-timing element that can be treated as an array of I/O ports in the system software.
- The 8254 solves one of the most common problems in any microcomputer system, the generation of accurate time delays under software control. Instead of setting up timing loops in software, the programmer configures the 8254 to match his requirements and programs one of the counters for the desired delay.
- After the desired delay, the 8254 will interrupt the CPU. Software overhead is minimal and variable length delays can easily be accommodated.
- Some of the other counter/timer functions common to microcomputers which can be implemented with the 8254 are:
 - Real time clock
 - Event-counter
 - Digital one-shot
 - Programmable rate generator
 - Square wave generator

- Binary rate multiplier
- Complex waveform generator
- Complex motor controller

Block Diagram

- **DATA BUS BUFFER:** This 3-state, bi-directional, 8-bit buffer is used to interface the 8254 to the system bus, see the figure : Block Diagram Showing Data Bus Buffer and Read/Write Logic Functions.
- **READ/WRITE LOGIC :** The Read/Write Logic accepts inputs from the system bus and generates control signals for the other functional blocks of the 8254. A1 and A0 select one of the three counters or the Control Word Register to be read from/written into.
- A "low" on the RD input tells the 8254 that the CPU is reading one of the counters.

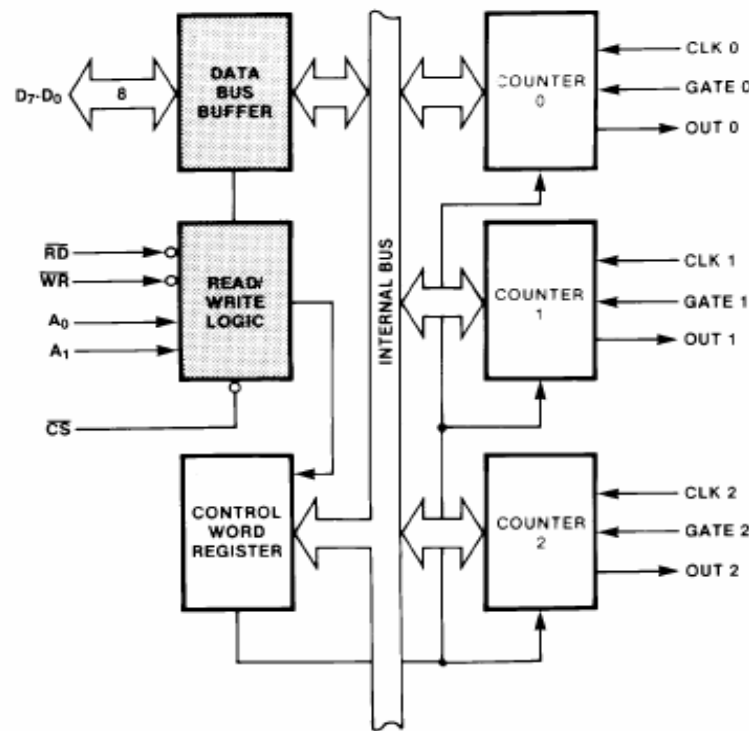

Figure 3. Block Diagram Showing Data Bus Buffer and Read/Write Logic Functions

- A "low" on the WR input tells the 8254 that the CPU is writing either a Control Word or an initial count. Both RD and WR are qualified by CS; RD and WR are ignored unless the 8254 has been selected by holding CS low.
- **CONTROL WORD REGISTER :** The Control Word Register (see Figure 4) is selected by the Read/Write Logic when $A_1, A_0 = 11$. If the CPU then does a write operation to the 8254, the data is stored in the Control Word Register and is interpreted as a Control Word used to define the operation of the Counters.

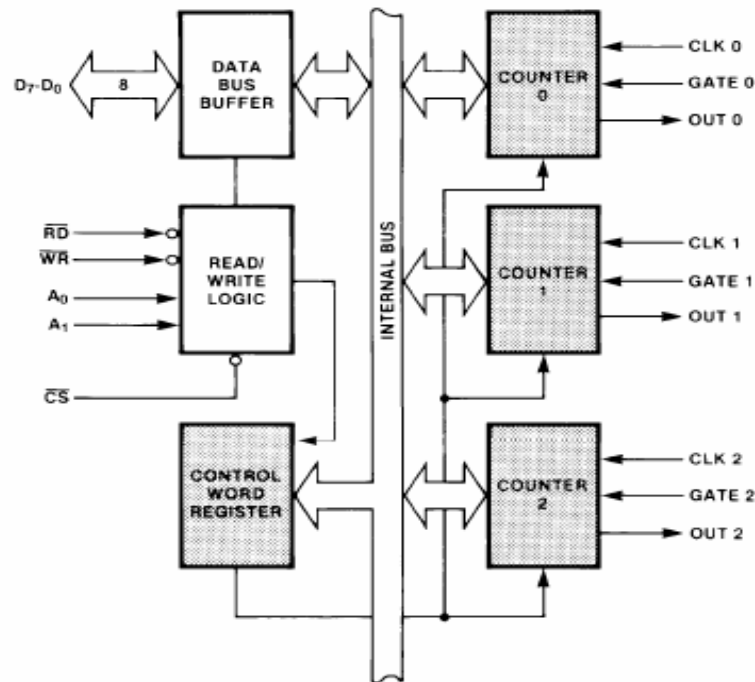

Figure 4. Block Diagram Showing Control Word Register and Counter Functions

- The Control Word Register can only be written to; status information is available with the Read-Back Command.
- **COUNTER 0, COUNTER 1, COUNTER 2** :These three functional blocks are identical in operation, so only a single Counter will be described. The internal block diagram of a single counter is shown in Figure 5.
- The Counters are fully independent. Each Counter may operate in a different Mode.
- The Control Word Register is shown in the figure, it is not part of the Counter itself, but its contents determine how the Counter operates.
- The status register, shown in Figure 5, when latched, contains the current contents of the Control Word Register and status of the output and null count flag. (See detailed explanation of the Read-Back command.)
- The actual counter is labelled CE (for "Counting Element"). It is a 16-bit presetable synchronous down counter. OLM and OLL are two 8-bit latches. OL stands for "Output Latch"; the subscripts M and L stand for "Most significant byte" and "Least significant byte" respectively.

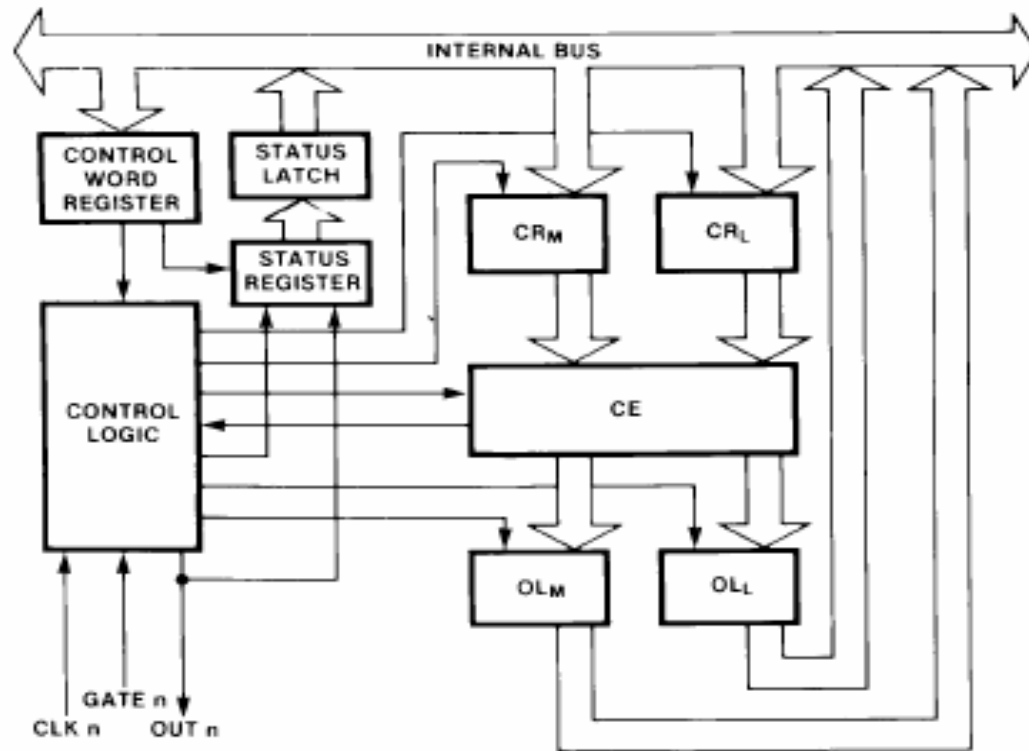

Figure 5. Internal Block Diagram of a Counter

- Both are normally referred to as one unit and called just OL. These latches normally ``follow'' the CE, but if a suitable Counter Latch Command is sent to the 8254, the latches ``latch'' the present count until read by the CPU and then return to ``following'' the CE.
- One latch at a time is enabled by the counter's Control Logic to drive the internal bus. This is how the 16-bit Counter communicates over the 8-bit internal bus. Note that the CE itself cannot be read; whenever you read the count, it is the OL that is being read.
- Similarly, there are two 8-bit registers called CRM and CRL (for ``Count Register"). Both are normally referred to as one unit and called just CR.
- When a new count is written to the Counter, the count is stored in the CR and later transferred to the CE. The Control Logic allows one register at a time to be loaded from the internal bus. Both bytes are transferred to the CE simultaneously.
- CRM and CRL are cleared when the Counter is programmed. In this way, if the Counter has been programmed for one byte counts (either most significant byte only or least significant byte only) the other byte will be zero.
- Note that the CE cannot be written into, whenever a count is written, it is written into the CR.
- The Control Logic is also shown in the diagram.
- CLK n, GATE n, and OUT n are all connected to the outside world through the Control Logic.

- **8254 SYSTEM INTERFACE:** The 8254 is a component of the Intel Microcomputer Systems and interfaces in the same manner as all other peripherals of the family.
- It is treated by the system's software as an array of peripheral I/O ports; three are counters and the fourth is a control register for MODE programming.
- Basically, the select inputs A₀,A₁ connect to the A₀,A₁ address bus signals of the CPU. The CS can be derived directly from the address bus using a linear select method. Or it can be connected to the output of a decoder, such as an Intel 8205 for larger systems.
- **Programming the 8254: Counters** are programmed by writing a Control Word and then an initial count.
- The Control Words are written into the Control Word Register, which is selected when A₁,A₀ = 11. The Control Word itself specifies which Counter is being programmed.

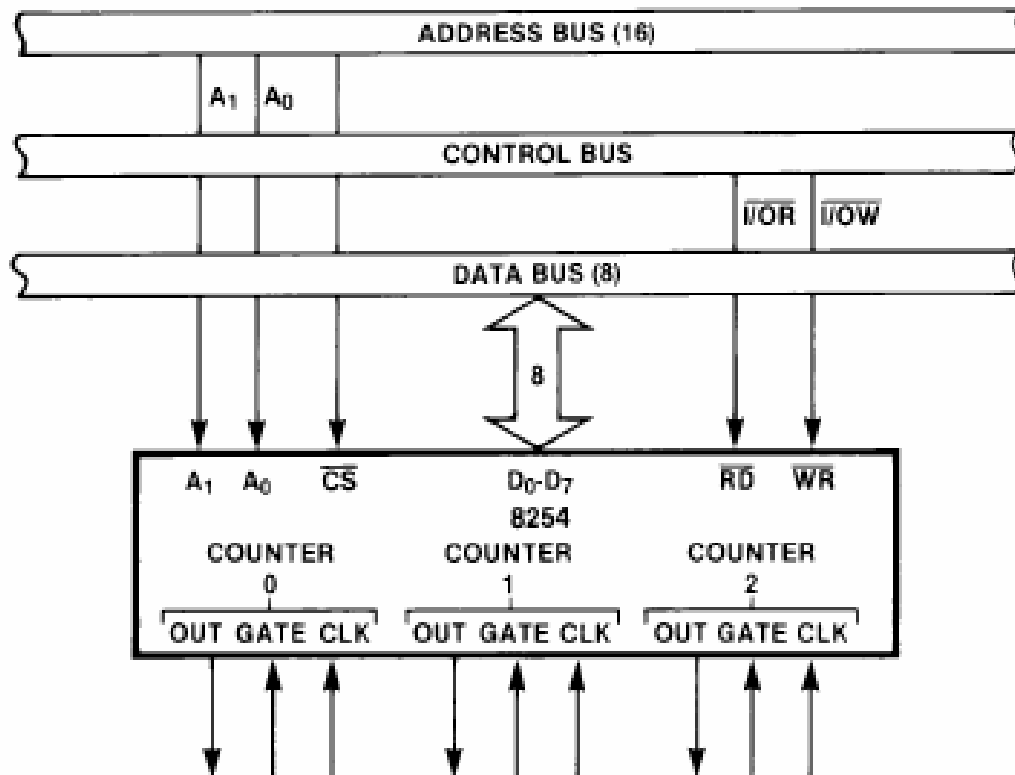

Figure 6. 8254 System Interface

- **Control Word Format:** A₁,A₀ = 11, CS = 0, RD = 1, WR = 0.
- By contrast, initial counts are written into the Counters, not the Control Word Register. The A₁,A₀ inputs are used to select the Counter to be written into. The format of the initial count is determined by the Control Word used.
- **Write Operations:** The programming procedure for the 8254 is very flexible. Only two conventions need to be remembered:
 - 1) For each Counter, the Control Word must be written before the initial count is written.

2) The initial count must follow the count format specified in the Control Word (least significant byte only, most significant byte only, or least significant byte and then most significant byte).

- Since the Control Word Register and the three Counters have separate addresses (selected by the A_1, A_0 inputs), and each Control Word specifies the Counter it applies to (SC_0, SC_1 bits), no special instruction sequence is required.
- Any programming sequence that follows the conventions in Figure 7 is acceptable.

D ₇	D ₆	D ₅	D ₄	D ₃	D ₂	D ₁	D ₀
SC ₁	SC ₀	RW ₁	RW ₀	M ₂	M ₁	M ₀	BCD

SC—Select Counter
SC₁ SC₀

SC ₁	SC ₀	
0	0	Select Counter 0
0	1	Select Counter 1
1	0	Select Counter 2
1	1	Read-Back Command (see Read Operations)

M—Mode

M ₂	M ₁	M ₀	
0	0	0	Mode 0
0	0	1	Mode 1
X	1	0	Mode 2
X	1	1	Mode 3
1	0	0	Mode 4
1	0	1	Mode 5

RW—Read/Write
RW₁ RW₀

RW ₁	RW ₀	
0	0	Counter Latch Command (see Read Operations)
0	1	Read/Write least significant byte only
1	0	Read/Write most significant byte only
1	1	Read/Write least significant byte first, then most significant byte

BCD

BCD	
0	Binary Counter 16-bits
1	Binary Coded Decimal (BCD) Counter (4 Decades)

NOTE: Don't care bits (X) should be 0 to insure compatibility with future Intel products.

Figure 7. Control Word Format

- A new initial count may be written to a Counter at any time without affecting the Counter's programmed Mode in any way. Counting will be affected as described in the Mode definitions. The new count must follow the programmed count format.
- If a Counter is programmed to read/write two-byte counts, the following precaution applies: A program must not transfer control between writing the first and second byte to another routine which also writes into that same Counter. Otherwise, the Counter will be loaded with an incorrect count.

	A₁	A₀		A₁	A₀
Control Word—Counter 0	1	1	Control Word—Counter 2	1	1
LSB of count—Counter 0	0	0	Control Word—Counter 1	1	1
MSB of count—Counter 0	0	0	Control Word—Counter 0	1	1
Control Word—Counter 1	1	1	LSB of count—Counter 2	1	0
LSB of count—Counter 1	0	1	MSB of count—Counter 2	1	0
MSB of count—Counter 1	0	1	LSB of count—Counter 1	0	1
Control Word—Counter 2	1	1	MSB of count—Counter 1	0	1
LSB of count—Counter 2	1	0	LSB of count—Counter 0	0	0
MSB of count—Counter 2	1	0	MSB of count—Counter 0	0	0
	A₁	A₀		A₁	A₀
Control Word—Counter 0	1	1	Control Word—Counter 1	1	1
Control Word—Counter 1	1	1	Control Word—Counter 0	1	1
Control Word—Counter 2	1	1	LSB of count—Counter 1	0	1
LSB of count—Counter 2	1	0	Control Word—Counter 2	1	1
LSB of count—Counter 1	0	1	LSB of count—Counter 0	0	0
LSB of count—Counter 0	0	0	MSB of count—Counter 1	0	1
MSB of count—Counter 0	0	0	LSB of count—Counter 2	1	0
MSB of count—Counter 1	0	1	MSB of count—Counter 0	0	0
MSB of count—Counter 2	1	0	MSB of count—Counter 2	1	0

Figure 8. A Few Possible Programming Sequences

- **Read Operations:** It is often desirable to read the value of a Counter without disturbing the count in progress. This is easily done in the 8254.
- There are three possible methods for reading the counters: a simple read operation, the Counter Latch Command, and the Read-Back Command.
- Each is explained below. The first method is to perform a simple read operation. To read the Counter, which is selected with the A₁, A₀ inputs, the CLK input of the selected Counter must be inhibited by using either the GATE input or external logic.
- Otherwise, the count may be in the process of changing when it is read, giving an undefined result.
- **COUNTER LATCH COMMAND:** The second method uses the "Counter Latch Command".
- Like a Control Word, this command is written to the Control Word Register, which is selected when A₁, A₀ = 11. Also like a Control Word, the SC₀, SC₁ bits select one of the three Counters, but two other bits, D₅ and D₄, distinguish this command from a Control Word.
- The selected Counter's output latch (OL) latches the count at the time the Counter Latch Command is received. This count is held in the latch until it is read by the CPU (or until the Counter is reprogrammed).

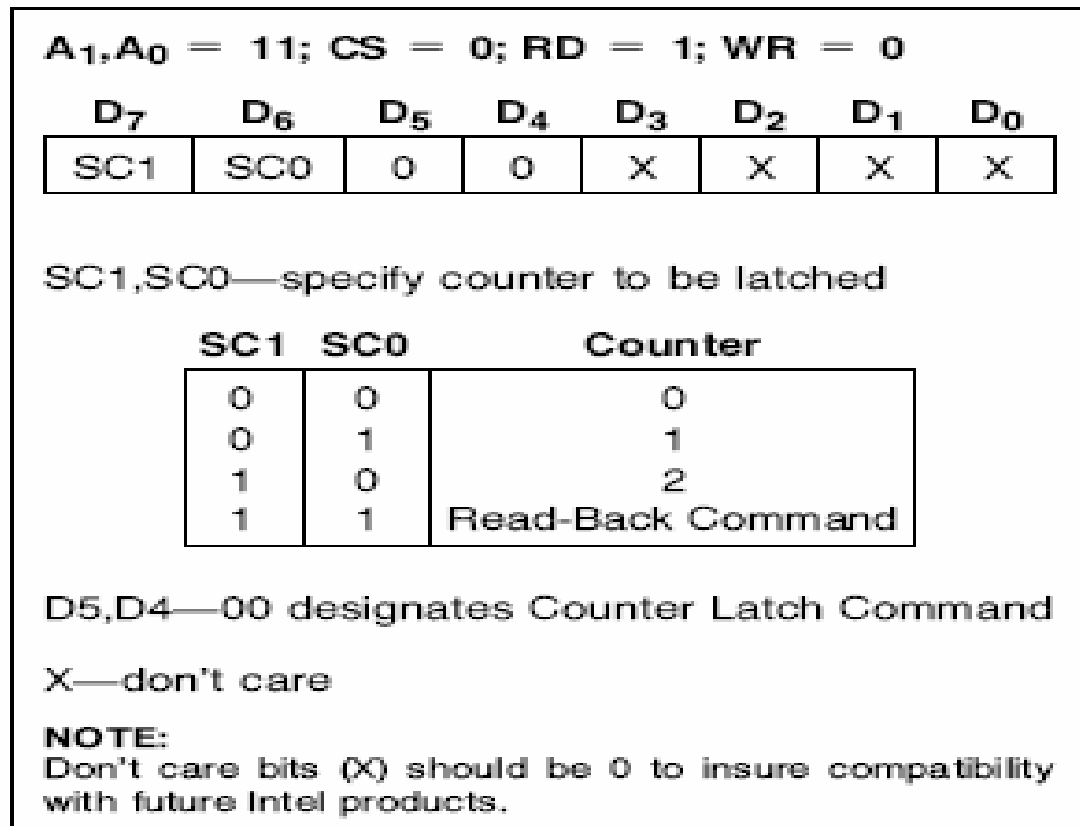
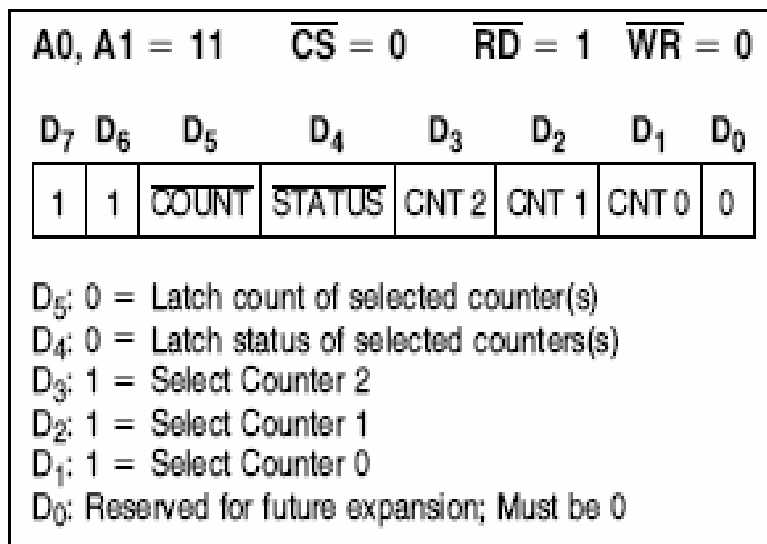

Figure 9. Counter Latching Command Format

- The count is then unlatched automatically and the OL returns to "following" the counting element (CE).
- This allows reading the contents of the Counters "on the fly" without affecting counting in progress.
- Multiple Counter Latch Commands may be used to latch more than one Counter. Each latched Counter's OL holds its count until it is read.
- Counter Latch Commands do not affect the programmed Mode of the Counter in any way.
- If a Counter is latched and then, some time later, latched again before the count is read, the second Counter Latch Command is ignored. The count read will be the count at the time the first Counter Latch Command was issued.
- With either method, the count must be read according to the programmed format; specifically, if the Counter is programmed for two byte counts, two bytes must be read. The two bytes do not have to be read one right after the other, read or write or programming operations of other Counters may be inserted between them.
- Another feature of the 8254 is that reads and writes of the same Counter may be interleaved.

- **Example:** If the Counter is programmed for two byte counts, the following sequence is valid.
 - 1) Read least significant byte.
 - 2) Write new least significant byte.
 - 3) Read most significant byte.
 - 4) Write new most significant byte.
- If a Counter is programmed to read/write two-byte counts, the following precaution applies: A program must not transfer control between reading the first and second byte to another routine which also reads from that same Counter. Otherwise, an incorrect count will be read.
- **READ-BACK COMMAND:** The third method uses the Read-Back Command. This command allows the user to check the count value, programmed Mode, and current states of the OUT pin and Null Count flag of the selected counter (s).
- The command is written into the Control Word Register and has the format shown in Figure 10. The command applies to the counters selected by setting their corresponding bits $D_3, D_2, D_1 = 1$.
- The read-back command may be used to latch multiple counter output latches (OL) by setting the COUNT bit $D_5 = 0$ and selecting the desired counter (s). This single command is functionally equivalent to several counter latch commands, one for each counter latched.



- Each counter's latched count is held until it is read (or the counter is reprogrammed).
- The counter is automatically unlatched when read, but other counters remain latched until they are read. If multiple count read-back commands are issued to the same counter without reading the count, all but the first are ignored; i.e., the count which will be read is the count at the time the first read-back command was issued.
- The read-back command may also be used to latch status information of selected counter (s) by setting STATUS bit $D_4 = 0$. Status must be latched to be read; status of a counter is accessed by a read from that counter.
- The counter status format is shown in Figure 11.

- Bits D₅ through D₀ contain the counter's programmed Mode exactly as written in the last Mode Control Word. OUTPUT bit D₇ contains the current state of the OUT pin.
- This allows the user to monitor the counter's output via software, possibly eliminating some hardware from a system. NULL COUNT bit D₆ indicates when the last count written to the counter register (CR) has been loaded into the counting element (CE).
- The exact time this happens depends on the Mode of the counter and is described in the Mode Definitions, but until the count is loaded into the counting element (CE), it can't be read from the counter.

D ₇	D ₆	D ₅	D ₄	D ₃	D ₂	D ₁	D ₀
Output	Null Count	RW1	RW0	M2	M1	M0	BCD
D ₇	1 = OUT Pin is 1 0 = OUT Pin is 0						
D ₆	1 = Null Count 0 = Count available for reading						
D ₅ -D ₀	Counter programmed mode (see Figure 7)						

Figure 11. Status Byte

- If the count is latched or read before this time, the count value will not reflect the new count just written. The operation of Null Count is shown in Figure 12.
- If multiple status latch operations of the counter (s) are performed without reading the status, all but the first are ignored; i.e., the status that will be read is the status of the counter at the time the first status read-back command was issued.
- Both count and status of the selected counter (s) may be latched simultaneously by setting both COUNT and STATUS bits D₅,D₄ = 0. This is functionally the same as issuing two separate read-back commands at once, and the above discussions apply here also.

This Action	Causes
A. Write to the control word register; ⁽¹⁾	Null Count = 1
B. Write to the count register (CR); ⁽²⁾	Null Count = 1
C. New Count is loaded into CE (CR → CE);	Null Count = 0

NOTE:

1. Only the counter specified by the control word will have its Null Count set to 1. Null count bits of other counters are unaffected.
2. If the counter is programmed for two-byte counts (least significant byte then most significant byte) Null Count goes to 1 when the second byte is written.

Figure 12. Null Count Operation

- Specifically, if multiple count and/or status read-back commands are issued to the same counter (s) without any intervening reads, all but the first are ignored. This is illustrated in Figure 13.
- If both count and status of a counter are latched, the first read operation of that counter will return latched status, regardless of which was latched first. The next one or two reads (depending on whether the counter is programmed for one or two type counts) return latched count. Subsequent reads return unlatched count.

Command								Description	Result
D ₇	D ₆	D ₅	D ₄	D ₃	D ₂	D ₁	D ₀		
1	1	0	0	0	0	1	0	Read back count and status of Counter 0	Count and status latched for Counter 0
1	1	1	0	0	1	0	0	Read back status of Counter 1	Status latched for Counter 1
1	1	1	0	1	1	0	0	Read back status of Counters 2, 1	Status latched for Counter 2, but not Counter 1
1	1	0	1	1	0	0	0	Read back count of Counter 2	Count latched for Counter 2
1	1	0	0	0	1	0	0	Read back count and status of Counter 1	Count latched for Counter 1, but not status
1	1	1	0	0	0	1	0	Read back status of Counter 1	Command ignored, status already latched for Counter 1

Figure 13. Read-Back Command Example

\overline{CS}	\overline{RD}	\overline{WR}	A ₁	A ₀	
0	1	0	0	0	Write into Counter 0
0	1	0	0	1	Write into Counter 1
0	1	0	1	0	Write into Counter 2
0	1	0	1	1	Write Control Word
0	0	1	0	0	Read from Counter 0
0	0	1	0	1	Read from Counter 1
0	0	1	1	0	Read from Counter 2
0	0	1	1	1	No-Operation (3-State)
1	X	X	X	X	No-Operation (3-State)
0	1	1	X	X	No-Operation (3-State)

Figure 14. Read/Write Operations Summary

- **Mode Definitions** :The following are defined for use in describing the operation of the 8254.
- **CLK Pulse**: A rising edge, then a falling edge, in that order, of a Counter's CLK input.
- **Trigger**: A rising edge of a Counter's GATE input.

- **Counter loading:** The transfer of a count from the CR to the CE (refer to the "Functional Description").
- **MODE 0: INTERRUPT ON TERMINAL COUNT :**
- Mode 0 is typically used for event counting. After the Control Word is written, OUT is initially low, and will remain low until the Counter reaches zero.
- OUT then goes high and remains high until a new count or a new Mode 0 Control Word is written into the Counter.
- GATE = 1 enables counting; GATE = 0 disables counting. GATE has no effect on OUT.
- After the Control Word and initial count are written to a Counter, the initial count will be loaded on the next CLK pulse. This CLK pulse does not decrement the count, so for an initial count of N, OUT does not go high until N + 1 CLK pulses after the initial count is written.
- If a new count is written to the Counter, it will be loaded on the next CLK pulse and counting will continue from the new count. If a two-byte count is written, the following happens:
 - 1) Writing the first byte disables counting. OUT is set low immediately (no clock pulse required).
 - 2) Writing the second byte allows the new count to be loaded on the next CLK pulse.
 - This allows the counting sequence to be synchronized by software. Again, OUT does not go high until N + 1 CLK pulses after the new count of N is written.
 - If an initial count is written while GATE = 0, it will still be loaded on the next CLK pulse. When GATE goes high, OUT will go high N CLK pulses later; no CLK pulse is needed to load the Counter as this has already been done.

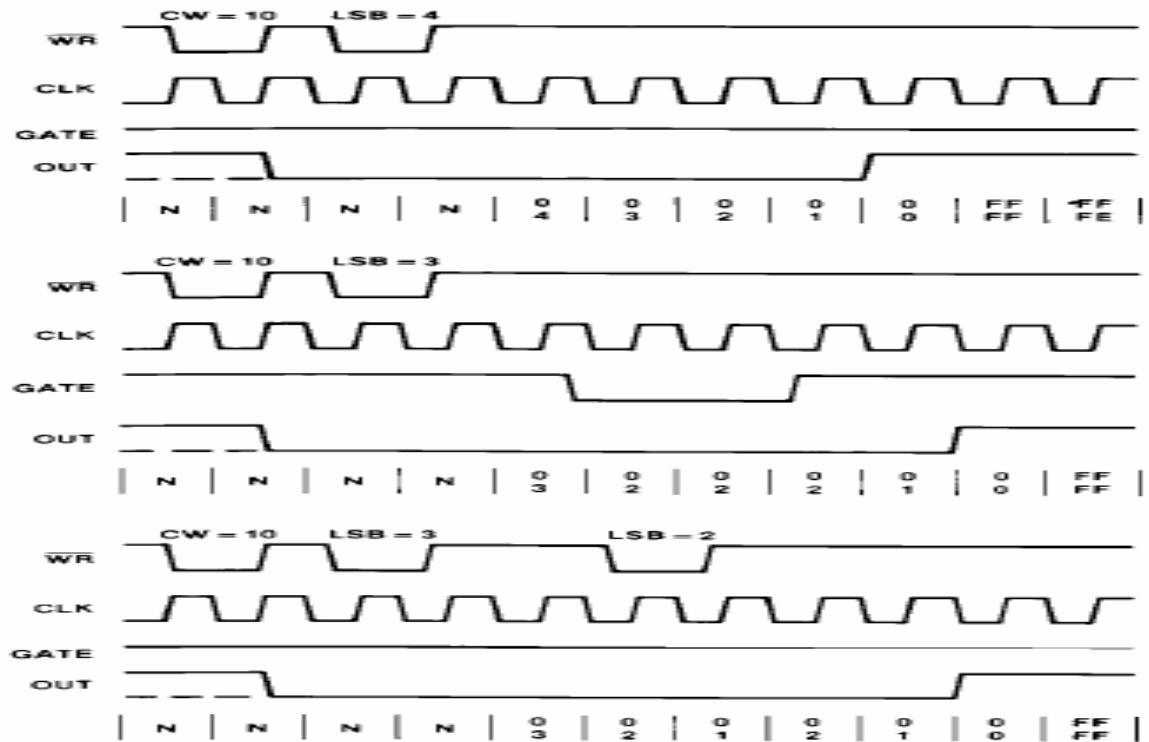

Figure 15. Mode 0

Note:

1. Counters are programmed for binary (not BCD) counting and for reading/writing least significant byte (LSB) only.
2. The counter is always selected (CS always low).
3. CW stands for "Control Word"; CW = 10 means a control word of 10 HEX is written to the counter.
4. LSB stands for "Least Significant Byte" of count.
5. Numbers below diagrams are count values. The lower number is the least significant byte. The upper number is the most significant byte. Since the counter is programmed to read/write LSB only, the most significant byte cannot be read. N stands for an undefined count. Vertical lines show transitions between count values.

- **MODE 1: *HARDWARE RETRIGGERABLE ONE-SHOT*:** OUT will be initially high.
- OUT will go low on the CLK pulse following a trigger to begin the one-shot pulse, and will remain low until the Counter reaches zero.
- OUT will then go high and remain high until the CLK pulse after the next trigger.
- After writing the Control Word and initial count, the Counter is armed. A trigger results in loading the Counter and setting OUT low on the next CLK pulse, thus starting the one-shot pulse. An initial count of N will result in a one-shot pulse N CLK cycles in duration.

- The one-shot is retriggerable, hence OUT will remain low for N CLK pulses after any trigger. The one-shot pulse can be repeated without rewriting the same count into the counter. GATE has no effect on OUT.
- If a new count is written to the Counter during a oneshot pulse, the current one-shot is not affected unless the counter is retriggered. In that case, the Counter is loaded with the new count and the oneshot pulse continues until the new count expires.

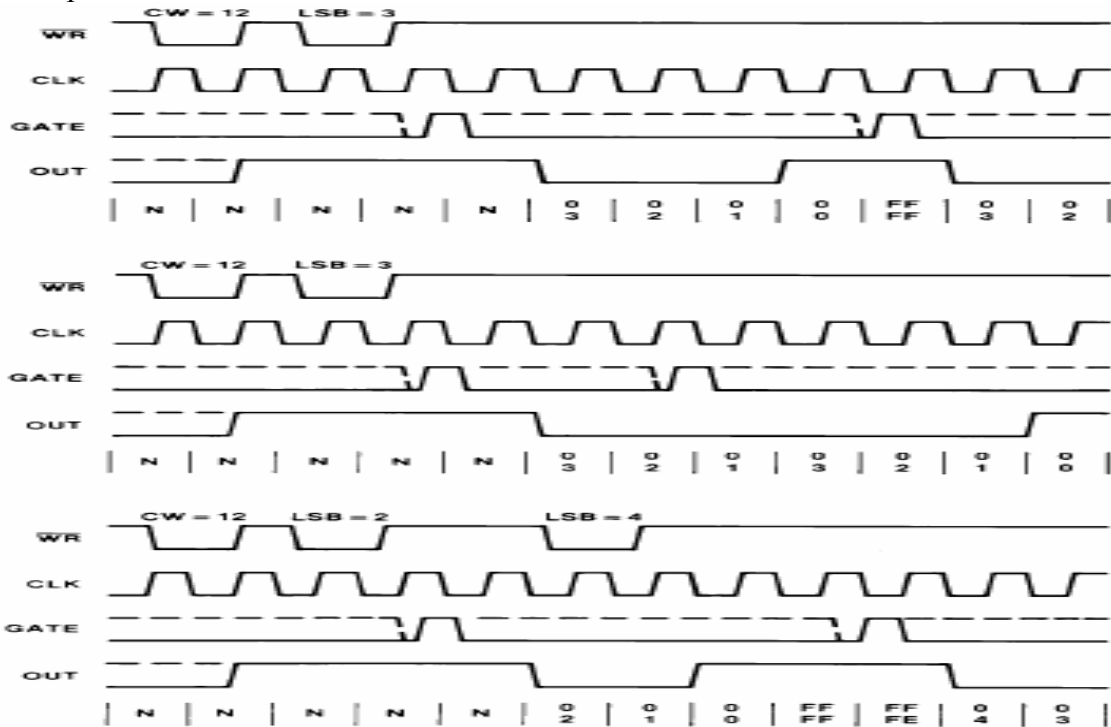

Figure 16. Mode 1

- **MODE 2: RATE GENERATOR:** This Mode functions like a divide-by-N counter. It is typically used to generate a Real Time Clock interrupt.
- OUT will initially be high. When the initial count has decremented to 1, OUT goes low for one CLK pulse. OUT then goes high again, the Counter reloads the initial count and the process is repeated.
- Mode 2 is periodic, the same sequence is repeated indefinitely. For an initial count of N, the sequence repeats every N CLK cycles.
- GATE = 1 enables counting; GATE = 0 disables counting. If GATE goes low during an output pulse, OUT is set high immediately.
- A trigger reloads the Counter with the initial count on the next CLK pulse, OUT goes low N CLK pulses after the trigger. Thus the GATE input can be used to synchronize the Counter.
- After writing a Control Word and initial count, the Counter will be loaded on the next CLK pulse. OUT goes low N CLK Pulses after the initial count is written.
- This allows the Counter to be synchronized by software also. Writing a new count while counting does not affect the current counting sequence.

- If a trigger is received after writing a new count but before the end of the current period, the Counter will be loaded with the new count on the next CLK pulse and counting will continue from the new count.
- Otherwise, the new count will be loaded at the end of the current counting cycle. In mode 2, a COUNT of 1 is illegal.
- **MODE 3: SQUARE WAVE MODE** : Mode 3 is typically used for Baud rate generation. Mode 3 is similar to Mode 2 except for the duty cycle of OUT. OUT will initially be high.

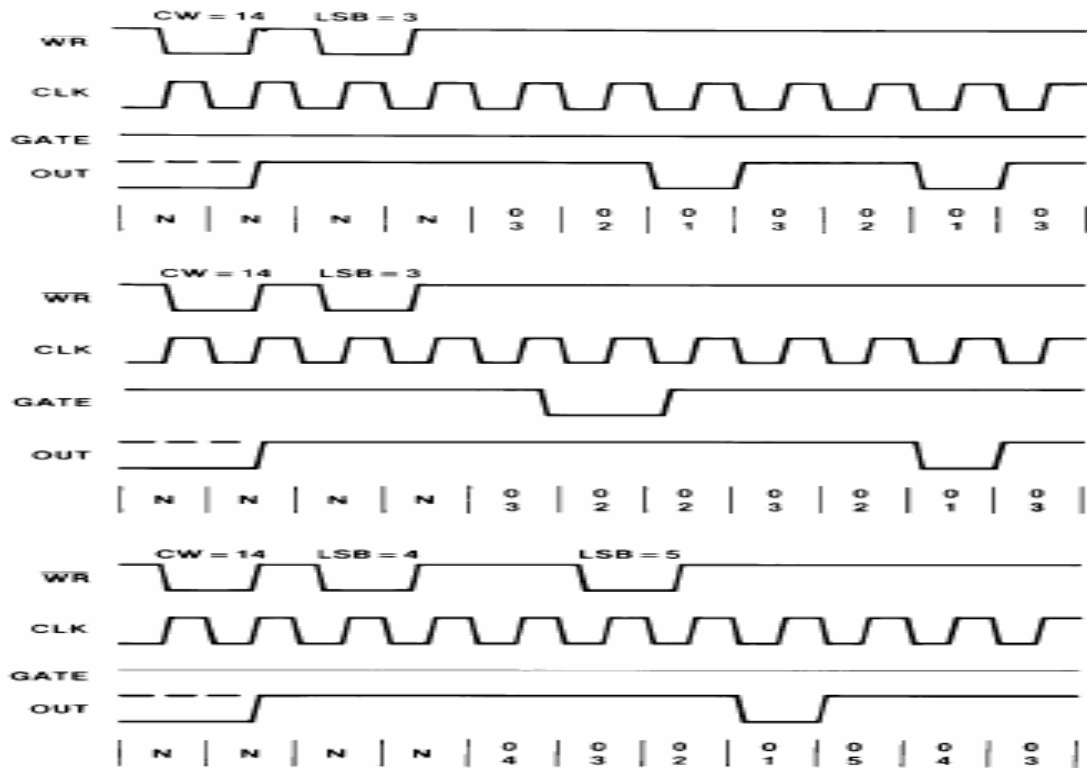

Figure 17. Mode 2

- When half the initial count has expired, OUT goes low for the remainder of the count. Mode 3 is periodic; the sequence above is repeated indefinitely.
- An initial count of N results in a square wave with a period of N CLK cycles. GATE = 1 enables counting; GATE = 0 disables counting. If GATE goes low while OUT is low, OUT is set high immediately; no CLK pulse is required.
- A trigger reloads the Counter with the initial count on the next CLK pulse. Thus the GATE input can be used to synchronize the Counter.
- After writing a Control Word and initial count, the Counter will be loaded on the next CLK pulse. This allows the Counter to be synchronized by software also.
- Writing a new count while counting does not affect the current counting sequence. If a trigger is received after writing a new count but before the end of the current half-cycle of the square wave, the Counter will be loaded with the new count on the next CLK pulse and counting will continue from the new count. Otherwise, the new count will be loaded at the end of the current half-cycle.

- **Mode 3: Even counts:** OUT is initially high. The initial count is loaded on one CLK pulse and then is decremented by two on succeeding CLK pulses.
- When the count expires OUT changes value and the Counter is reloaded with the initial count. The above process is repeated indefinitely.
- **Odd counts:** OUT is initially high. The initial count minus one (an even number) is loaded on one CLK pulse and then is decremented by two on succeeding CLK pulses.

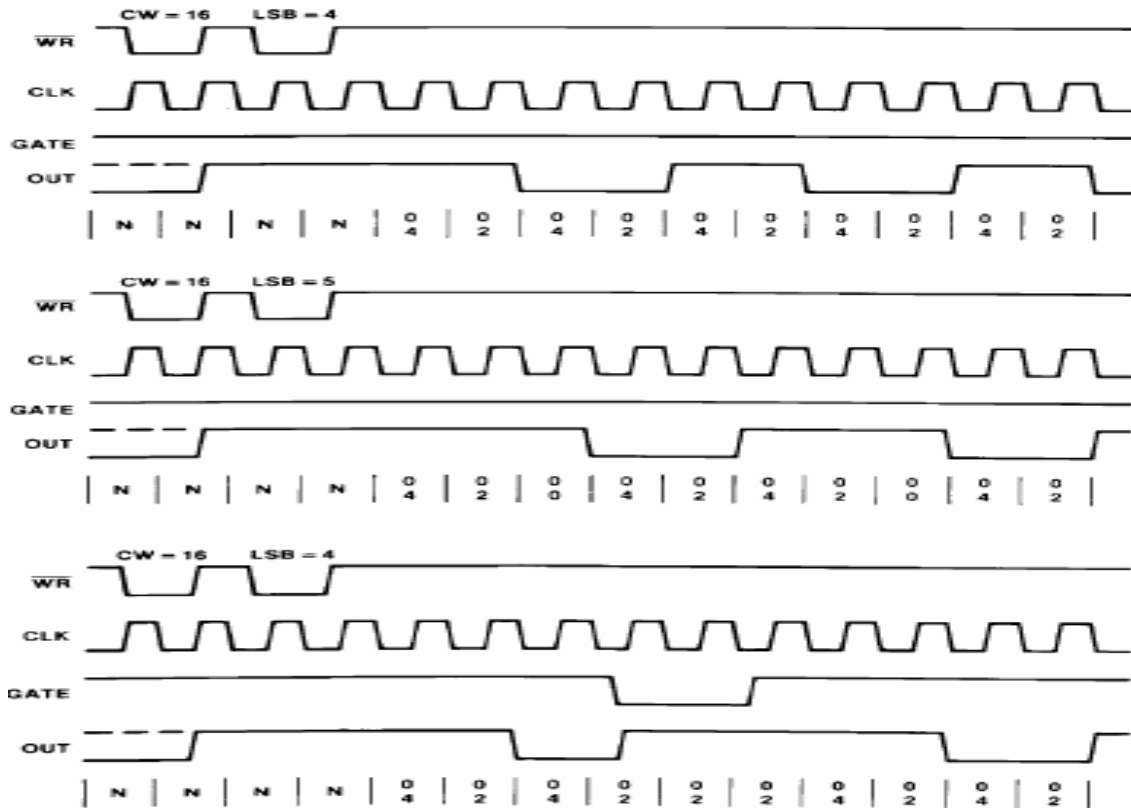

Figure 18. Mode 3

- One CLK pulse after the count expires, OUT goes low and the Counter is reloaded with the initial count minus one.
- Succeeding CLK pulses decrement the count by two.
- When the count expires, OUT goes high again and the Counter is reloaded with the initial count minus one. The above process is repeated indefinitely.
- So for odd counts, OUT will be high for $(N - 1)/2$ counts and low for $(N - 1)/2$ counts.
- **MODE 4: SOFTWARE TRIGGERED STROBE :**
- OUT will be initially high. When the initial count expires, OUT will go low for one CLK pulse and then go high again. The counting sequence is ``triggered`` by writing the initial count.
- GATE = 1 enables counting; GATE = 0 disables counting. GATE has no effect on OUT. After writing a Control Word and initial count, the Counter will be loaded on the next CLK pulse.

- This CLK pulse does not decrement the count, so for an initial count of N, OUT does not strobe low until N + 1 CLK pulses after the initial count is written.
- If a new count is written during counting, it will be loaded on the next CLK pulse and counting will continue from the new count. If a two-byte count is written, the following happens:
 - 1) Writing the first byte has no effect on counting.
 - 2) Writing the second byte allows the new count to be loaded on the next CLK pulse.
- This allows the sequence to be "retriggered" by software. OUT strobes low N + 1 CLK pulses after the new count of N is written.

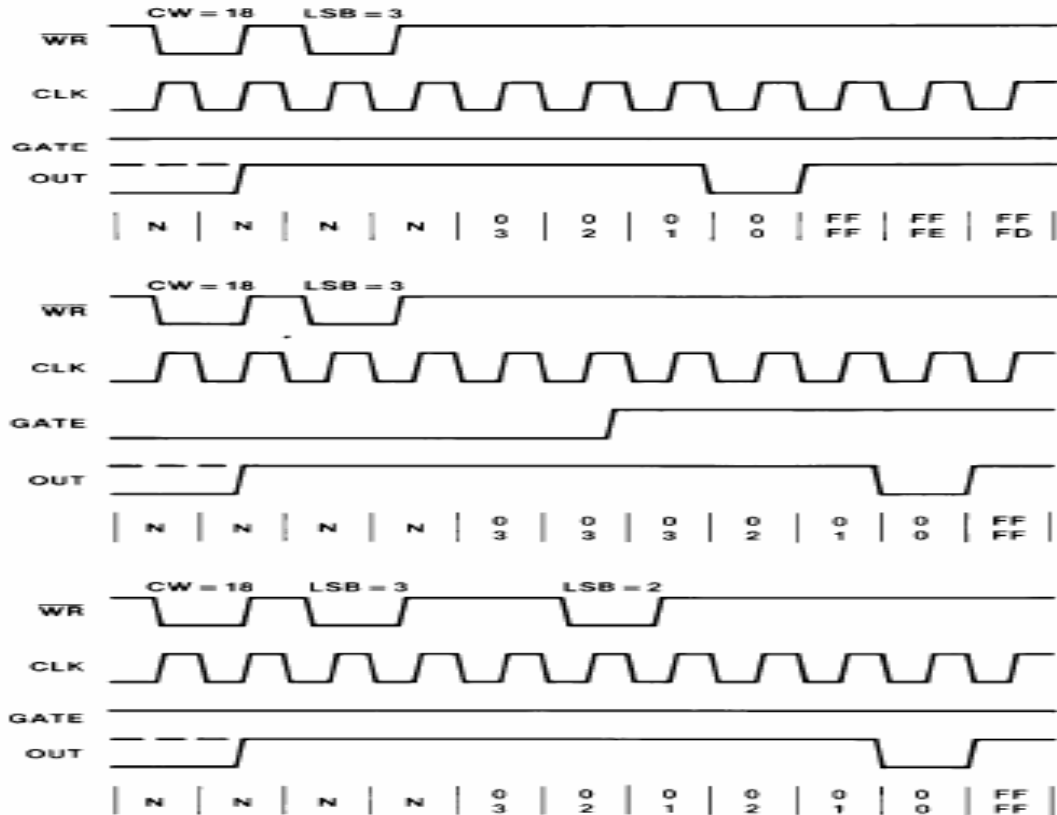

Figure 19. Mode 4

- **MODE 5: HARDWARE TRIGGERED STROBE (RETRIGGERABLE):** OUT will initially be high. Counting is triggered by a rising edge of GATE. When the initial count has expired, OUT will go low for one CLK pulse and then go high again.
- After writing the Control Word and initial count, the counter will not be loaded until the CLK pulse after a trigger. This CLK pulse does not decrement the count, so for an initial count of N, OUT does not strobe low until N = 1 CLK pulses after a trigger.
- A trigger results in the Counter being loaded with the initial count on the next CLK pulse. The counting sequence is retriggerable. OUT will not strobe low for N + 1 CLK pulses after any trigger. GATE has no effect on OUT.
- If a new count is written during counting, the current counting sequence will not be affected. If a trigger occurs after the new count is written but before the current

count expires, the Counter will be loaded with the new count on the next CLK pulse and counting will continue from there.

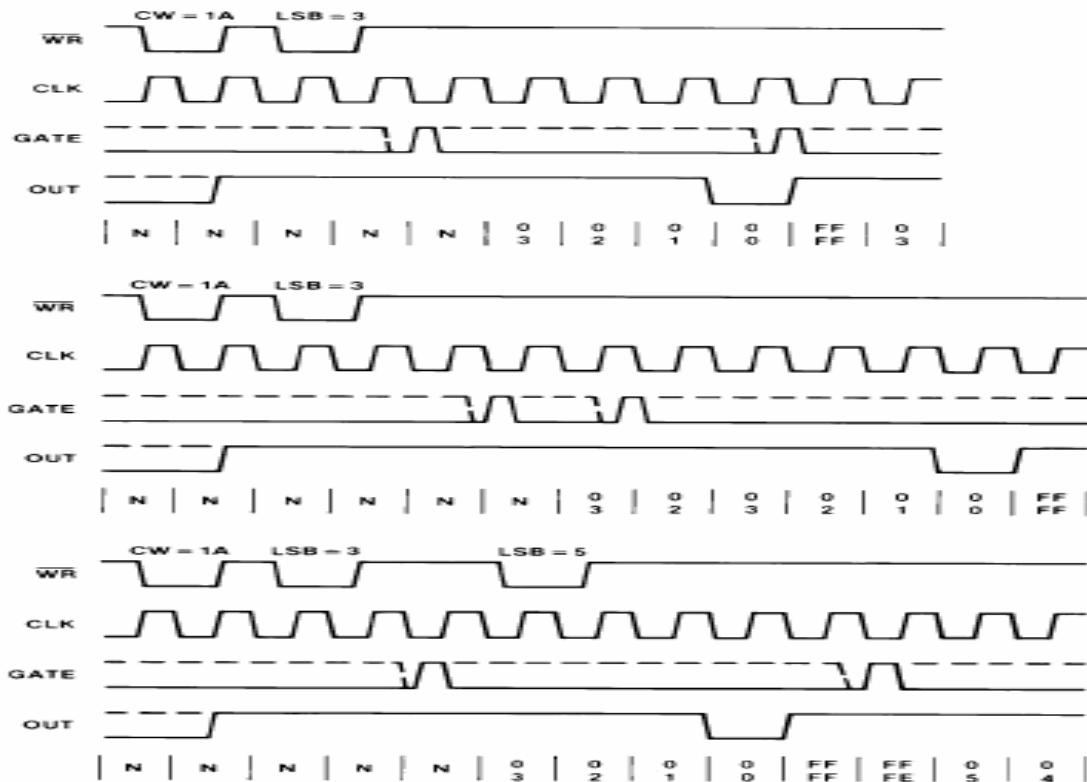

Figure 20. Mode 5

- **Operation Common to All Modes:**
- **PROGRAMMING:** When a Control Word is written to a Counter, all Control Logic is immediately reset and OUT goes to a known initial state; no CLK pulses are required for this.
- **GATE:** The GATE input is always sampled on the rising edge of CLK. In Modes 0, 2, 3, and 4 the GATE input is level sensitive, and the logic level is sampled on the rising edge of CLK. In Modes 1, 2, 3, and 5 the GATE input is rising-edge sensitive.
- In these Modes, a rising edge of GATE (trigger) sets an edge-sensitive flip-flop in the Counter. This flip-flop is then sampled on the next rising edge of CLK; the flip-flop is reset immediately after it is sampled. In this way, a trigger will be detected no matter when it occurs—a high logic level does not have to be maintained until the next rising edge of CLK.
- Note that in Modes 2 and 3, the GATE input is both edge- and level-sensitive. In Modes 2 and 3, if a CLK source other than the system clock is used, GATE should be pulsed immediately following WR of a new count value.

Signal Status Modes	Low Or Going Low	Rising	High
0	Disables Counting	— —	Enables Counting
1	— —	1) Initiates Counting 2) Resets Output after Next Clock	— —
2	1) Disables Counting 2) Sets Output Immediately High	Initiates Counting	Enables Counting
3	1) Disables Counting 2) Sets Output Immediately High	Initiates Counting	Enables Counting
4	Disables Counting	— —	Enables Counting
5	— —	Initiates Counting	— —

Figure 21. Gate Pin Operations Summary

- **COUNTER:** New counts are loaded and Counters are decremented on the falling edge of CLK.
- The largest possible initial count is 0, this is equivalent to 216 for binary counting and 104 for BCD counting. The Counter does not stop when it reaches zero.
- In Modes 0, 1, 4, and 5 the Counter ``wraps around" to the highest count, either FFFF hex for binary counting or 9999 for BCD counting, and continues counting.
- Modes 2 and 3 are periodic; the Counter reloads itself with the initial count and continues counting from there.

Mode	Min Count	Max Count
0	1	0
1	1	0
2	2	0
3	2	0
4	1	0
5	1	0

NOTE: 0 is equivalent to 2^{16} for binary counting and 10^4 for BCD counting.

Figure 22. Minimum and Maximum Initial Counts

8279

- While studying 8255, we have explained the use of 8255 in interfacing keyboards and displays with 8086. The disadvantages of this method of interfacing keyboard and display with 8086 is that the processor has to refresh the display and check the status of the keyboard periodically using polling technique. Thus a considerable amount of CPU time is wasted, reducing the system operating speed.
- Intel's 8279 is a general purpose keyboard display controller that simultaneously drives the display of a system and interfaces a keyboard with the CPU, leaving it free for its routine task.

Architecture and Signal Descriptions of 8279

- The keyboard display controller chip 8279 provides:
 - a) a set of four scan lines and eight return lines for interfacing keyboards
 - b) A set of eight output lines for interfacing display.
- Fig shows the functional block diagram of 8279 followed by its brief description.
- **I/O Control and Data Buffers** : The I/O control section controls the flow of data to/from the 8279. The data buffers interface the external bus of the system with internal bus of 8279.
- The I/O section is enabled only if CS is low. The pins A0, RD and WR select the command, status or data read/write operations carried out by the CPU with 8279.
- **Control and Timing Register and Timing Control** : These registers store the keyboard and display modes and other operating conditions programmed by CPU. The registers are written with A0=1 and WR=0. The Timing and control unit controls the basic timings for the operation of the circuit. Scan counter divide down the operating frequency of 8279 to derive scan keyboard and scan display frequencies.
- **Scan Counter** : The scan counter has two modes to scan the key matrix and refresh the display. In the encoded mode, the counter provides binary count that is to be externally decoded to provide the scan lines for keyboard and display (Four

externally decoded scan lines may drive upto 16 displays). In the decode scan mode, the counter internally decodes the least significant 2 bits and provides a decoded 1 out of 4 scan on SL0-SL3(Four internally decoded scan lines may drive upto 4 displays). The keyboard and display both are in the same mode at a time.

- **Return Buffers and Keyboard Debounce and Control:** This section for a key closure row wise. If a key closer is detected, the keyboard debounce unit debounces the key entry (i.e. wait for 10 ms). After the debounce period, if the key continues to be detected. The code of key is directly transferred to the sensor RAM along with SHIFT and CONTROL key status.
- **FIFO/Sensor RAM and Status Logic:** In keyboard or strobed input mode, this block acts as 8-byte first-in-first-out (FIFO) RAM. Each key code of the pressed key is entered in the order of the entry and in the mean time read by the CPU, till the RAM become empty.
- The status logic generates an interrupt after each FIFO read operation till the FIFO is empty. In scanned sensor matrix mode, this unit acts as sensor RAM. Each row of the sensor RAM is loaded with the status of the corresponding row of sensors in the matrix. If a sensor changes its state, the IRQ line goes high to interrupt the CPU.
- **Display Address Registers and Display RAM :** The display address register holds the address of the word currently being written or read by the CPU to or from the display RAM. The contents of the registers are automatically updated by 8279 to accept the next data entry by CPU.

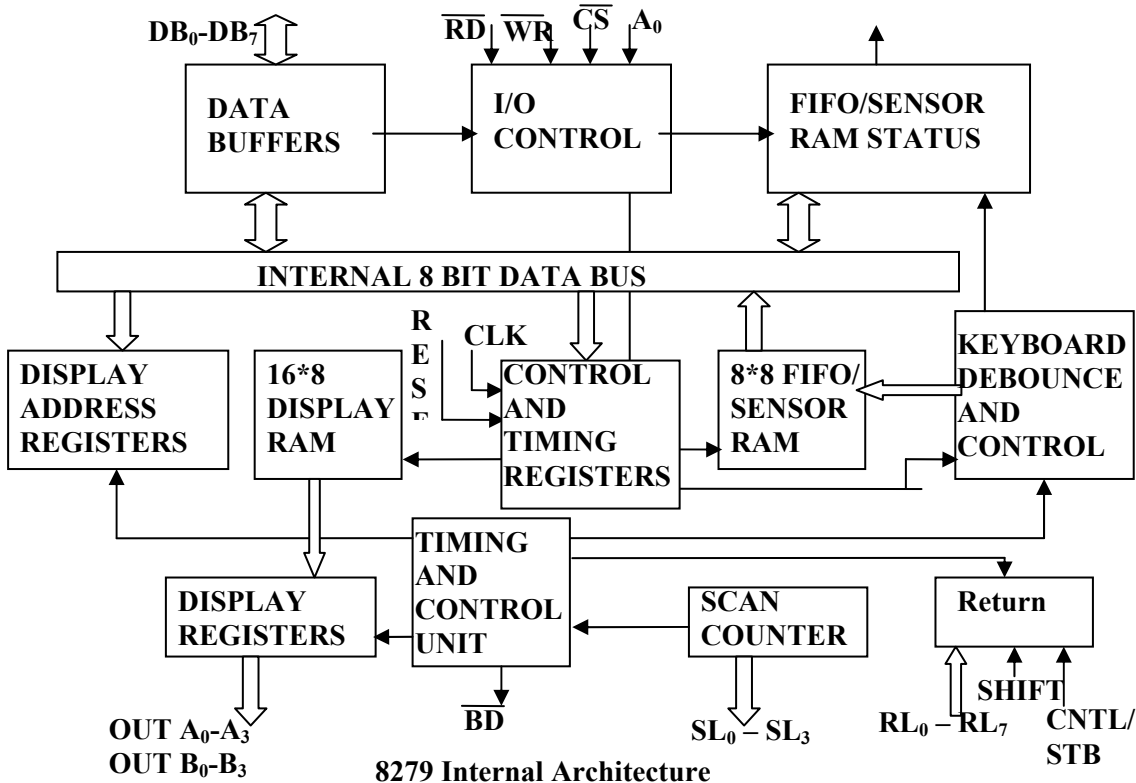

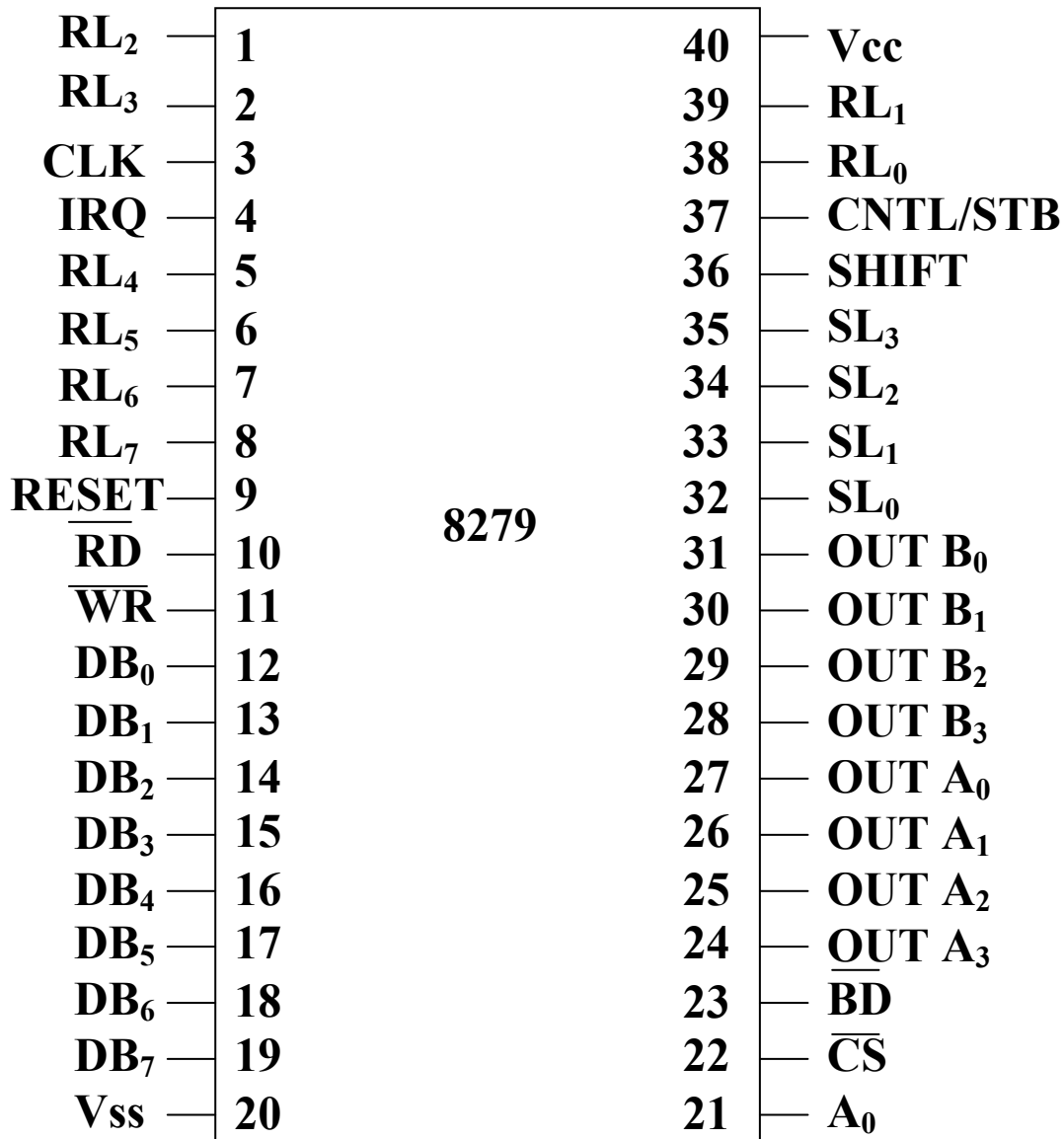

8279 Pin Configuration

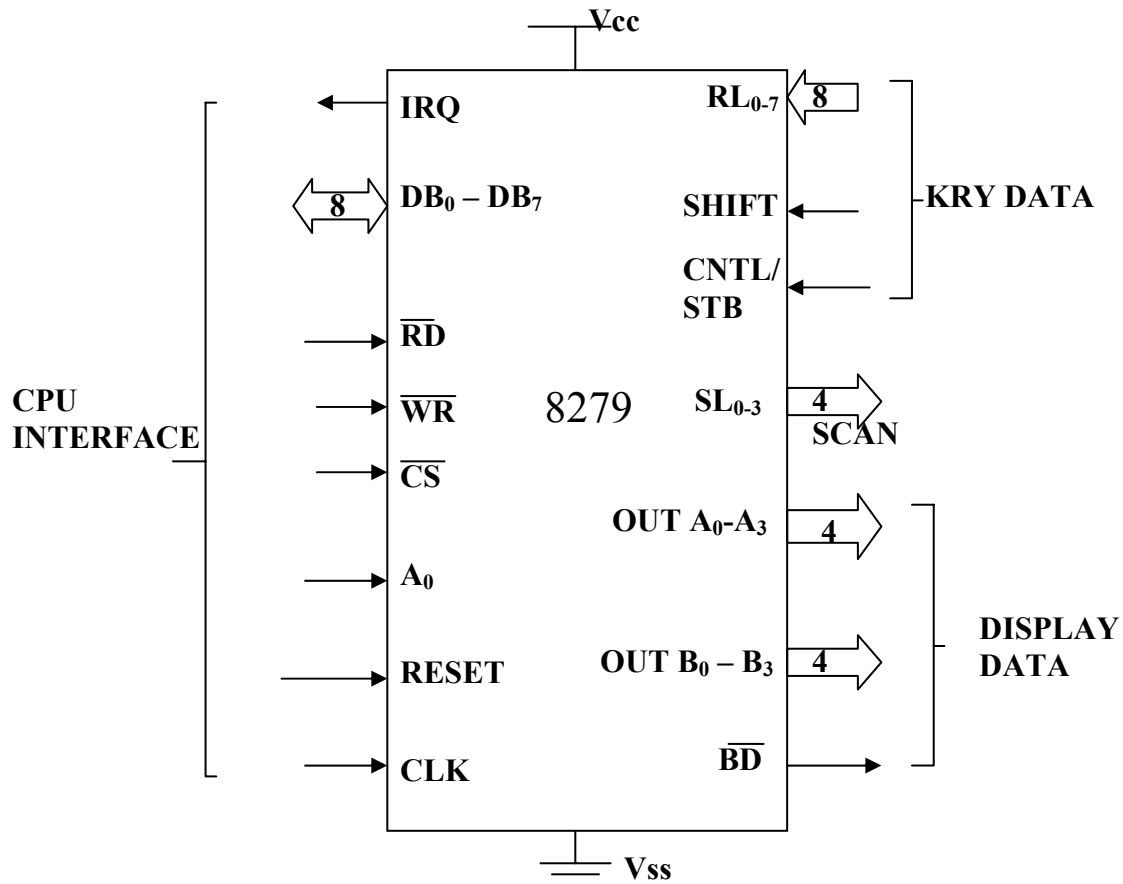

- The signal description of each of the pins of 8279 as follows :
- **DB0-DB7** : These are bidirectional data bus lines. The data and command words to and from the CPU are transferred on these lines.
- **CLK** : This is a clock input used to generate internal timing required by 8279.
- **RESET** : This pin is used to reset 8279. A high on this line reset 8279. After resetting 8279, its in sixteen 8-bit display, left entry encoded scan, 2-key lock out mode. The clock prescaler is set to 31.
- **CS** : Chip Select – A low on this line enables 8279 for normal read or write operations. Other wise, this pin should remain high.
- **A₀** : A high on this line indicates the transfer of a command or status information. A low on this line indicates the transfer of data. This is used to select one of the internal registers of 8279.
- **RD, WR (Input/Output) READ/WRITE** – These input pins enable the data buffers to receive or send data over the data bus.
- **IRQ** : This interrupt output lines goes high when there is a data in the FIFO sensor RAM. The interrupt lines goes low with each FIFO RAM read operation but if the FIFO RAM further contains any key-code entry to be read by the CPU, this pin again goes high to generate an interrupt to the CPU.
- **Vss, Vcc** : These are the ground and power supply lines for the circuit.
- **SL0-SL3-Scan Lines** : These lines are used to scan the key board matrix and display digits. These lines can be programmed as encoded or decoded, using the mode control register.

- **RL₀ - RL₇ - Return Lines** : These are the input lines which are connected to one terminal of keys, while the other terminal of the keys are connected to the decoded scan lines. These are normally high, but pulled low when a key is pressed.
- **SHIFT** : The status of the shift input lines is stored along with each key code in FIFO, in scanned keyboard mode. It is pulled up internally to keep it high, till it is pulled low with a key closure.
- **BD – Blank Display** : This output pin is used to blank the display during digit switching or by a blanking closure.
- **OUT A₀ – OUT A₃ and OUT B₀ – OUT B₃** – These are the output ports for two 16*4 or 16*8 internal display refresh registers. The data from these lines is synchronized with the scan lines to scan the display and keyboard. The two 4-bit ports may also as one 8-bit port.
- **CNTL/STB- CONTROL/STROBED I/P Mode** : In keyboard mode, this lines is used as a control input and stored in FIFO on a key closure. The line is a strobed lines that enters the data into FIFO RAM, in strobed input mode. It has an interrupt pull up. The lines is pulled down with a key closer.

Modes of Operation of 8279

- The modes of operation of 8279 are as follows :
 1. Input (Keyboard) modes.
 2. Output (Display) modes.
- **Input (Keyboard) Modes** : 8279 provides three input modes. These modes are as follows:
 1. **Scanned Keyboard Mode** : This mode allows a key matrix to be interfaced using either encoded or decoded scans. In encoded scan, an 8*8 keyboard or in decoded scan, a 4*8 keyboard can be interfaced. The code of key pressed with SHIFT and CONTROL status is stored into the FIFO RAM.
 2. **Scanned Sensor Matrix** : In this mode, a sensor array can be interfaced with 8279 using either encoded or decoded scans. With encoded scan 8*8 sensor matrix or with decoded scan 4*8 sensor matrix can be interfaced. The sensor codes are stored in the CPU addressable sensor RAM.
 3. **Strobed input**: In this mode, if the control lines goes low, the data on return lines, is stored in the FIFO byte by byte.
- **Output (Display) Modes** : 8279 provides two output modes for selecting the display options. These are discussed briefly.
 1. **Display Scan** : In this mode 8279 provides 8 or 16 character multiplexed displays those can be organized as dual 4- bit or single 8-bit display units.
 2. **Display Entry** : (right entry or left entry mode) 8279 allows options for data entry on the displays. The display data is entered for display either from the right side or from the left side.

Keyboard Modes

- i. **Scanned Keyboard mode with 2 Key Lockout** : In this mode of operation, when a key is pressed, a debounce logic comes into operation. During the next two scans, other keys are checked for closure and if no other key is pressed the first pressed key is identified.

- The key code of the identified key is entered into the FIFO with SHIFT and CNTL status, provided the FIFO is not full, i.e. it has at least one byte free. If the FIFO does not have any free byte, naturally the key data will not be entered and the error flag is set.
 - If FIFO has at least one byte free, the above code is entered into it and the 8279 generates an interrupt on IRQ line to the CPU to inform about the previous key closures. If another key is found closed during the first key, the keycode is entered in FIFO.
 - If the first pressed key is released before the others, the first will be ignored. A key code is entered to FIFO only once for each valid depression, independent of other keys pressed along with it, or released before it.
 - If two keys are pressed within a debounce cycle (simultaneously), no key is recognized till one of them remains closed and the other is released. The last key, that remains depressed is considered as single valid key depression.
- ii. **Scanned Keyboard with N-Key Rollover** : In this mode, each key depression is treated independently. When a key is pressed, the debounce circuit waits for 2 keyboards scans and then checks whether the key is still depressed. If it is still depressed, the code is entered in FIFO RAM.
- Any number of keys can be pressed simultaneously and recognized in the order, the keyboard scan recorded them. All the codes of such keys are entered into FIFO.
- In this mode, the first pressed key need not be released before the second is pressed. All the keys are sensed in the order of their depression, rather in the order the keyboard scan senses them, and independent of the order of their release.
- iii. **Scanned Keyboard Special Error Mode** : This mode is valid only under the N-Key rollover mode. This mode is programmed using end interrupt / error mode set command. If during a single debounce period (two keyboard scans) two keys are found pressed , this is considered a simultaneous depression and an error flag is set.
- This flag, if set, prevents further writing in FIFO but allows the generation of further interrupts to the CPU for FIFO read. The error flag can be read by reading the FIFO status word. The error Flag is set by sending normal clear command with CF = 1.
- iv. **Sensor Matrix Mode** : In the sensor matrix mode, the debounce logic is inhibited. The 8-byte FIFO RAM now acts as 8 * 8 bit memory matrix. The status of the sensor switch matrix is fed directly to sensor RAM matrix. Thus the sensor RAM bits contains the row-wise and column wise status of the sensors in the sensor matrix.
- The IRQ line goes high, if any change in sensor value is detected at the end of a sensor matrix scan or the sensor RAM has a previous entry to be read by the CPU. The IRQ line is reset by the first data read operation, if AI = 0, otherwise, by issuing the end interrupt command. AI is a bit in read sensor RAM word.

Display Modes

- There are various options of data display. For example, the command number of characters can be 8 or 16, with each character organised as single 8-bit or dual 4-bit codes. Similarly there are two display formats.
 - The first one is known as left entry mode or type writer mode, since in a type writer the first character typed appears at the left-most position, while the subsequent characters appear successively to the right of the first one. The other display format is known as right entry mode, or calculator mode, since in a calculator the first character entered appears at the rightmost position and this character is shifted one position left when the next characters is entered.
 - Thus all the previously entered characters are shifted left by one position when a new characters is entered.
- i. **Left Entry Mode** : In the left entry mode, the data is entered from left side of the display unit. Address 0 of the display RAM contains the leftmost display characters and address 15 of the RAM contains the right most display characters. It is just like writing in our address is automatically updated with successive reads or writes. The first entry is displayed on the leftmost display and the sixteenth entry on the rightmost display. The seventeenth entry is again displayed at the leftmost display position.
 - ii. **Right Entry Mode** : In this right entry mode, the first entry to be displayed is entered on the rightmost display. The next entry is also placed in the right most display but after the previous display is shifted left by one display position. The leftmost characters is shifted out of that display at the seventeenth entry and is lost, i.e. it is pushed out of the display RAM.

Command Words of 8279

- All the command words or status words are written or read with $A_0 = 1$ and $CS = 0$ to or from 8279. This section describes the various command available in 8279.
- a) **Keyboard Display Mode Set** – The format of the command word to select different modes of operation of 8279 is given below with its bit definitions.

D_7	D_6	D_5	D_4	D_3	D_2	D_1	D_0	A_0
0	0	D	D	D	K	K	K	1

D	D	Display modes
0	0	Eight 8-bit character Left entry
0	1	Sixteen 8-bit character left entry
1	0	Eight 8-bit character Right entry
1	1	Sixteen 8-bit character Right entry

K	K	K	Keyboard modes
0	0	0	Encoded Scan, 2 key lockout (Default after reset)
0	0	1	Decoded Scan, 2 key lockout
0	1	0	Encoded Scan, N- key Roll over
0	1	1	Decoded Scan, N- key Roll over
1	0	0	Encode Scan, N- key Roll over
1	0	1	Decoded Scan, N- key Roll over
1	1	0	Strobed Input Encoded Scan
1	1	1	Strobed Input Decoded Scan

- b) **Programmable clock** : The clock for operation of 8279 is obtained by dividing the external clock input signal by a programmable constant called prescaler.
- P P P P P is a 5-bit binary constant. The input frequency is divided by a decimal constant ranging from 2 to 31, decided by the bits of an internal prescaler, P P P P P.

D ₇	D ₆	D ₅	D ₄	D ₃	D ₂	D ₁	D ₀	A ₀
0	0	1	P	P	P	P	P	1

- c) **Read FIFO / Sensor RAM** : The format of this command is given below.
- This word is written to set up 8279 for reading FIFO/ sensor RAM. In scanned keyboard mode, AI and AAA bits are of no use. The 8279 will automatically drive data bus for each subsequent read, in the same sequence, in which the data was entered.
 - In sensor matrix mode, the bits AAA select one of the 8 rows of RAM. If AI flag is set, each successive read will be from the subsequent RAM location.

D ₇	D ₆	D ₅	D ₄	D ₃	D ₂	D ₁	D ₀	A ₀
0	1	0	AI	X	A	A	A	1

X – don't care

AI – Auto Increment Flag

AAA – Address pointer to 8 bit FIFO RAM

- d) **Read Display RAM** : This command enables a programmer to read the display RAM data. The CPU writes this command word to 8279 to prepare it for display RAM read operation. AI is auto increment flag and AAAA, the 4-bit address points to the 16-byte display RAM that is to be read. If AI=1, the address will be automatically, incremented after each read or write to the Display RAM. The same address counter is used for reading and writing.

D ₇	D ₆	D ₅	D ₄	D ₃	D ₂	D ₁	D ₀	A ₀
0	1	1	AI	A	A	A	A	1

- e) **Write Display RAM**:

AI – Auto increment Flag.

AAAA – 4 bit address for 16-bit display RAM to be written.

D ₇	D ₆	D ₅	D ₄	D ₃	D ₂	D ₁	D ₀	A ₀
1	0	0	AI	A	A	A	A	1

- f) **Display Write Inhibit/Blanking** : The IW (inhibit write flag) bits are used to mask the individual nibble as shown in the below command word. The output lines are divided into two nibbles (OUTA0 – OUTA3) and (OUTB0 – OUTB3), those can be masked by setting the corresponding IW bit to 1.
- Once a nibble is masked by setting the corresponding IW bit to 1, the entry to display RAM does not affect the nibble even though it may change the unmasked nibble. The blank display bit flags (BL) are used for blanking A and B nibbles.
 - Here D₀, D₂ corresponds to OUTB0 – OUTB3 while D₁ and D₃ corresponds to OUTA0-OUTA3 for blanking and masking.
 - If the user wants to clear the display, blank (BL) bits are available for each nibble as shown in format. Both BL bits will have to be cleared for blanking both the nibbles.

D ₇	D ₆	D ₅	D ₄	D ₃	D ₂	D ₁	D ₀	A ₀
1	0	1	X	IW	IW	BL	BL	1

- g) **Clear Display RAM** : The CD2, CD1, CD0 is a selectable blanking code to clear all the rows of the display RAM as given below. The characters A and B represents the output nibbles.
- CD2 must be 1 for enabling the clear display command. If CD2 = 0, the clear display command is invoked by setting CA=1 and maintaining CD1, CD0 bits exactly same as above. If CF=1, FIFO status is cleared and IRQ line is pulled down.
 - Also the sensor RAM pointer is set to row 0. if CA=1, this combines the effect of CD and CF bits. Here, CA represents Clear All and CF as Clear FIFO RAM.

D ₇	D ₆	D ₅	D ₄	D ₃	D ₂	D ₁	D ₀	A ₀
1	1	0	CD ₂	CD ₁	CD ₀	CF	CA	1

CD ₂	CD ₁	CD ₀
1	0	X
1	1	0
1	1	1

All zeros (x don't care) AB=00

A3-A0 =2 (0010) and B3-B0=00 (0000)

All ones (AB =FF), i.e. clear RAM

- h) **End Interrupt / Error mode Set** : For the sensor matrix mode, this command lowers the IRQ line and enables further writing into the RAM. Otherwise, if a change in sensor value is detected, IRQ goes high that inhibits writing in the sensor RAM.
- For N-Key roll over mode, if the E bit is programmed to be '1', the 8279 operates in special Error mode. Details of this mode are described in scanned keyboard special error mode. X- don't care.

D ₇	D ₆	D ₅	D ₄	D ₃	D ₂	D ₁	D ₀	A ₀
1	1	1	E	X	X	X	X	1

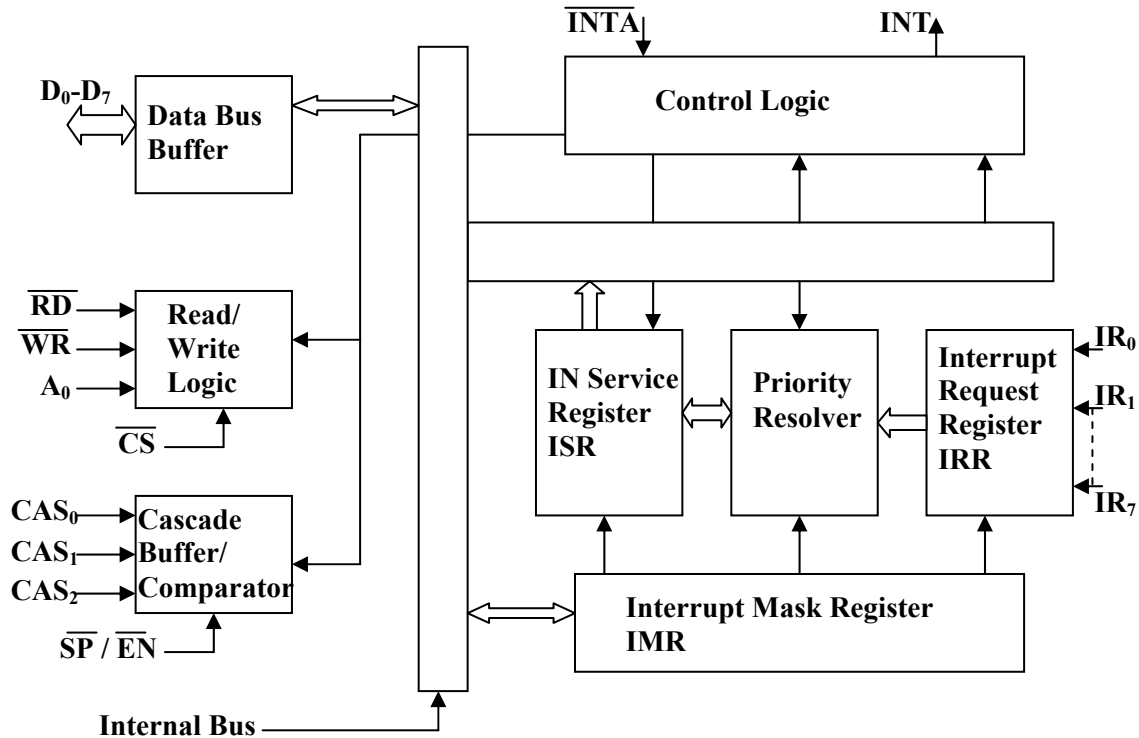

Fig:1 8259A Block Diagram

- **Priority Resolver** : This unit determines the priorities of the interrupt requests appearing simultaneously. The highest priority is selected and stored into the corresponding bit of ISR during INTA pulse. The IR₀ has the highest priority while the IR₇ has the lowest one, normally in fixed priority mode. The priorities however may be altered by programming the 8259A in rotating priority mode.
- **Interrupt Mask Register (IMR)** : This register stores the bits required to mask the interrupt inputs. IMR operates on IRR at the direction of the Priority Resolver.
- **Interrupt Control Logic**: This block manages the interrupt and interrupt acknowledge signals to be sent to the CPU for serving one of the eight interrupt requests. This also accepts the interrupt acknowledge (INTA) signal from CPU that causes the 8259A to release vector address on to the data bus.
- **Data Bus Buffer** : This tristate bidirectional buffer interfaces internal 8259A bus to the microprocessor system data bus. Control words, status and vector information pass through data buffer during read or write operations.
- **Read/Write Control Logic**: This circuit accepts and decodes commands from the CPU. This block also allows the status of the 8259A to be transferred on to the data bus.
- **Cascade Buffer/Comparator**: This block stores and compares the ID's all the 8259A used in system. The three I/O pins CAS₀₋₂ are outputs when the 8259A is used as a master. The same pins act as inputs when the 8259A is in slave mode. The 8259A in master mode sends the ID of the interrupting slave device on these lines. The slave thus selected, will send its preprogrammed vector address on the data bus during the next INTA pulse.
- **CS**: This is an active-low chip select signal for enabling RD and WR operations of 8259A. INTA function is independent of CS.

- **WR** : This pin is an active-low write enable input to 8259A. This enables it to accept command words from CPU.
- **RD** : This is an active-low read enable input to 8259A. A low on this line enables 8259A to release status onto the data bus of CPU.
- **D0-D7** : These pins form a bidirectional data bus that carries 8-bit data either to control word or from status word registers. This also carries interrupt vector information.
- **CAS0 – CAS2 Cascade Lines** : A signal 8259A provides eight vectored interrupts. If more interrupts are required, the 8259A is used in cascade mode. In cascade mode, a master 8259A along with eight slaves 8259A can provide upto 64 vectored interrupt lines. These three lines act as select lines for addressing the slave 8259A.
- **PS/EN** : This pin is a dual purpose pin. When the chip is used in buffered mode, it can be used as buffered enable to control buffer transreceivers. If this is not used in buffered mode then the pin is used as input to designate whether the chip is used as a master (SP =1) or slave (EN = 0).
- **INT** : This pin goes high whenever a valid interrupt request is asserted. This is used to interrupt the CPU and is connected to the interrupt input of CPU.
- **IR0 – IR7 (Interrupt requests)** :These pins act as inputs to accept interrupt request to the CPU. In edge triggered mode, an interrupt service is requested by raising an IR pin from a low to a high state and holding it high until it is acknowledged, and just by latching it to high level, if used in level triggered mode.

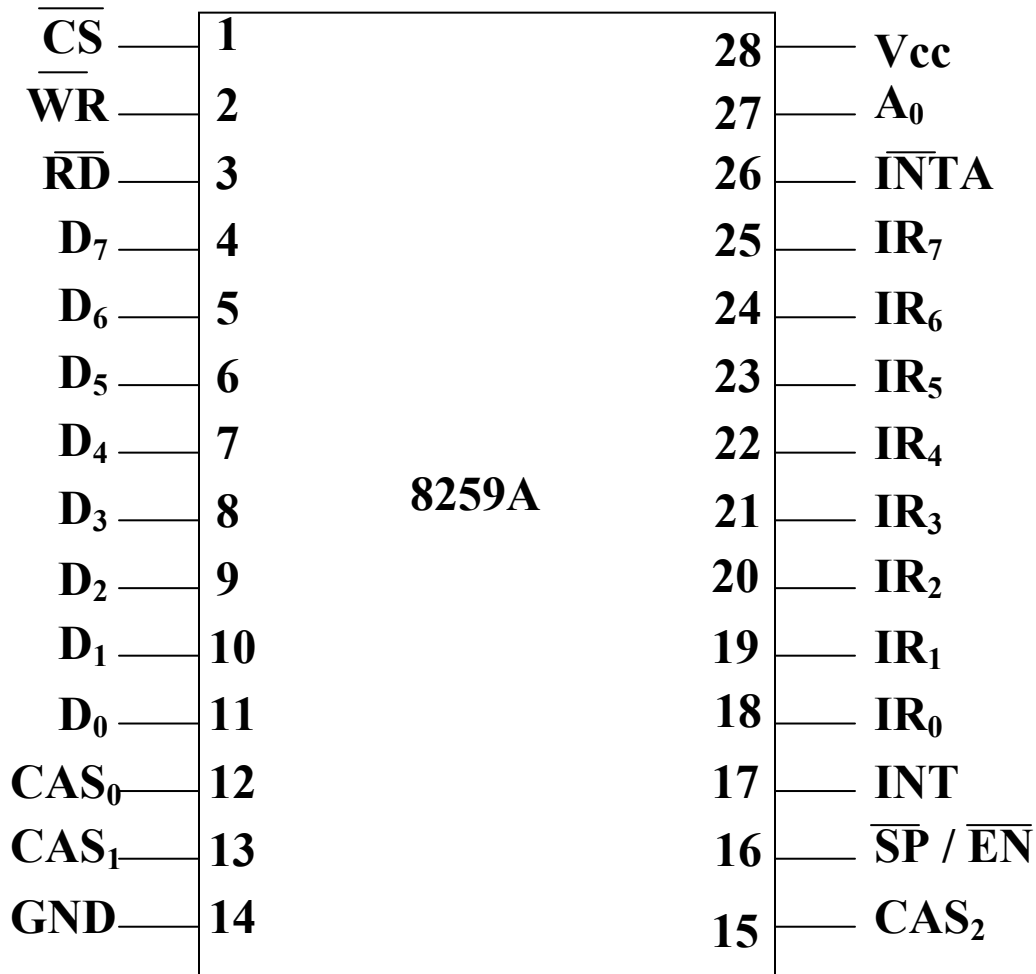

Fig : 8259 Pin Diagram

- **INTA (Interrupt acknowledge):** This pin is an input used to strobe-in 8259A interrupt vector data on to the data bus. In conjunction with CS, WR and RD pins, this selects the different operations like, writing command words, reading status word, etc.
- The device 8259A can be interfaced with any CPU using either polling or interrupt. In polling, the CPU keeps on checking each peripheral device in sequence to ascertain if it requires any service from the CPU. If any such service request is noticed, the CPU serves the request and then goes on to the next device in sequence.
- After all the peripheral device are scanned as above the CPU again starts from first device.
- This type of system operation results in the reduction of processing speed because most of the CPU time is consumed in polling the peripheral devices.
- In the interrupt driven method, the CPU performs the main processing task till it is interrupted by a service requesting peripheral device.
- The net processing speed of these type of systems is high because the CPU serves the peripheral only if it receives the interrupt request.

- If more than one interrupt requests are received at a time, all the requesting peripherals are served one by one on priority basis.
- This method of interfacing may require additional hardware if number of peripherals to be interfaced is more than the interrupt pins available with the CPU.

Interrupt Sequence in an 8086 system

- The Interrupt sequence in an 8086-8259A system is described as follows:
 1. One or more IR lines are raised high that set corresponding IRR bits.
 2. 8259A resolves priority and sends an INT signal to CPU.
 3. The CPU acknowledge with INTA pulse.
 4. Upon receiving an INTA signal from the CPU, the highest priority ISR bit is set and the corresponding IRR bit is reset. The 8259A does not drive data during this period.
 5. The 8086 will initiate a second INTA pulse. During this period 8259A releases an 8-bit pointer on to a data bus from where it is read by the CPU.
 6. This completes the interrupt cycle. The ISR bit is reset at the end of the second INTA pulse if automatic end of interrupt (AEIOI) mode is programmed. Otherwise ISR bit remains set until an appropriate EOI command is issued at the end of interrupt subroutine.

Command Words of 8259A

- The command words of 8259A are classified in two groups
 1. Initialization command words (ICW) and
 2. Operation command words (OCW).
- Initialization Command Words (ICW): Before it starts functioning, the 8259A must be initialized by writing two to four command words into the respective command word registers. These are called as initialized command words.
- If $A_0 = 0$ and $D_4 = 1$, the control word is recognized as ICW1. It contains the control bits for edge/level triggered mode, single/cascade mode, call address interval and whether ICW4 is required or not.
- If $A_0 = 1$, the control word is recognized as ICW2. The ICW2 stores details regarding interrupt vector addresses. The initialisation sequence of 8259A is described in form of a flow chart in fig 3 below.
- The bit functions of the ICW1 and ICW2 are self explanatory as shown in fig below.

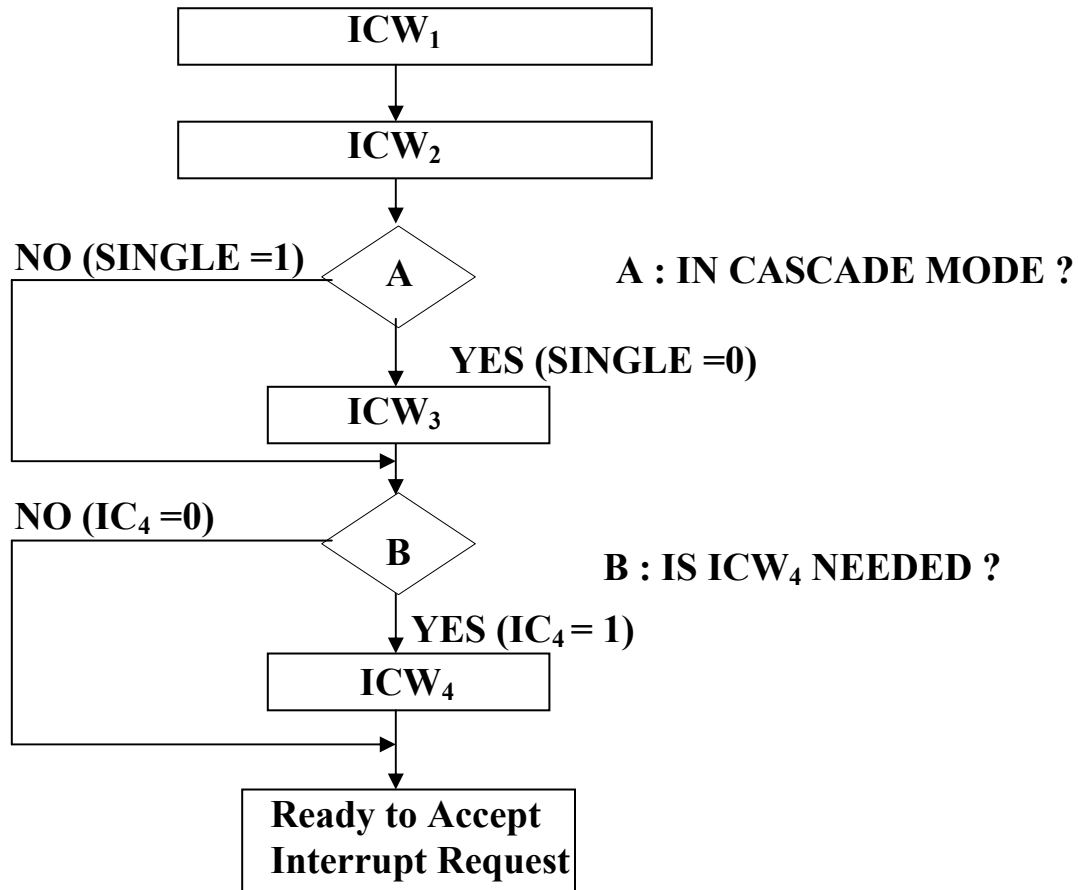
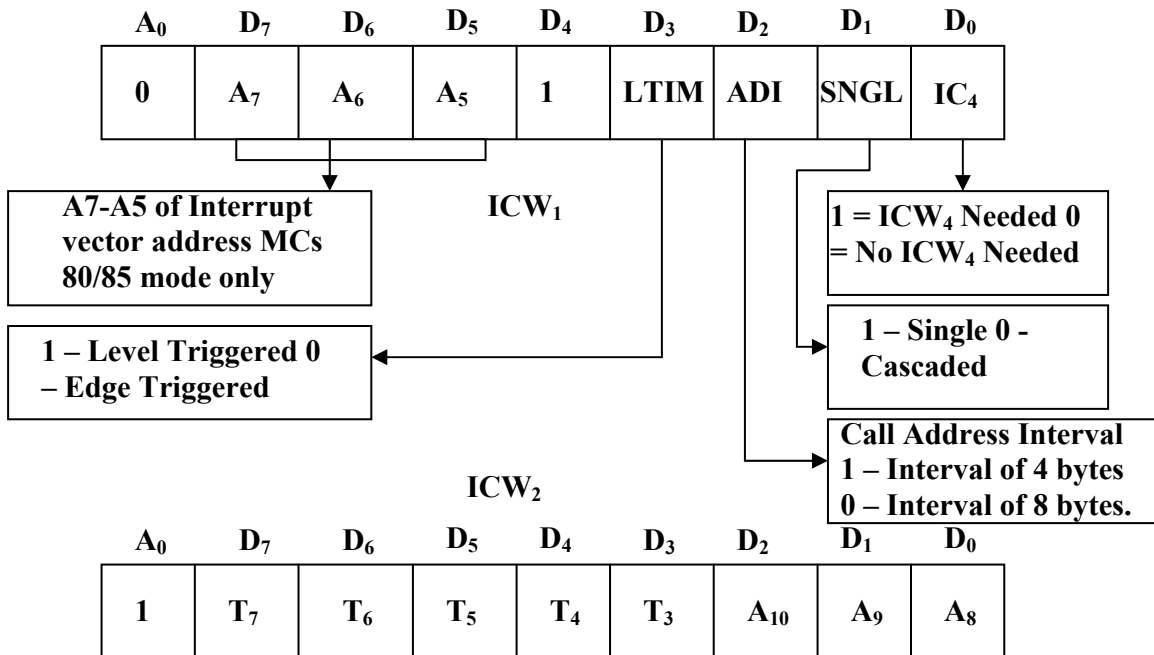

Fig 3: Initialisation Sequence of 8259A



- T₇ – T₃ are A₃ – A₀ of interrupt address
- A₁₀ – A₉, A₈ – Selected according to interrupt request level.
They are not the address lines of Microprocessor
- A₀ = 1 selects ICW₂

Fig 4 : Instruction Command Words ICW₁ and

- Once ICW₁ is loaded, the following initialization procedure is carried out internally.
 - a. The edge sense circuit is reset, i.e. by default 8259A interrupts are edge sensitive.
 - b. IMR is cleared.
 - c. IR₇ input is assigned the lowest priority.
 - d. Slave mode address is set to 7.
 - e. Special mask mode is cleared and status read is set to IRR.
 - f. If IC₄ = 0, all the functions of ICW₄ are set to zero. Master/Slave bit in ICW₄ is used in the buffered mode only.
 - g. In an 8085 based system A₁₅-A₈ of the interrupt vector address are the respective bits of ICW₂.
 - h. In 8086 based system A₁₅-A₁₁ of the interrupt vector address are inserted in place of T₇ – T₃ respectively and the remaining three bits A₈, A₉, A₁₀ are selected depending upon the interrupt level, i.e. from 000 to 111 for IR₀ to IR₇.
 - i. ICW₁ and ICW₂ are compulsory command words in initialization sequence of 8259A as is evident from fig, while ICW₃ and ICW₄ are optional. The ICW₃ is read only when there are more than one 8259A in the system, cascading is used (SNGL=0).
 - j. The SNGL bit in ICW₁ indicates whether the 8259A in the cascade mode or not. The ICW₃ loads an 8-bit slave register. Its detailed functions are as follows.
 - k. In master mode [SP = 1 or in buffer mode M/S = 1 in ICW₄], the 8-bit slave register will be set bit-wise to 1 for each slave in the system as in fig 5.

- The requesting slave will then release the second byte of a CALL sequence. In slave mode [SP=0 or if BUF =1 and M/S = 0 in ICW4] bits D2 to D0 identify the slave, i.e. 000 to 111 for slave 1 to slave 8. The slave compares the cascade inputs with these bits and if they are equal, the second byte of the CALL sequence is released by it on the data bus.

Master mode ICW₃

A ₀	D ₇	D ₆	D ₅	D ₄	D ₃	D ₂	D ₁	D ₀
1	S ₇	S ₆	S ₅	S ₄	S ₃	S ₂	S ₁	S ₀

**S_n = 1-IR_n Input has a slave = 0 – IR_n
Input does not have a slave**

Slave mode ICW₃

A ₀	D ₇	D ₆	D ₅	D ₄	D ₃	D ₂	D ₁	D ₀
1	0	0	0	0	0	ID ₂	ID ₁	ID ₀

D₂D₁D₀ – 000 to 111 for IR₀ to IR₇ or slave 1 to slave 8

ICW₄

A ₀	D ₇	D ₆	D ₅	D ₄	D ₃	D ₂	D ₁	D ₀
1	0	0	0	SFNM	BUF	M/S	AEOI	μPM

Fig : ICW₃ in Master and Slave Mode, ICW₄ Bit Functions

- ICW₄**: The use of this command word depends on the IC4 bit of ICW1. If IC4=1, IC4 is used, otherwise it is neglected. The bit functions of ICW4 are described as follow:
- SFNM**: If BUF = 1, the buffered mode is selected. In the buffered mode, SP/EN acts as enable output and the master/slave is determined using the M/S bit of ICW4.
- M/S**: If M/S = 1, 8259A is a master. If M/S =0, 8259A is slave. If BUF = 0, M/S is to be neglected.
- AEOI**: If AEOI = 1, the automatic end of interrupt mode is selected.
- μPM** : If the μPM bit is 0, the Mcs-85 system operation is selected and if μPM=1, 8086/88 operation is selected.
- Operation Command Words**: Once 8259A is initialized using the previously discussed command words for initialisation, it is ready for its normal function, i.e. for accepting the interrupts but 8259A has its own way of handling the received

interrupts called as modes of operation. These modes of operations can be selected by programming, i.e. writing three internal registers called as operation command words.

- In the three operation command words OCW1, OCW2 and OCW3 every bit corresponds to some operational feature of the mode selected, except for a few bits those are either 1 or 0. The three operation command words are shown in fig with the bit selection details.
- OCW1 is used to mask the masked and if it is 0 the request is enabled. In OCW2 the three bits, R, SL and EOI control the end of interrupt, the rotate mode and their combinations as shown in fig below.
- The three bits L2, L1 and L0 in OCW2 determine the interrupt level to be selected for operation, if SL bit is active i.e. 1.
- The details of OCW2 are shown in fig.
- In operation command word 3 (OCW3), if the ESMM bit, i.e. enable special mask mode bit is set to 1, the SMM bit is neglected. If the SMM bit, i.e. special mask mode. When ESMM bit is 0 the SMM bit is neglected. If the SMM bit. i.e. special mask mode bit is 1, the 8259A will enter special mask mode provided ESMM=1.
- If ESMM=1 and SMM=0, the 8259A will return to the normal mask mode. The details of bits of OCW3 are given in fig along with their bit definitions.

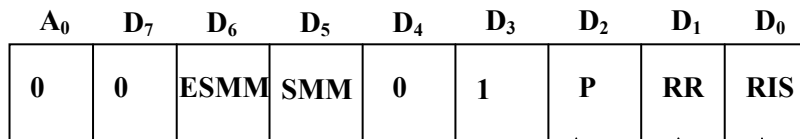
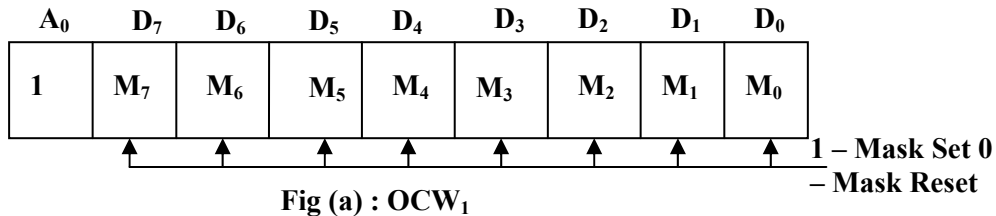

Fig (b) :

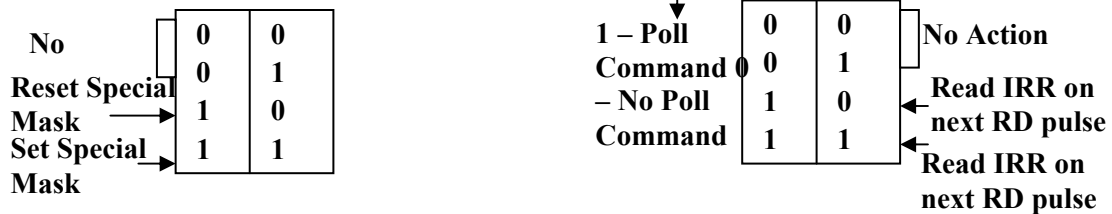

Fig : Operation Command Words

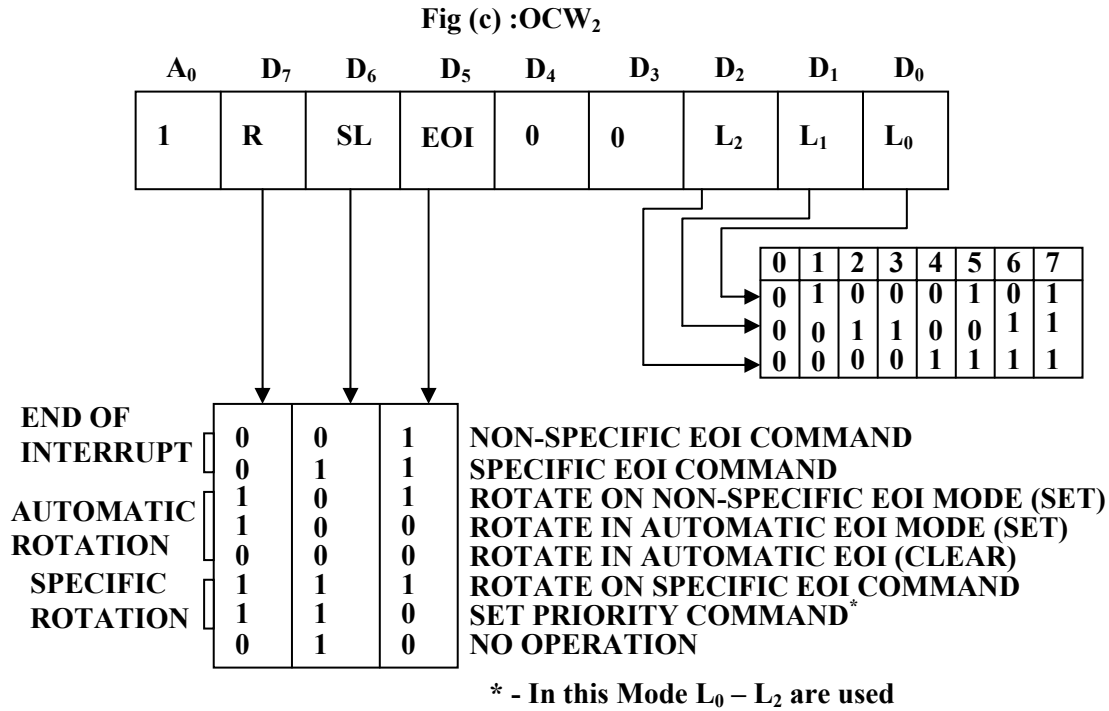

Fig : Operation Command Word

Operating Modes of 8259

- The different modes of operation of 8259A can be programmed by setting or resting the appropriate bits of the ICW or OCW as discussed previously. The different modes of operation of 8259A are explained in the following.
- **Fully Nested Mode** : This is the default mode of operation of 8259A. IR0 has the highest priority and IR7 has the lowest one. When interrupt request are noticed, the highest priority request amongst them is determined and the vector is placed on the data bus. The corresponding bit of ISR is set and remains set till the microprocessor issues an EOI command just before returning from the service routine or the AEOI bit is set.
- If the ISR (in service) bit is set, all the same or lower priority interrupts are inhibited but higher levels will generate an interrupt, that will be acknowledge only if the microprocessor interrupt enable flag IF is set. The priorities can afterwards be changed by programming the rotating priority modes.
- **End of Interrupt (EOI)** : The ISR bit can be reset either with AEOI bit of ICW1 or by EOI command, issued before returning from the interrupt service routine. There are two types of EOI commands specific and non-specific. When 8259A is operated in the modes that preserve fully nested structure, it can determine which ISR bit is to be reset on EOI.
- When non-specific EOI command is issued to 8259A it will be automatically reset the highest ISR bit out of those already set.
- When a mode that may disturb the fully nested structure is used, the 8259A is no longer able to determine the last level acknowledged. In this case a specific EOI command is issued to reset a particular ISR bit. An ISR bit that is masked by the

corresponding IMR bit, will not be cleared by non-specific EOI of 8259A, if it is in special mask mode.

- **Automatic Rotation** : This is used in the applications where all the interrupting devices are of equal priority.
- In this mode, an interrupt request IR level receives priority after it is served while the next device to be served gets the highest priority in sequence. Once all the device are served like this, the first device again receives highest priority.
- **Automatic EOI Mode** : Till AEOI=1 in ICW4, the 8259A operates in AEOI mode. In this mode, the 8259A performs a non-specific EOI operation at the trailing edge of the last INTA pulse automatically. This mode should be used only when a nested multilevel interrupt structure is not required with a single 8259A.
- **Specific Rotation** : In this mode a bottom priority level can be selected, using L2, L1 and L0 in OCW2 and R=1, SL=1, EOI=0.
- The selected bottom priority fixes other priorities. If IR5 is selected as a bottom priority, then IR5 will have least priority and IR4 will have a next higher priority. Thus IR6 will have the highest priority.
- These priorities can be changed during an EOI command by programming the rotate on specific EOI command in OCW2.
- **Specific Mask Mode**: In specific mask mode, when a mask bit is set in OCW1, it inhibits further interrupts at that level and enables interrupt from other levels, which are not masked.
- **Edge and Level Triggered Mode** : This mode decides whether the interrupt should be edge triggered or level triggered. If bit LTIM of ICW1 =0 they are edge triggered, otherwise the interrupts are level triggered.
- **Reading 8259 Status** : The status of the internal registers of 8259A can be read using this mode. The OCW3 is used to read IRR and ISR while OCW1 is used to read IMR. Reading is possible only in no polled mode.
- **Poll Command** : In polled mode of operation, the INT output of 8259A is neglected, though it functions normally, by not connecting INT output or by masking INT input of the microprocessor. The poll mode is entered by setting P=1 in OCW3.
- The 8259A is polled by using software execution by microprocessor instead of the requests on INT input. The 8259A treats the next RD pulse to the 8259A as an interrupt acknowledge. An appropriate ISR bit is set, if there is a request. The priority level is read and a data word is placed on to data bus, after RD is activated. A poll command may give more than 64 priority levels.

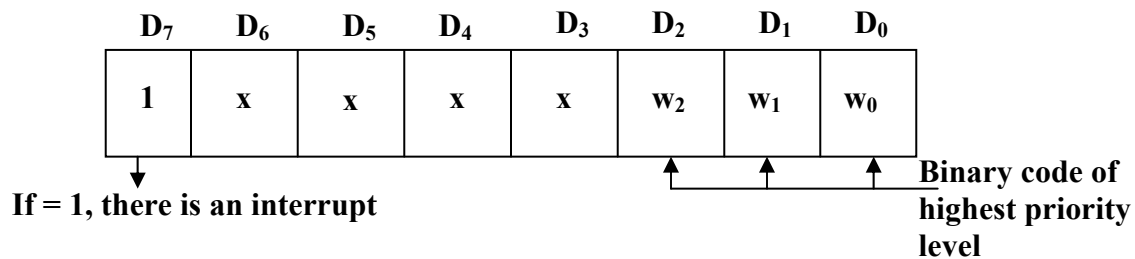
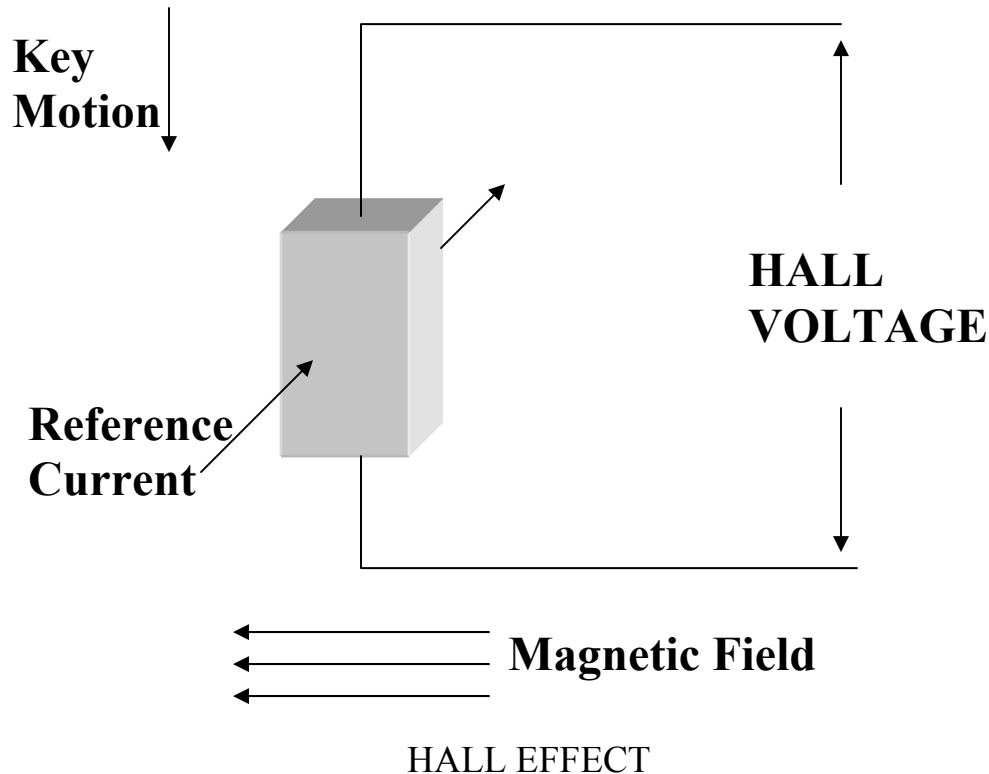

Fig : Data Word of 8259

- **Special Fully Nested Mode** : This mode is used in more complicated system, where cascading is used and the priority has to be programmed in the master using ICW4. this is somewhat similar to the normal nested mode.
- In this mode, when an interrupt request from a certain slave is in service, this slave can further send request to the master, if the requesting device connected to the slave has higher priority than the one being currently served. In this mode, the master interrupt the CPU only when the interrupting device has a higher or the same priority than the one current being served. In normal mode, other requests than the one being served are masked out.
- When entering the interrupt service routine the software has to check whether this is the only request from the slave. This is done by sending a non-specific EOI can be sent to the master, otherwise no EOI should be sent. This mode is important, since in the absence of this mode, the slave would interrupt the master only once and hence the priorities of the slave inputs would have been disturbed.
- **Buffered Mode**: When the 8259A is used in the systems where bus driving buffers are used on data buses. The problem of enabling the buffers exists. The 8259A sends buffer enable signal on SP/ EN pin, whenever data is placed on the bus.
- **Cascade Mode** : The 8259A can be connected in a system containing one master and eight slaves (maximum) to handle upto 64 priority levels. The master controls the slaves using CAS0-CAS2 which act as chip select inputs (encoded) for slaves.
- In this mode, the slave INT outputs are connected with master IR inputs. When a slave request line is activated and acknowledged, the master will enable the slave to release the vector address during second pulse of INTA sequence.
- The cascade lines are normally low and contain slave address codes from the trailing edge of the first INTA pulse to the trailing edge of the second INTA pulse. Each 8259A in the system must be separately initialized and programmed to work in different modes. The EOI command must be issued twice, one for master and the other for the slave.
- A separate address decoder is used to activate the chip select line of each 8259A.
- Following Fig shows the details of the circuit connections of 8259A in cascade scheme.

- When u press a key, you push the top ink line through the hole to contact the bottom ink line.
 - The advantages of membrane keyboards is that they can be made as very thin, sealed units.
 - They are often used on cash registers in fast food restaurants. The lifetime of membrane keyboards varies over a wide range.
3. **Capacitive key switches:** A capacitive keyswitch has two small metal plates on the printed circuit board and another metal plate on the bottom of a piece of foam.
- When u press the key, the movable plate is pushed closer to fixed plate. This changes the capacitance between the fixed plates. Sense amplifier circuitry detects this change in capacitance and produce a logic level signal that indicates a key has been pressed.
 - The big advantages of a capacitive switch is that it has no mechanical contacts to become oxidized or dirty.
 - A small disadvantage is the specified circuitry needed to detect the change in capacitance.
 - Capacitive keyswitches typically have a rated lifetime of about 20 million keystrokes.
4. **Hall effect keyswitches:** This is another type of switch which has no mechanical contact. It takes advantage of the deflection of a moving charge by a magnetic field.
- A reference current is passed through a semiconductor crystal between two opposing faces. When a key is pressed, the crystal is moved through a magnetic field which has its flux lines perpendicular to the direction of current flow in the crystal.
 - Moving the crystal through the magnetic field causes a small voltage to be developed between two of the other opposing faces of the crystal.
 - This voltage is amplified and used to indicate that a key has been pressed. Hall effect sensors are also used to detect motion in many electrically controlled machines.
 - Hall effect keyboards are more expensive because of the more complex switch mechanism, but they are very dependable and have typically rated lifetime of 100 million or more keystrokes.



Keyboard Circuit Connections and Interfacing

- In most keyboards, the keyswitches are connecting in a matrix of rows and columns, as shown in fig.
- We will use simple mechanical switches for our examples, but the principle is same for other type of switches.
- Getting meaningful data from a keyboard, it requires the following three major tasks:
 1. Detect a keypress.
 2. Debounce the keypress.
 3. Encode the keypress
- Three tasks can be done with hardware, software, or a combination of two, depending on the application.
- 1. Software Keyboard Interfacing:**
 - **Circuit connection and algorithm :** The following fig (a) shows how a hexadecimal keypad can be connected to a couple of microcomputer ports so the three interfacing tasks can be done as part of a program.
 - The rows of the matrix are connected to four output port lines. The column lines of matrix are connected to four input-port lines. To make the program simpler, the row lines are also connected to four input lines.
 - When no keys are pressed, the column lines are held high by the pull-up resistor connected to +5V. Pressing a key connects a row to a column. If a low is output on a row and a key in that row is pressed, then the low will appear on the column which contains that key and can be detected on the input port.

- If you know the row and column of the pressed key, you then know which key was pressed, and you can convert this information into any code you want to represent that key.
- The following flow chart for a procedure to detect, debounce and produce the hex code for a pressed key.
- An easy way to detect if any key in the matrix is pressed is to output 0's to all rows and then check the column to see if a pressed key has connected a low to a column.
- In the algorithm we first output lows to all the rows and check the columns over and over until the column are all high. This is done before the previous key has been released before looking for the next one. In the standard keyboard terminology, this is called two-key lockout.

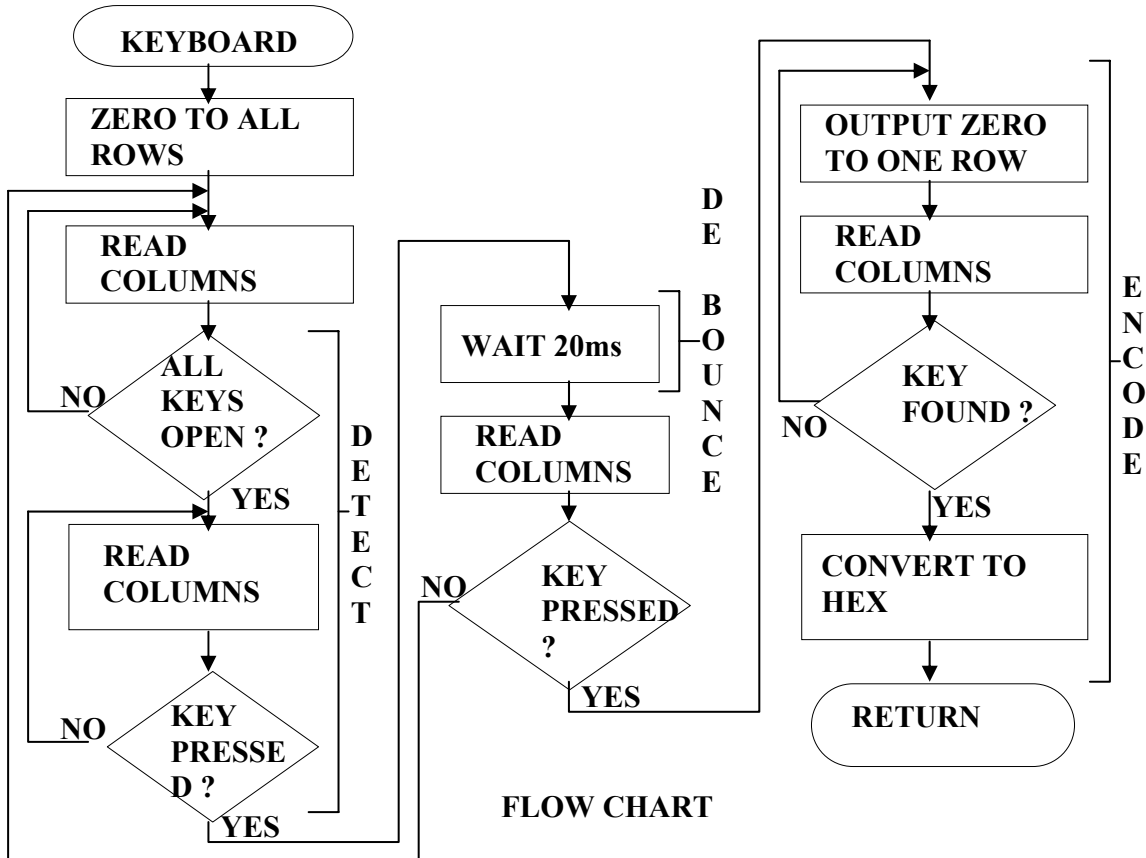

- Once the columns are found to be all high, the program enters another loop, which waits until a low appears on one of the columns, indicating that a key has been pressed. This second loop does the detect task for us. A simple 20-ms delay procedure then does the debounce task.
- After the debounce time, another check is made to see if the key is still pressed. If the columns are now all high, then no key is pressed and the initial detection was caused by a noise pulse or a light brushing past a key. If any of the columns are still low, then the assumption is made that it was a valid keypress.
- The final task is to determine the row and column of the pressed key and convert this row and column information to the hex code for the pressed key. To get the row and column information, a low is output to one row and the column are read.

- If none of the columns is low, the pressed key is not in that row. So the low is rotated to the next row and the column are checked again. The process is repeated until a low on a row produces a low on one of the column.
- The pressed key then is in the row which is low at that time.
 - The connection fig shows the byte read in from the input port will contain a 4-bit code which represents the row of the pressed key and a 4-bit code which represent the column of the pressed key.
 - **Error trapping:** The concept of detecting some error condition such as “ no match found” is called error trapping. Error trapping is a very important part of real programs. Even in simple programs, think what might happen with no error trap if two keys in the same row were pressed at exactly at the same time and a column code with two lows in it was produced.
 - This code would not match any of the row-column codes in the table, so after all the values in the table were checked, assigned register in program would be decremented from 0000H to FFFFH. The compare decrement cycle would continue through 65,536 memory locations until, by change the value in a memory location matched the row-column code. The contents of the lower byte register at that point would be passed back to the calling routine. The changes are 1 in 256 that would be the correct value for one of the pressed keys. You should keep an error trap in a program whenever there is a chance for it.
2. **Keyboard Interfacing with Hardware:** For the system where the CPU is too busy to be bothered doing these tasks in software, an external device is used to do them.
- One of a MOS device which can be do this is the General Instruments AY5-2376 which can be connected to the rows and columns of a keyboard switch matrix.
 - The AY5-2376 independently detects a keypress by cycling a low down through the rows and checking the columns. When it finds a key pressed, it waits a debounce time.
 - If the key is still pressed after the debounce time, the AY5-2376 produces the 8-bit code for the pressed key and send it out to microcomputer port on 8 parallel lines. The microcomputer knows that a valid ASCII code is on the data lines, the AY5-2376 outputs a strobe pulse.
 - The microcomputer can detect this strobe pulse and read in ASCII code on a polled basis or it can detect the strobe pulse on an interrupt basis.
 - With the interrupt method the microcomputer doesn't have to pay any attention to the keyboard until it receives an interrupt signal.
 - So this method uses very little of the microcomputer time. The AY5-2376 has a feature called *two-key rollover*. This means that if two keys are pressed at nearly the same time, each key will be detected, debounced and converted to ASCII.
 - The ASCII code for the first key and a strobe signal for it will be sent out then the ASCII code for the second key and a strobe signal for it will be sent out and compare this with two-key lockout.

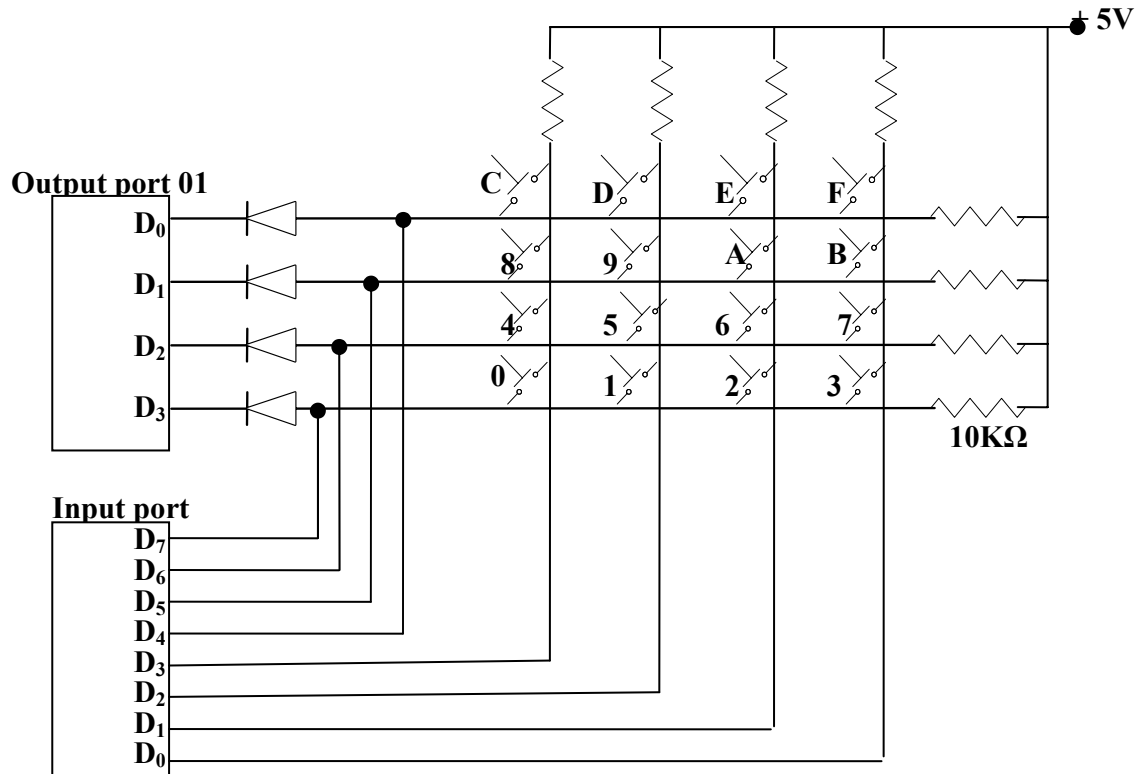
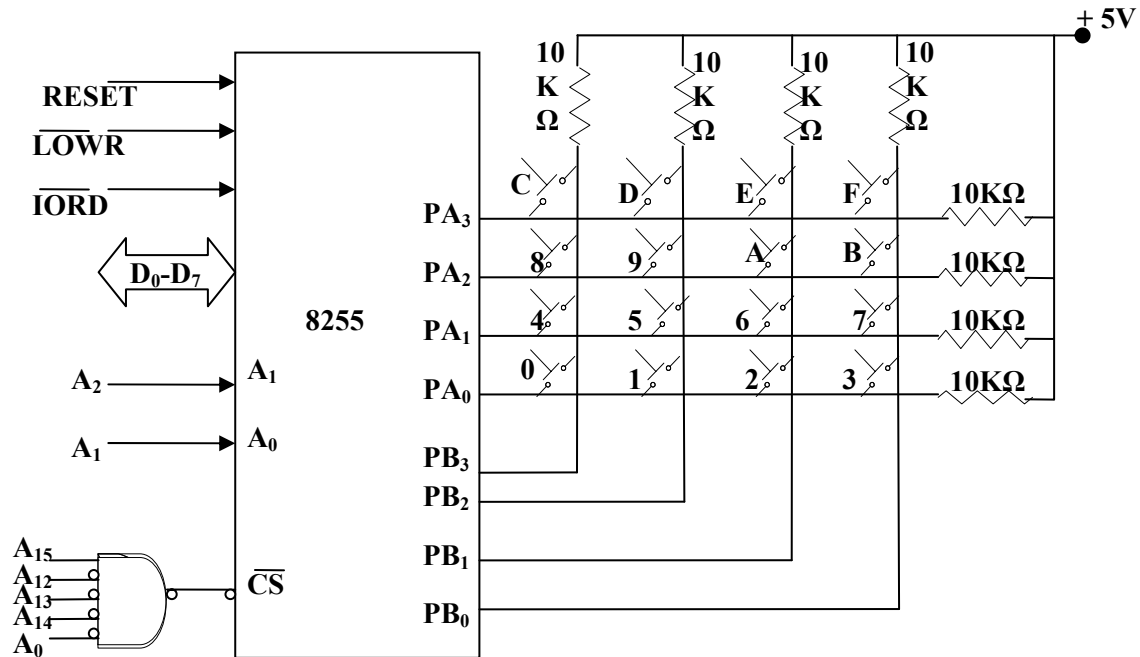

Fig: (a) Port connections

Example

- Interface a 4 * 4 keyboard with 8086 using 8255 and write an ALP for detecting a key closure and return the key code in AL. The debounce period for a key is 10ms. Use software debouncing technique. DEBOUNCE is an available 10ms delay routine.
- Solution: Port A is used as output port for selecting a row of keys while Port B is used as an input port for sensing a closed key. Thus the keyboard lines are selected one by one through port A and the port B lines are polled continuously till a key closure is sensed. The routine DEBOUNCE is called for key debouncing. The key code is depending upon the selected row and a low sensed column.



Interfacing 4 * 4 Keyboard

- The higher order lines of port A and port B are left unused. The address of port A and port B will respectively 8000H and 8002H while address of CWR will be 8006H. The flow chart of the complete program is as given. The control word for this problem will be 82H. Code segment CS is used for storing the program code.
- **Key Debounce** : Whenever a mechanical push-button is pressed or released once, the mechanical components of the key do not change the position smoothly, rather it generates a transient response .

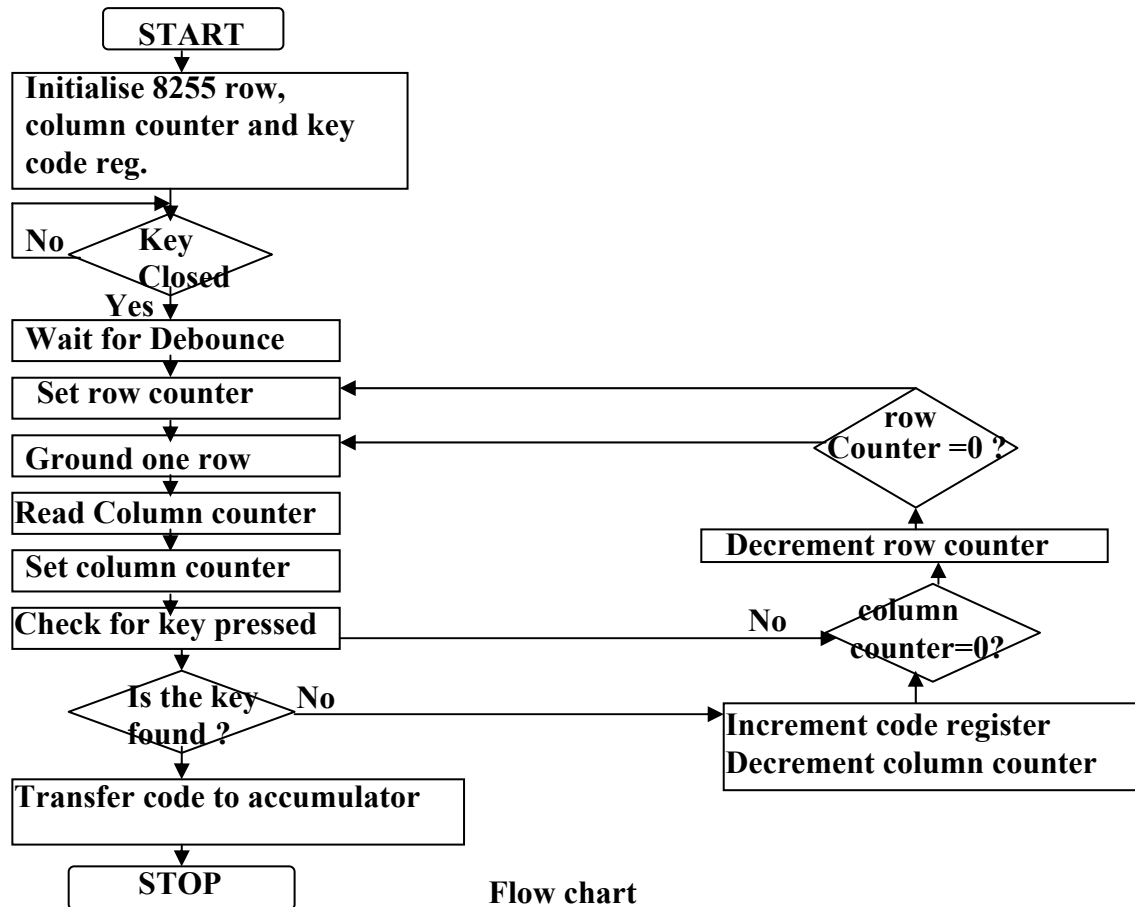

- These transient variations may be interpreted as the multiple key pressure and responded accordingly by the microprocessor system.
- To avoid this problem, two schemes are suggested: the first one utilizes a bistable multivibrator at the output of the key to debounce .
- The other scheme suggests that the microprocessor should be made to wait for the transient period (usually 10ms), so that the transient response settles down and reaches a steady state.
- A logic '0' will be read by the microprocessor when the key is pressed.
- In a number of high precision applications, a designer may have two options- the first is to have more than one 8-bit port, read (write) the port one by one and then from the multibyte data, the second option allows forming 16-bit ports using two 8-bit ports and use 16-bit read or write operations.

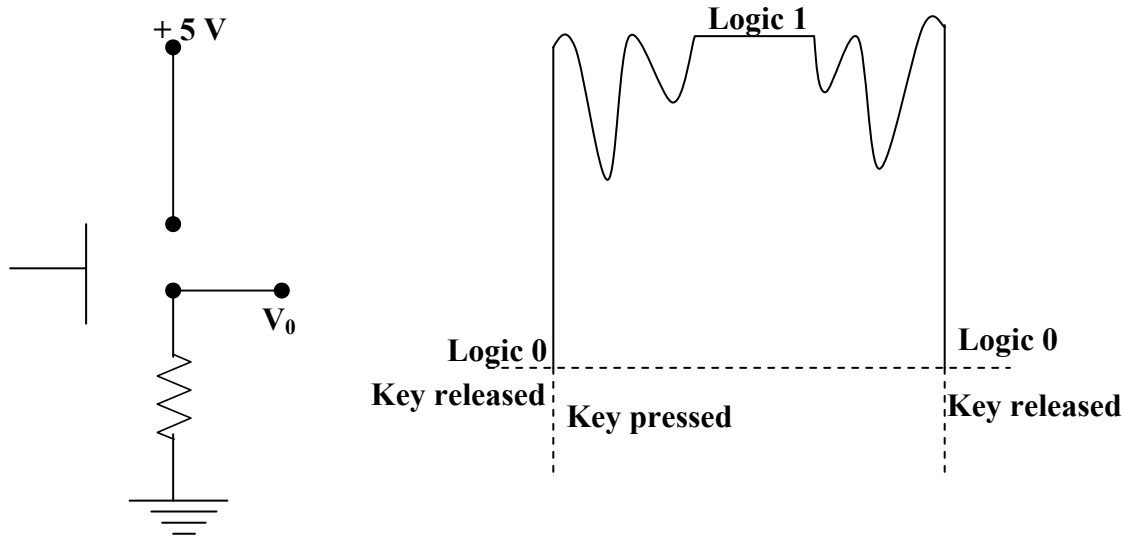

A Mechanical Key

Response

Interfacing To Alphanumeric Displays

- To give directions or data values to users, many microprocessor-controlled instruments and machines need to display letters of the alphabet and numbers. In systems where a large amount of data needs to be displayed a CRT is used to display the data. In system where only a small amount of data needs to be displayed, simple digit-type displays are often used.
 - There are several technologies used to make these digit-oriented displays but we are discussing only the two major types.
 - These are *light emitting diodes* (LED) and *liquid-crystal displays* (LCD).
 - LCD displays use very low power, so they are often used in portable, battery-powered instruments. They do not emit their own light, they simply change the reflection of available light. Therefore, for an instrument that is to be used in low-light conditions, you have to include a light source for LCDs or use LEDs which emit their own light.
 - Alphanumeric LED displays are available in three common formats. For displaying only number and hexadecimal letters, simple 7-segment displays such as that as shown in fig are used.
 - To display numbers and the entire alphabet, 18 segment displays such as shown in fig or 5 by 7 dot-matrix displays such as that shown in fig can be used. The 7-segment type is the least expensive, most commonly used and easiest to interface with, so we will concentrate first on how to interface with this type.
- Directly Driving LED Displays:** Figure shows a circuit that you might connect to a parallel port on a microcomputer to drive a single 7-segment, common-anode display. For a common-anode display, a segment is turned on by applying a logic low to it.
 - The 7447 converts a BCD code applied to its inputs to the pattern of lows required to display the number represented by the BCD code. This circuit connection is referred to as a *static display* because current is being passed through the display at all times.

- Each segment requires a current of between 5 and 30mA to light. Let's assume you want a current of 20mA. The voltage drop across the LED when it is lit is about 1.5V.
 - The output low voltage for the 7447 is a maximum of 0.4V at 40mA. So assume that it is about 0.2V at 20mA. Subtracting these two voltage drop from the supply voltage of 5V leaves 3.3V across the current limiting resistor. Dividing 3.3V by 20mA gives a value of 168Ω for the current-limiting resistor. The voltage drops across the LED and the output of 7447 are not exactly predictable and exact current through the LED is not critical as long as we don't exceed its maximum rating.
- 2. Software-Multiplexed LED Display:**
- The circuit in fig works for driving just one or two LED digits with a parallel output port. However, this scheme has several problem if you want to drive, eight digits.
 - The first problem is power consumption. For worst-case calculations, assume that all 8 digits are displaying the digit 8, so all 7 segments are all lit. Seven segment time 20mA per segment gives a current of 140mA per digit. Multiplying this by 8 digits gives a total current of 1120mA or 1.12A for 8 digits.
 - A second problem of the static approach is that each display digit requires a separate 7447 decoder, each of which uses of another 13mA. The current required by the decoders and the LED displays might be several times the current required by the reset of the circuitry in the instrument.
 - To solve the problem of the static display approach, we use a *multiplex method*, example for an explanation of the multiplexing.
 - The fig shows a circuit you can add to a couple of microcomputer ports to drive some common anode LED displays in a multiplexed manner. The circuit has only one 7447 and that the segment outputs of the 7447 are bused in parallel to the segment inputs of all the digits.
 - The question that may occur to you on first seeing this is: Aren't all the digits going to display the same number? The answer is that they would if all the digits were turned on at the same time. The tricky of multiplexing displays is that only one display digit is turned on at a time.
 - The PNP transistor is series with the common anode of each digit acts as on/off switch for that digit. Here's how the multiplexing process works.
 - The BCD code for digit 1 is first output from port B to the 7447. the 7447 outputs the corresponding 7-segment code on the segment bus lines. The transistor connected to digit 1 is then turned on by outputting a low to the appropriate bit of port A. All the rest of the bits of port A are made high to make sure no other digits are turned on. After 1 or 2 ms, digit 1 is turned off by outputting all highs to port A.
 - The BCD code for digit 2 is then output to the 7447 on port B, and a word to turn on digit 2 is output on port A.
 - After 1 or 2 ms, digit 2 is turned off and the process is repeated for digit 3. the process is continued until all the digits have had a turn. Then digit 1 and the following digits are lit again in turn.

- A procedure which is called on an interrupt basis every 2ms to keep these displays refreshed with some values stored in a table. With 8 digits and 2ms per digit, you get back to digit 1 every 16ms or about 60 times a second.
- This refresh rate is fast enough so that the digits will each appear to be lit all time. Refresh rates of 40 to 200 times a second are acceptable.
- The immediately obvious advantages of multiplexing the displays are that only one 7447 is required, and only one digit is lit at a time. We usually increase the current per segment to between 40 and 60 mA for multiplexed displays so that they will appear as bright as they would if they were not multiplexed. Even with this increased segment current, multiplexing gives a large saving in power and parts.
- The software-multiplexed approach we have just described can also be used to drive 18-segment LED devices and dot-matrix LED device. For these devices, however you replace the 7447 in fig with ROM which generates the required segment codes when the ASCII code for a character is applied to the address inputs of the ROM.

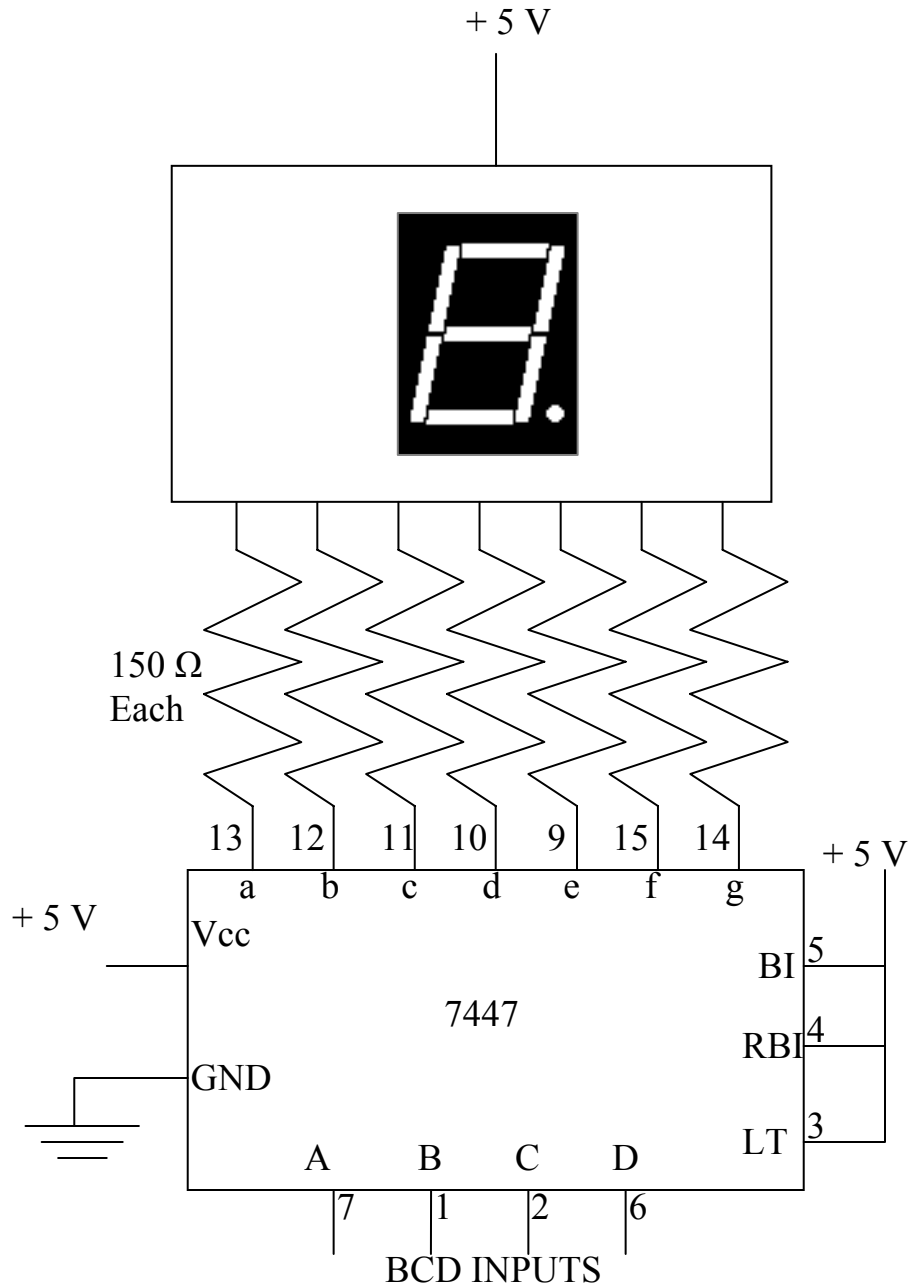

Circuit for driving single 7-segment LED display with 7447

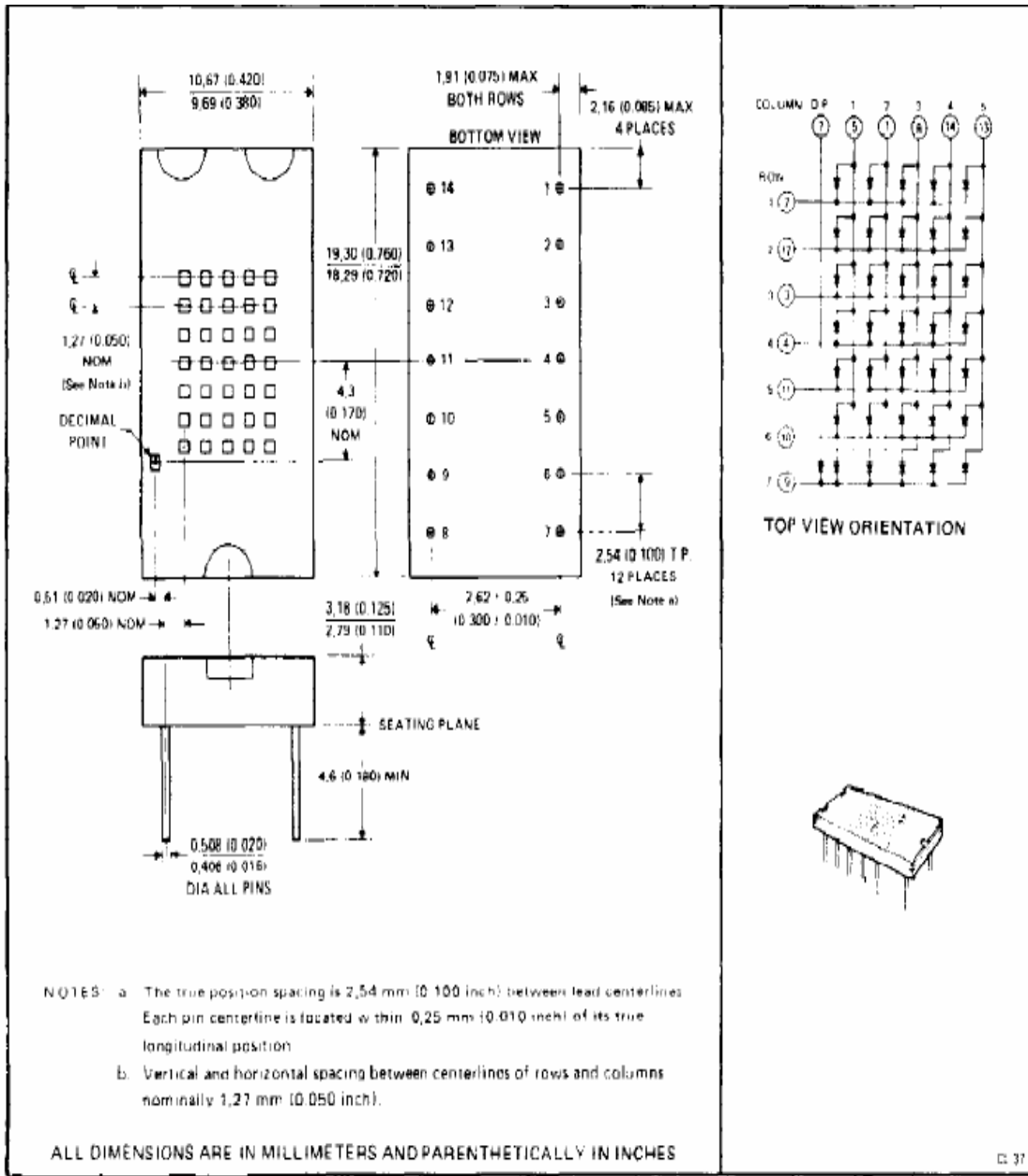

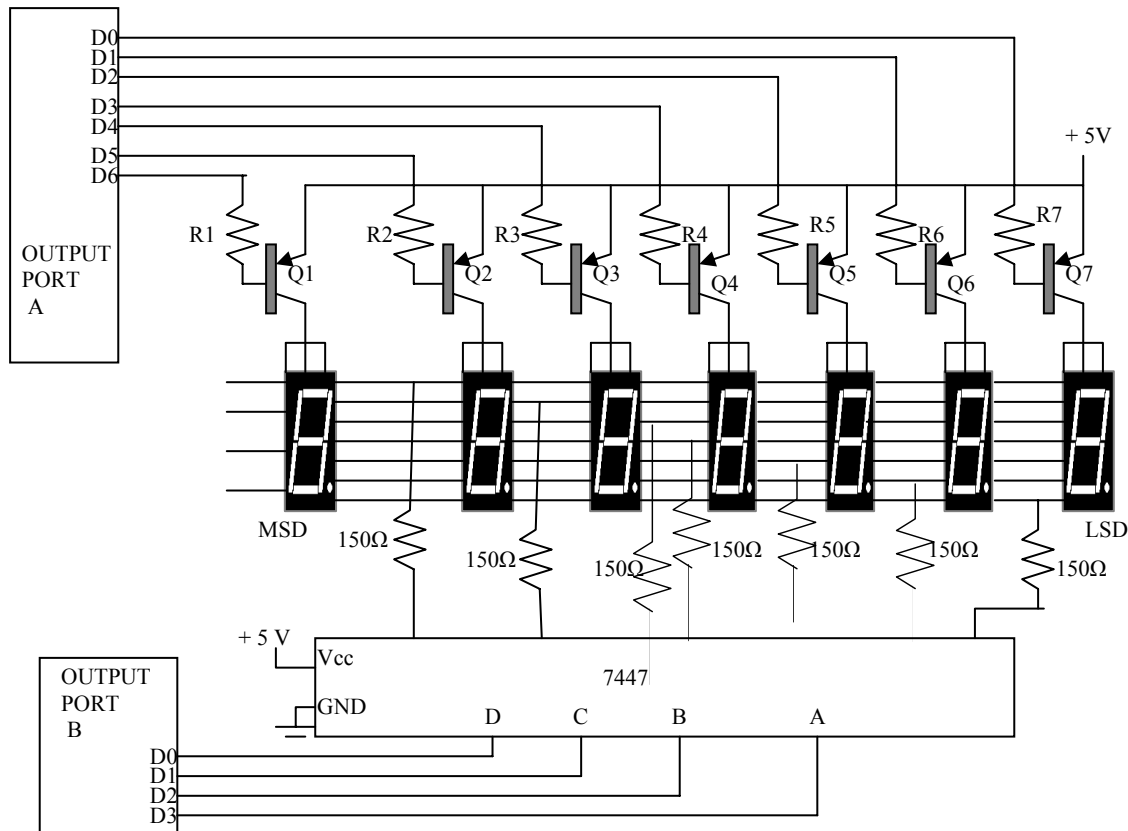

Liquid Crystal Display

- Liquid Crystal displays are created by sandwiching a thin 10-12 μm layer of a liquid-crystal fluid between two glass plates. A transparent, electrically conductive film or backplane is put on the rear glass sheet. Transparent sections of conductive film in the shape of the desired characters are coated on the front glass plate.
- When a voltage is applied between a segment and the backplane, an electric field is created in the region under the segment. This electric field changes the transmission of light through the region under the segment film.
- There are two commonly available types of LCD : dynamic scattering and field-effect.
- The Dynamic scattering types of LCD: It scrambles the molecules where the field is present. This produces an etched-glass-looking light character on a dark background.
- Field-effect types use polarization to absorb light where the electric field is present. This produces dark characters on a silver- gray background.
- Most LCD's require a voltage of 2 or 3 V between the backplane and a segment to turn on the segment.
- We cannot just connect the backplane to ground and drive the segment with the outputs of a TTL decoder. The reason for this is a steady dc voltage of more than about 50mV is applied between a segment and the backplane.
- To prevent a dc buildup on the segments, the segment-drive signals for LCD must be square waves with a frequency of 30 to 150 Hz.

- Even if you pulse the TTL decoder, it still will not work because the output low voltage of TTL devices is greater than 50mV.
- CMOS gates are often used to drive LCDs.
- The Following fig shows how two CMOS gate outputs can be connected to drive an LCD segment and backplane.
- The off segment receives the same drive signal as the backplane. There is never any voltage between them, so no electric field is produced. The waveform for the on segment is 180 out of phase with the backplane signal, so the voltage between this segment and the backplane will always be +V.
- The logic for this signal, a square wave and its complement. To the driving gates, the segment-backplane sandwich appears as a somewhat leaky capacitor.
- The CMOS gates can be easily supply the current required to charge and discharge this small capacitance.
- Older inexpensive LCD displays turn on and off too slowly to be multiplexed the way we do LED display.
- At 0c some LCD may require as mush as 0.5s to turn on or off. To interface to those types we use a nonmultiplexed driver device.
- More expensive LCD can turn on and off faster, so they are often multiplexed using a variety of techniques.
- In the following section we show you how to interface a nonmultiplexed LCD to a microprocessor such as SDK-86.
- Intersil ICM7211M can be connected to drive a 4-digit, nonmultiplexed, 7-segment LCD display.
- The 7211M input can be connected to port pins or directly to microcomputer bus. We have connected the CS inputs to the Y2 output of the 74LS138 port decoder.
- According to the truth table the device will then be addressable as ports with a base address of FF10H. SDK-86 system address lines A2 is connected to the digit-select input (DS2) and system address lines A1 is connected to the DS1 input. This gives digit 4 a system address of FF10H.

A8-A15	A5-A7	A4	A3	A2	A1	A0	M/ \bar{O}	Y Output Selected	System Base Address	Device
1	0	0	0	X	X	0	0	00	FF00	8259A #1
1	0	0	1	X	X	0	0	1	FF08	8259A #2
1	0	1	0	X	X	0	0	2	FF10	
1	0	1	1	X	X	0	0	3	FF18	
1	0	0	0	X	X	1	0	4	FF01	8254
1	0	0	1	X	X	1	0	5	FF09	
1	0	1	0	X	X	1	0	6	FF11	
1	0	1	1	X	X	1	0	7	FF19	
ALL OTHER STATES								NONE		

Fig : Truth table for 74LS138 address decoder

- Digit 3 will be addressed at FF12H, digit 2 at FF14H and digit 1 at FF16H.

- The data inputs are connected to the lower four lines of the SDK-86 data bus. The oscillator input is left open. To display a character on one of the digits, you simply keep the 4-bit hex code for that digit in the lower 4 bits of the AL register and output it to the system address for that digit.
- The ICM7211M converts the 4-bit hex code to the required 7-segment code.
- The rising edge of the CS input signal causes the 7-segment code to be latched in the output latches for the address digit.
- An internal oscillator automatically generates the segment and backplane drive waveforms as in fig . For interfacing with the LCD displays which can be multiplexed the Intersil ICM7233 can be use.

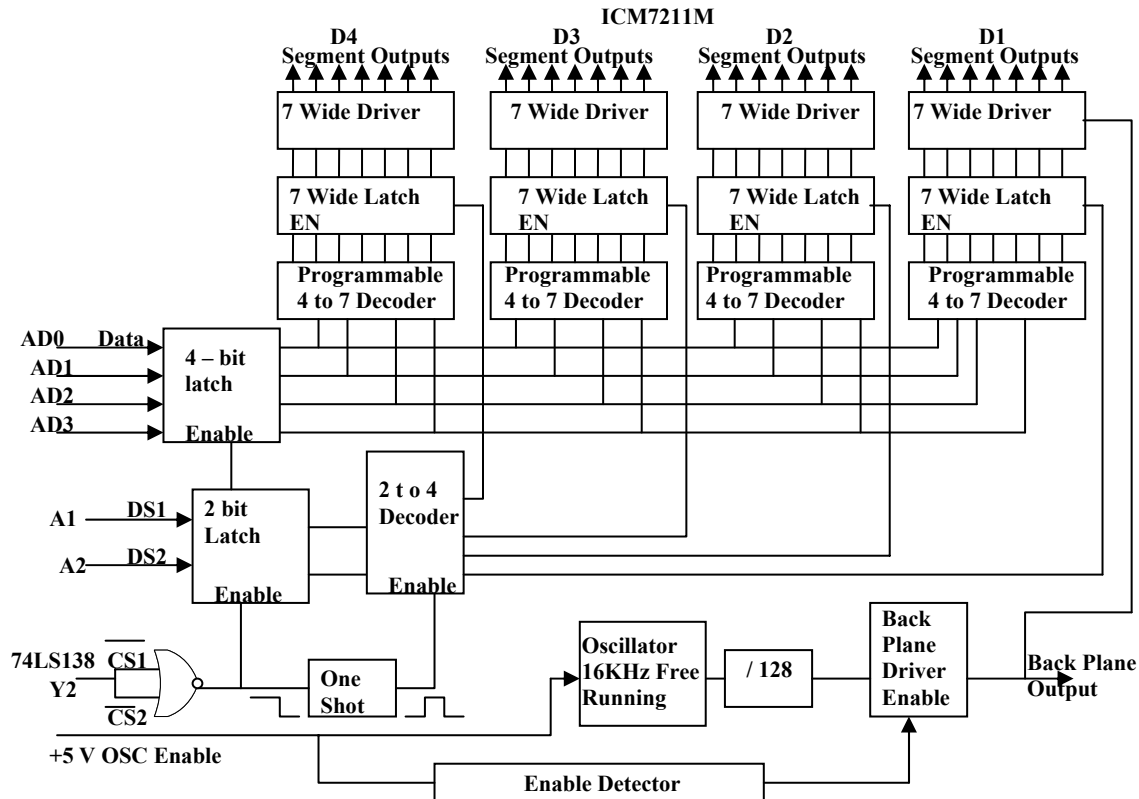

Fig : Circuit for interfacing four LCD digits to an SDK-86 bus using ICM7211M

Interfacing Analog to Digital Data Converters

- In most of the cases, the PIO 8255 is used for interfacing the analog to digital converters with microprocessor.
- We have already studied 8255 interfacing with 8086 as an I/O port, in previous section. This section we will only emphasize the interfacing techniques of analog to digital converters with 8255.
- The analog to digital converters is treated as an input device by the microprocessor, that sends an initialising signal to the ADC to start the analogy to digital data conversation process. The start of conversation signal is a pulse of a specific duration.
- The process of analog to digital conversion is a slow process, and the microprocessor has to wait for the digital data till the conversion is over. After the conversion is over, the ADC sends end of conversion EOC signal to inform the

- microprocessor that the conversion is over and the result is ready at the output buffer of the ADC. These tasks of issuing an SOC pulse to ADC, reading EOC signal from the ADC and reading the digital output of the ADC are carried out by the CPU using 8255 I/O ports.
- The time taken by the ADC from the active edge of SOC pulse till the active edge of EOC signal is called as the conversion delay of the ADC.
 - It may range any where from a few microseconds in case of fast ADC to even a few hundred milliseconds in case of slow ADCs.
 - The available ADC in the market use different conversion techniques for conversion of analog signal to digitals. Successive approximation techniques and dual slope integration techniques are the most popular techniques used in the integrated ADC chip.
 - General algorithm for ADC interfacing contains the following steps:
 1. Ensure the stability of analog input, applied to the ADC.
 2. Issue start of conversion pulse to ADC
 3. Read end of conversion signal to mark the end of conversion processes.
 4. Read digital data output of the ADC as equivalent digital output.
 5. Analog input voltage must be constant at the input of the ADC right from the start of conversion till the end of the conversion to get correct results. This may be ensured by a sample and hold circuit which samples the analog signal and holds it constant for a specific time duration. The microprocessor may issue a hold signal to the sample and hold circuit.
 6. If the applied input changes before the complete conversion process is over, the digital equivalent of the analog input calculated by the ADC may not be correct.

ADC 0808/0809 :

- The analog to digital converter chips 0808 and 0809 are 8-bit CMOS, successive approximation converters. This technique is one of the fast techniques for analog to digital conversion. The conversion delay is $100\mu\text{s}$ at a clock frequency of 640 KHz, which is quite low as compared to other converters. These converters do not need any external zero or full scale adjustments as they are already taken care of by internal circuits. These converters internally have a 3:8 analog multiplexer so that at a time eight different analog conversion by using address lines -

ADD A, ADD B, ADD C. Using these address inputs, multichannel data acquisition system can be designed using a single ADC. The CPU may drive these lines using output port lines in case of multichannel applications. In case of single input applications, these may be hardwired to select the proper input.

- There are unipolar analog to digital converters, i.e. they are able to convert only positive analog input voltage to their digital equivalent. These chips do not contain any internal sample and hold circuit.

Analog /P selecte	Address lines		
	C	B	A
I / P ₀	0	0	0
I / P ₁	0	0	1
I / P ₂	0	1	0
I / P ₃	0	1	1
I / P ₄	1	0	0
I / P ₅	1	0	1
I / P ₆	1	1	0
I / P ₇	1	1	1

- If one needs a sample and hold circuit for the conversion of fast signal into equivalent digital quantities, it has to be externally connected at each of the analog inputs.
- V_{cc} Supply pins +5V
- GND GND
- V_{ref+} Reference voltage positive +5 Volts maximum.
- V_{ref-} Reference voltage negative 0Volts minimum.
- I/P₀ –I/P₇ Analog inputs
- ADD A,B,C Address lines for selecting analog inputs.
- O₇ – O₀ Digital 8-bit output with O₇ MSB and O₀ LSB
- SOC Start of conversion signal pin
- EOC End of conversion signal pin
- OE Output latch enable pin, if high enables output
- CLK Clock input for ADC



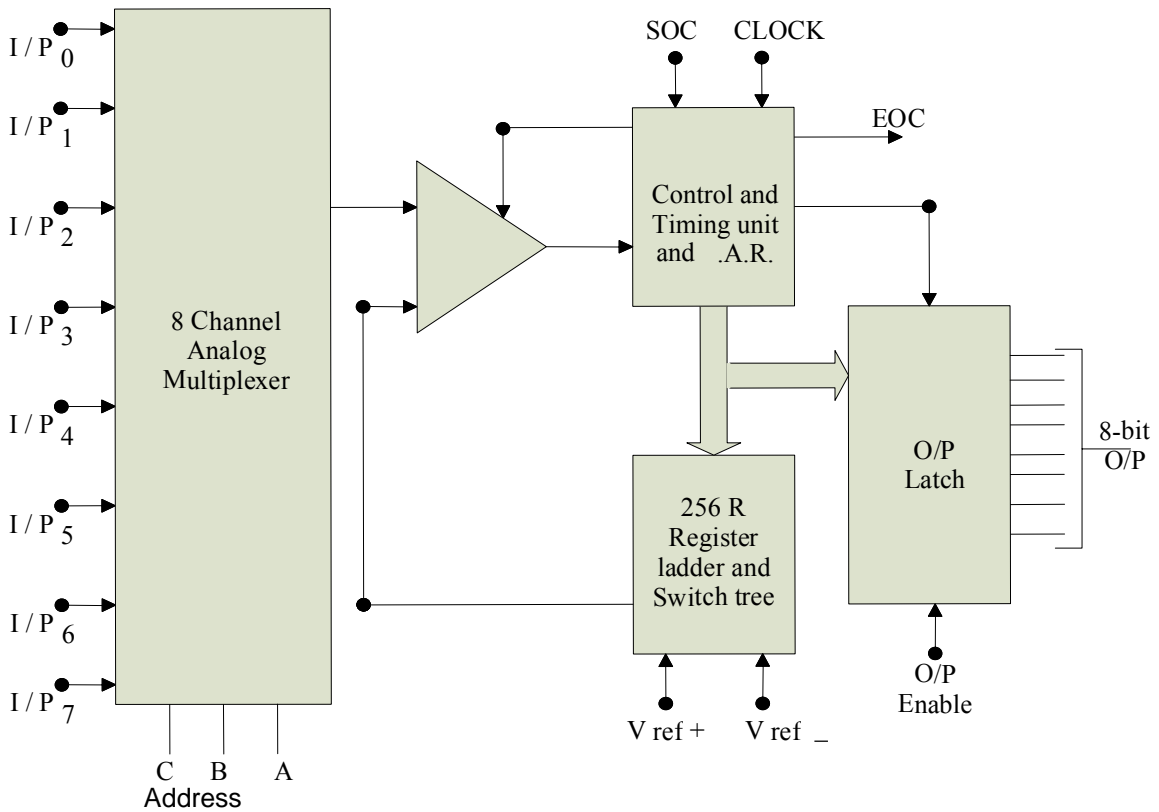

Block Diagram of ADC 0808 / 0809

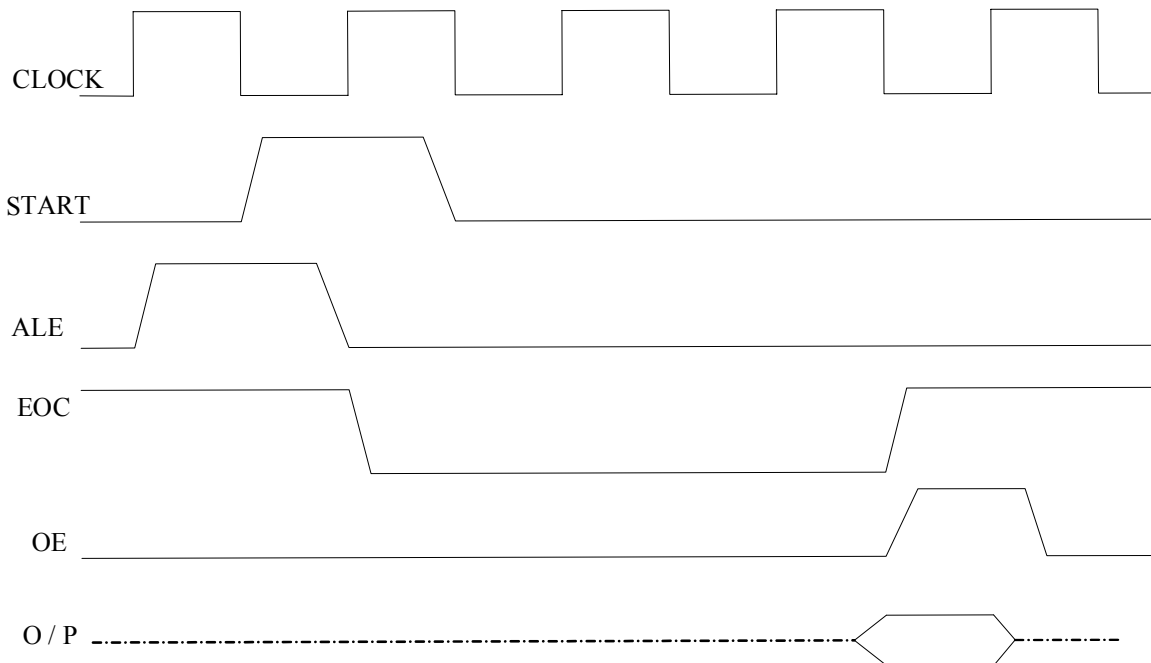

Timing Diagram of ADC 0808

- **Example:** Interfacing ADC 0808 with 8086 using 8255 ports. Use port A of 8255 for transferring digital data output of ADC to the CPU and port C for control

- signals. Assume that an analog input is present at I/P2 of the ADC and a clock input of suitable frequency is available for ADC.
- **Solution:** The analog input I/P2 is used and therefore address pins A,B,C should be 0,1,0 respectively to select I/P2. The OE and ALE pins are already kept at +5V to select the ADC and enable the outputs. Port C upper acts as the input port to receive the EOC signal while port C lower acts as the output port to send SOC to the ADC.
 - Port A acts as a 8-bit input data port to receive the digital data output from the ADC. The 8255 control word is written as follows:
D7 D6 D5 D4 D3 D2 D1 D0
1 0 0 1 1 0 0 0
 - The required ALP is as follows:
MOV AL, 98h ;initialise 8255 as
OUT CWR, AL ;discussed above.
MOV AL, 02h ;Select I/P2 as analog
OUT Port B, AL ;input.
MOV AL, 00h ;Give start of conversion
OUT Port C, AL ; pulse to the ADC
MOV AL, 01h
OUT Port C, AL
MOV AL, 00h
OUT Port C, AL
WAIT: IN AL, Port C ;Check for EOC by
RCR ; reading port C upper and
JNC WAIT ;rotating through carry.
IN AL, Port A ;If EOC, read digital equivalent in AL
HLT ;Stop.

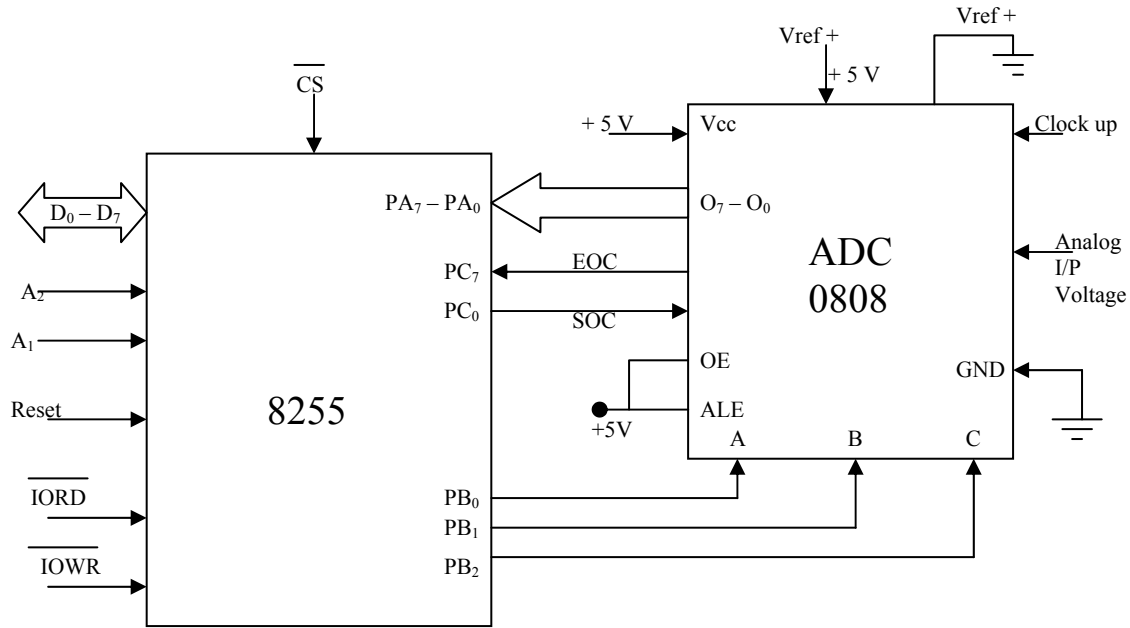

Interfacing 0808 with 8086

Interfacing Digital To Analog Converters

INTERFACING DIGITAL TO ANALOG CONVERTERS: The digital to analog converters convert binary number into their equivalent voltages. The DAC find applications in areas like digitally controlled gains, motors speed controls, programmable gain amplifiers etc.

AD 7523 8-bit Multiplying DAC : This is a 16 pin DIP, multiplying digital to analog converter, containing R-2R ladder for D-A conversion along with single pole double thrown NMOS switches to connect the digital inputs to the ladder.

- The pin diagram of AD 7523 shows 16 pins. Pin 1 is V_{ref}+, pin 2 is V_{ref}-, pin 3 is GND, pin 4 is B₂, pin 5 is B₁, pin 6 is B₀, pin 7 is B₇, pin 8 is B₆, pin 9 is B₅, pin 10 is B₄, pin 11 is B₃, pin 12 is B₂, pin 13 is B₁, pin 14 is B₀, pin 15 is V_{ref}+, and pin 16 is GND.
- Usually a zener is connected across the B₂ and B₁ pins to protect the converter at the output.
- It also offers an additional resistor to control the gain of the converter, if no gain control resistor is present.

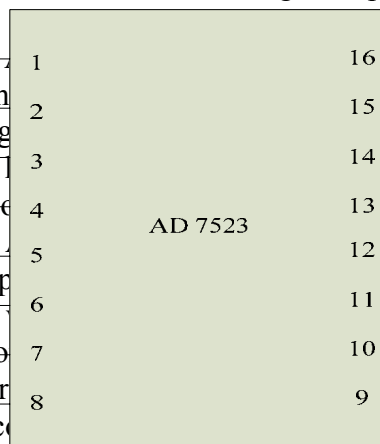

- The supply range is from +5V to +15V. The maximum analog output voltage is from -10V to +10V, when all the digital inputs are at logic 1.
- The maximum current drawn by the DAC from the supply is 10mA.
- The output of the DAC is a current output. An external feedback resistor is connected between the output and the B₆ pin to convert the current output to a voltage output.

- **EXAMPLE:** Interfacing DAC AD7523 with an 8086 CPU running at 8MHZ and write an assembly language program to generate a sawtooth waveform of period 1ms with V_{max} 5V.

Pin Diagram of AD 7523

- **Solution:** Fig shows the interfacing circuit of AD 74523 with 8086 using 8255. The program gives an ALP to generate a sawtooth waveform using circuit.

```

ASSUME    CS:CODE
CODE SEGMENT
START     :MOV AL,80h      ;make all ports output
          OUT  CW, AL
AGAIN    :MOV AL,00h      ;start voltage for ramp
BACK :   OUT  PA, AL
          INC  AL
          CMP  AL, 0FFh
          JB   BACK
          JMP  AGAIN
CODE ENDS
END       START

```

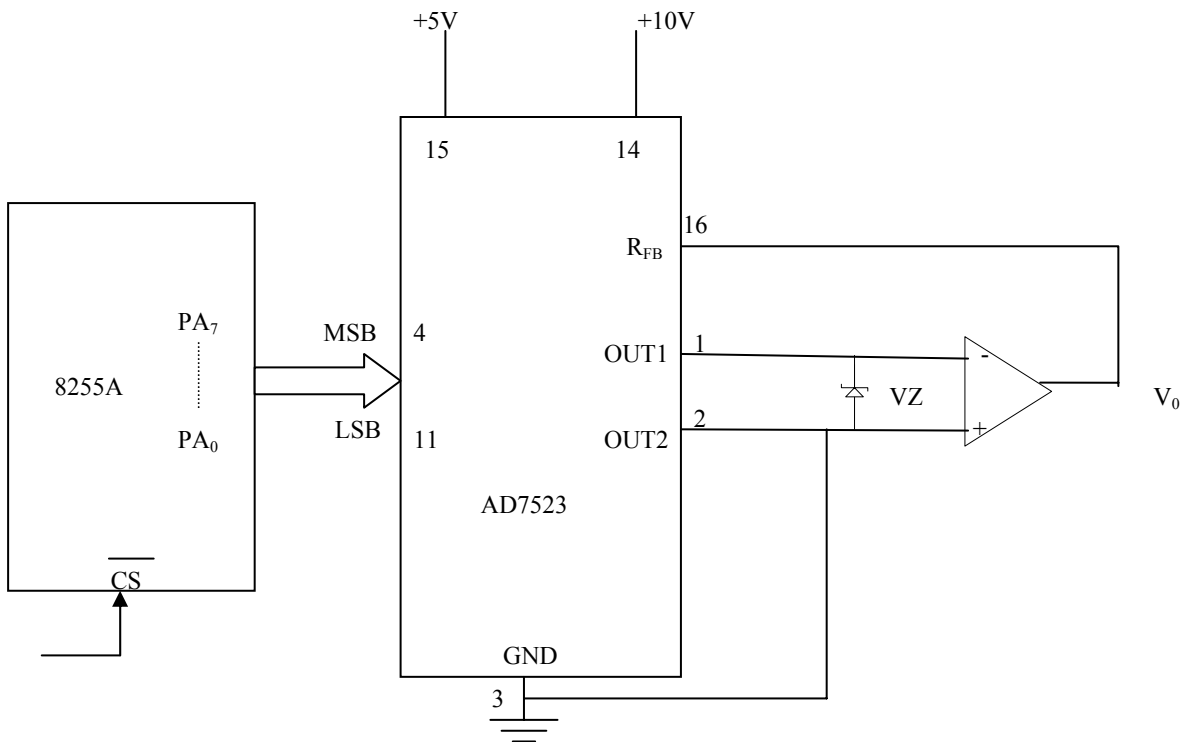

Fig: Interfacing of AD7523

- In the above program, port A is initialized as the output port for sending the digital data as input to DAC. The ramp starts from the 0V (analog), hence AL starts with 00H. To increment the ramp, the content of AL is increased during each execution of loop till it reaches F2H.
- After that the saw tooth wave again starts from 00H, i.e. 0V(analog) and the procedure is repeated. The ramp period given by this program is precisely 1.000625 ms. Here the count F2H has been calculated by dividing the required delay of 1ms by the time required for the execution of the loop once. The ramp slope can be controlled by calling a controllable delay after the OUT instruction.