

CLUTCH

Clutch Introduction

A *Clutch* is a machine member used to connect the driving shaft to a driven shaft, so that the driven shaft may be started or stopped at will, without stopping the driving shaft. A clutch thus provides an interruptible connection between two rotating shafts

Clutches allow a high inertia load to be started with a small power.

A popularly known application of clutch is in automotive vehicles where it is used to connect the engine and the gear box. Here the clutch enables to crank and start the engine disengaging the transmission. Disengage the transmission and change the gear to alter the torque on the wheels. Clutches are also used extensively in production machinery of all types

Mechanical Model

Two inertia's I_1 and I_2 and traveling at the respective angular velocities ω_1 and ω_2 , and one of which may be zero, are to be brought to the same speed by engaging. Slippage occurs because the two elements are running at different speeds and energy is dissipated during actuation, resulting in temperature rise.

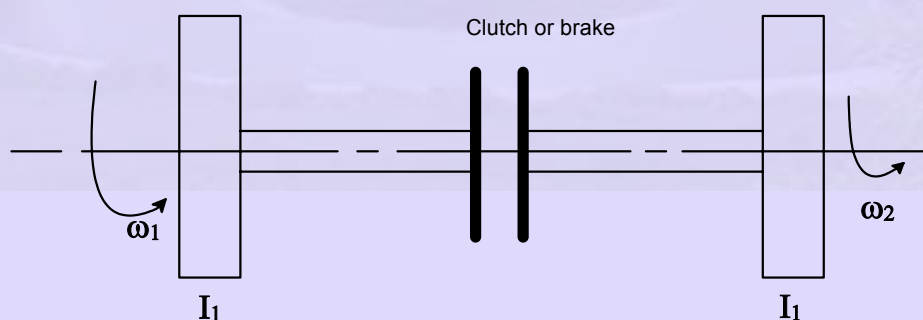

Dynamic Representation of Clutch or Brake

Figure 3.2.1

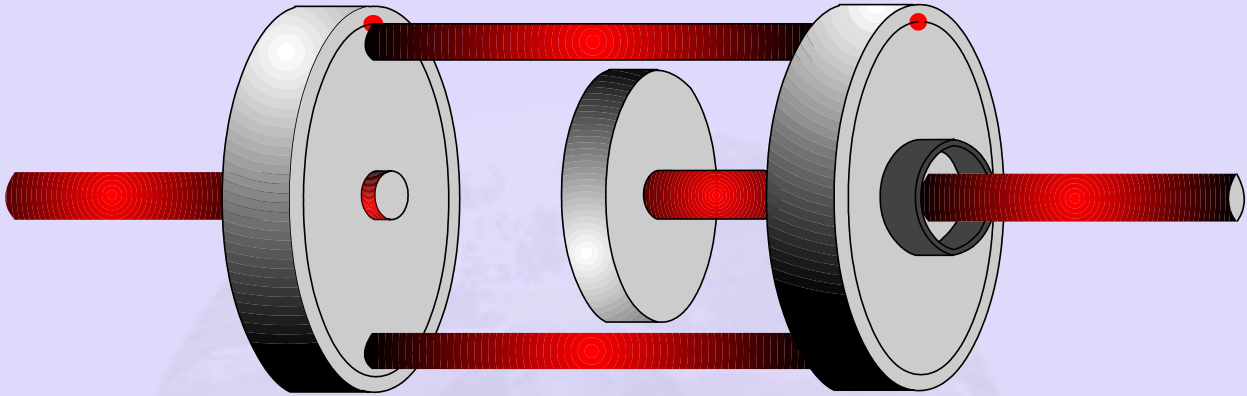

Animated

Figure 3.2.2

To design analyze the performance of these devices, a knowledge on the following are required.

1. *The torque transmitted*
2. *The actuating force.*
3. *The energy loss*
4. *The temperature rise*

FRICION CLUTCHES

As in brakes a wide range of clutches are in use wherein they vary in their are in use their working principle as well the method of actuation and application of normal forces. The discussion here will be limited to mechanical type friction

clutches or more specifically to the plate or disc clutches also known as axial clutches

Frictional Contact axial or Disc Clutches

An axial clutch is one in which the mating frictional members are moved in a direction parallel to the shaft. A typical clutch is illustrated in the figure below. It consist of a driving disc connected to the drive shaft and a driven disc co9nected to the driven shaft. A friction plate is attached to one of the members. Actuating spring keeps both the members in contact and power/motion is transmitted from one member to the other. When the power of motion is to be interrupted the driven disc is moved axially creating a gap between the members as shown in the figure.

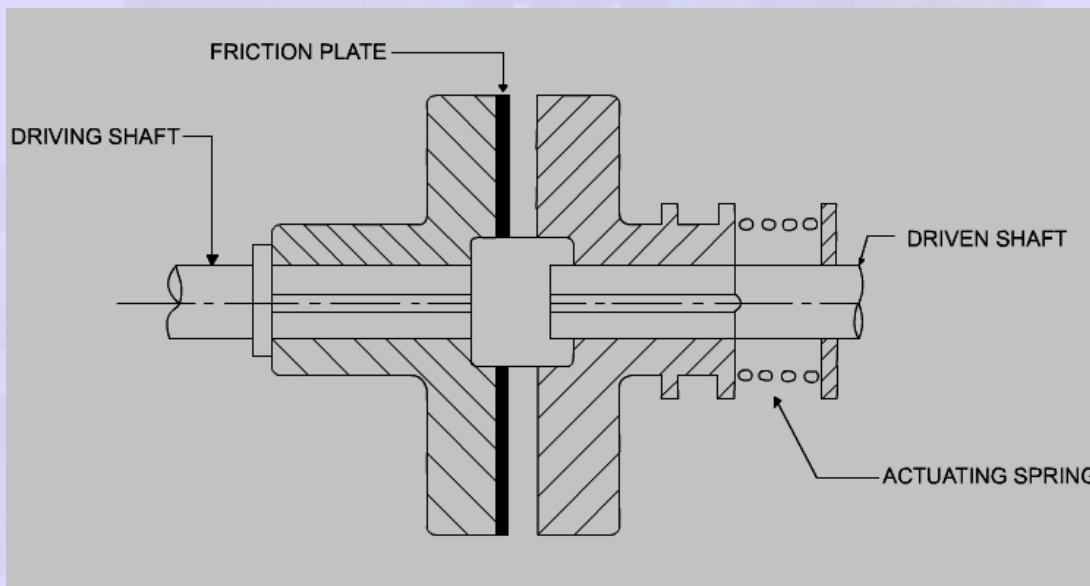
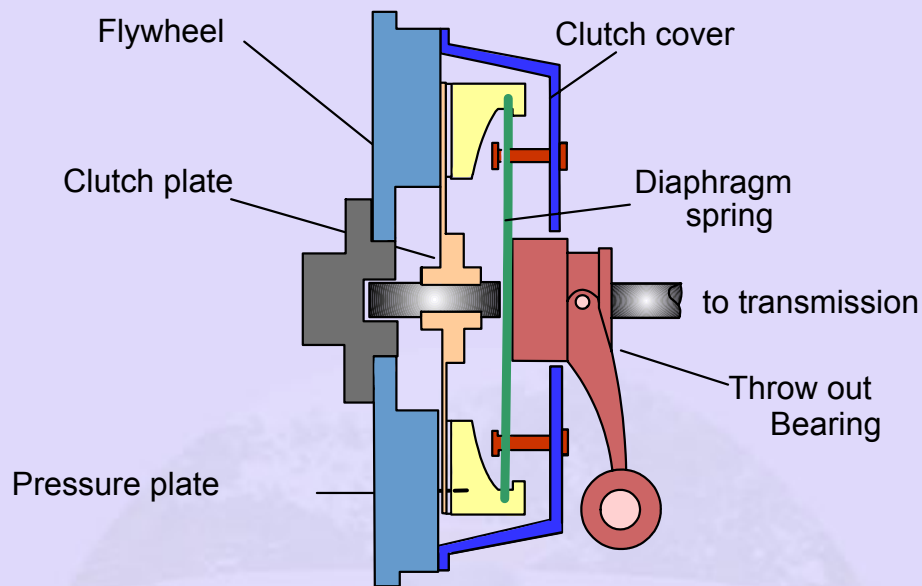

Figure 3.2.3



Animated

Figure 3.2.4

METHOD OF ANALYSIS

The torque that can be transmitted by a clutch is a function of its geometry and the magnitude of the actuating force applied as well the condition of contact prevailing between the members. The applied force can keep the members together with a uniform pressure all over its contact area and the consequent analysis is based on uniform pressure condition

Uniform Pressure and wear

However as the time progresses some wear takes place between the contacting members and this may alter or vary the contact pressure appropriately and uniform pressure condition may no longer prevail. Hence the analysis here is based on uniform wear condition

Elementary Analysis

Assuming uniform pressure and considering an elemental area dA

$$dA = 2\pi.r dr$$

The normal force on this elemental area is

$$dN = 2\pi.r.dr.p$$

The frictional force dF on this area is therefore

$$dF = f.2\pi.r.dr.p$$



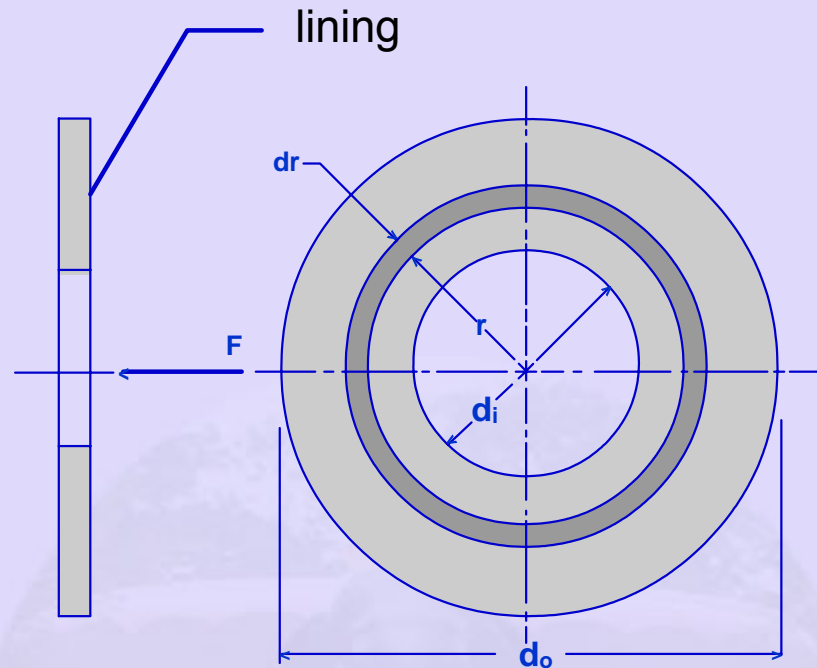

A single-Surface Axial Disk Clutch

Figure 3.2.5

Now the torque that can be transmitted by this elemental area is equal to the frictional force times the moment arm about the axis that is the radius 'r'

$$\begin{aligned} \text{i.e. } T &= dF \cdot r = f \cdot dN \cdot r = f \cdot p \cdot A \cdot r \\ &= f \cdot p \cdot 2 \cdot \pi \cdot r \cdot dr \cdot r \end{aligned}$$

The total torque that could be transmitted is obtained by integrating this equation between the limits of inner radius r_i to the outer radius r_o

$$T = \int_{r_i}^{r_o} 2\pi p f r^2 dr = \frac{2}{3} \pi p f (r_o^3 - r_i^3)$$

Integrating the normal force between the same limits we get the actuating force that need to be applied to transmit this torque.

$$F_a = \int_{r_i}^{r_o} 2\pi p r dr$$

$$F_a = \pi (r_o^2 - r_i^2) \cdot p$$

Equation 1 and 2 can be combined together to give equation for the torque

$$T = fF_a \cdot \frac{2}{3} \frac{(r_o^3 - r_i^3)}{(r_o^2 - r_i^2)}$$

Uniform Wear Condition

According to some established theories the wear in a mechanical system is proportional to the 'PV' factor where P refers the contact pressure and V the sliding velocity. Based on this for the case of a plate clutch we can state

The constant-wear rate R_w is assumed to be proportional to the product of pressure p and velocity V .

$$R_w = pV = \text{constant}$$

And the velocity at any point on the face of the clutch is $V = r \cdot \omega$

Combining these equation, assuming a constant angular velocity ω

$$pr = \text{constant} = K$$

The largest pressure p_{\max} must then occur at the smallest radius r_i ,

$$K = p_{\max} r_i$$

Hence pressure at any point in the contact region

$$p = p_{\max} \frac{r_i}{r}$$

In the previous equations substituting this value for the pressure term p and integrating between the limits as done earlier we get the equation for the torque transmitted and the actuating force to be applied.

I.e The axial force F_a is found by substituting $p = p_{\max} \frac{r_i}{r}$ for p .

and integrating equation $dN = 2\pi p r dr$

$$F = \int_{r_i}^{r_o} 2\pi p r dr = \int_{r_i}^{r_o} 2\pi \left(p_{\max} \frac{r_i}{r} \right) r dr = 2\pi p_{\max} r_i (r_o - r_i)$$

Similarly the Torque

$$T = \int_{r_i}^{r_o} f 2\pi p_{\max} r_i r dr = f\pi p_{\max} r_i (r_o^2 - r_i^2)$$

Substituting the values of actuating force F_a

The equation can be given as

$$T = fF_a \cdot \frac{(r_o + r_i)}{2}$$

Single plate dry Clutch – Automotive application

The clutch used in automotive applications is generally a single plate dry clutch. In this type the clutch plate is interposed between the flywheel surface of the engine and pressure plate.

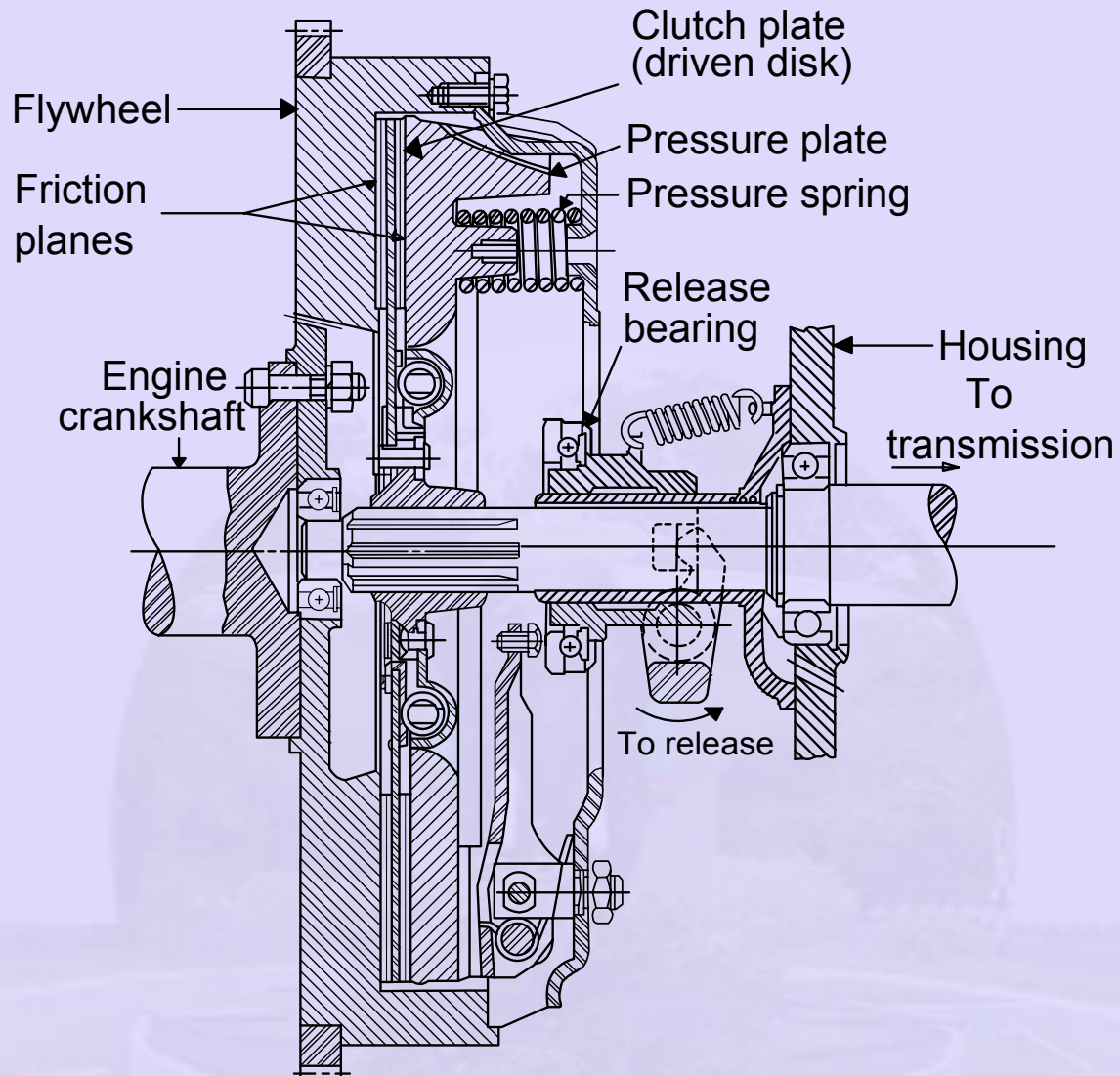

Figure 3.2.6

Single Clutch and Multiple Disk Clutch

Basically, the clutch needs three parts. These are the engine flywheel, a friction disc called the clutch plate and a pressure plate. When the engine is running and the flywheel is rotating, the pressure plate also rotates as the pressure plate is attached to the flywheel. The friction disc is located between the two. When

the driver has pushed down the clutch pedal the clutch is released. This action forces the pressure plate to move away from the friction disc. There are now air gaps between the flywheel and the friction disc, and between the friction disc and the pressure plate. No power can be transmitted through the clutch.

Operation Of Clutch

When the driver releases the clutch pedal, power can flow through the clutch. Springs in the clutch force the pressure plate against the friction disc. This action clamps the friction disk tightly between the flywheel and the pressure plate. Now, the pressure plate and friction disc rotate with the flywheel.

As both side surfaces of the clutch plate is used for transmitting the torque, a term 'N' is added to include the number of surfaces used for transmitting the torque

By rearranging the terms the equations can be modified and a more general form of the equation can be written as

$$T = N \cdot f \cdot F_a \cdot R_m$$

T is the torque (Nm).

N is the number of frictional discs in contact.

f is the coefficient of friction

F_a is the actuating force (N).

R_m is the mean or equivalent radius (m).

Note that $N = n_1 + n_2 - 1$

Where n_1 = number of driving discs

n_2 = number of driven discs

Values of the actuating force F and the mean radius r_m for the two conditions of analysis are summarized and shown in the table

Clutch Construction

Two basic types of clutch are the coil-spring clutch and the diaphragm-spring clutch. The difference between them is in the type of spring used. The coil spring clutch shown in left Fig 3.2.6 uses coil springs as pressure springs (only two pressure spring is shown). The clutch shown in right figure 3.2.6 uses a diaphragm spring.

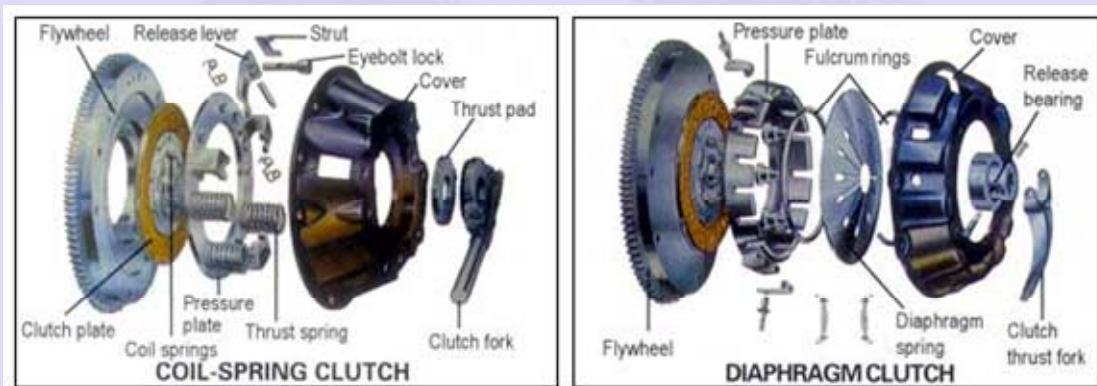

Figure 3.2.6

The coil-spring clutch has a series of coil springs set in a circle.

At high rotational speeds, problems can arise with multi coil spring clutches owing to the effects of centrifugal forces both on the spring themselves and the lever of the release mechanism.

These problems are obviated when diaphragm type springs are used, and a number of other advantages are also experienced

Clutch or Driven Plate

More complex arrangements are used on the driven or clutch plate to facilitate smooth function of the clutch

The friction disc, more generally known as the clutch plate, is shown partly cut away in Fig. It consists of a hub and a plate, with facings attached to the plate.

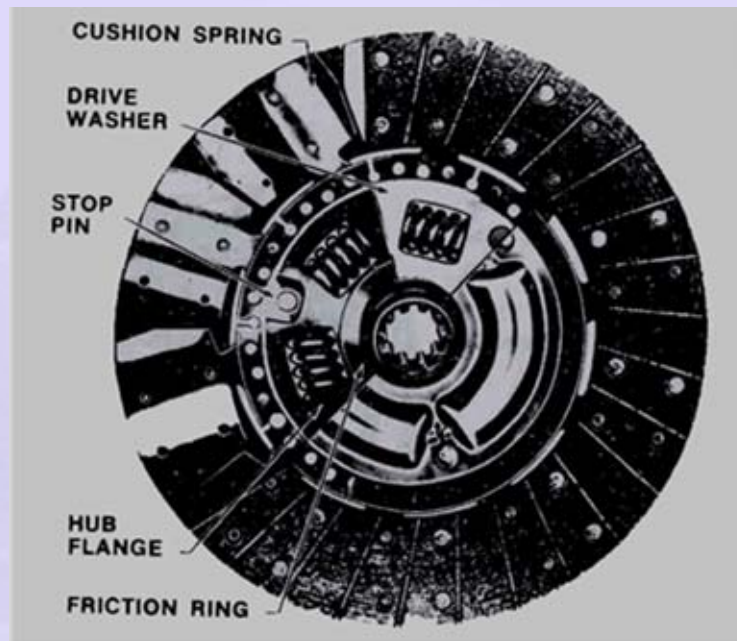

Figure 3.2.7

First to ensure that the drive is taken up progressively, the centre plate, on which the friction facings are mounted, consists of a series of cushion springs which is crimped radially so that as the clamping force is applied to the facings the crimping is progressively squeezed flat, enabling gradual transfer of the force

On the release of the clamping force, the plate springs back to its original position crimped (wavy) state

This plate is also slotted so that the heat generated does not cause distortion that would be liable to occur if it were a plain plate. This plate is of course thin to keep rotational inertia to a minimum.

Plate to hub Connection

Secondly the plate and its hub are entirely separate components, the drive being transmitted from one to the other through coil springs interposed between them. These springs are carried within rectangular holes or slots in the hub and plate and arranged with their axes aligned appropriately for transmitting the drive. These dampening springs are heavy coil springs set in a circle around the hub. The hub is driven through these springs. They help to smooth out the torsional vibration (the power pulses from the engine) so that the power flow to the transmission is smooth.

In a simple design all the springs may be identical, but in more sophisticated designs they are arranged in pairs located diametrically opposite, each pair having a different rate and different end clearances so that their role is progressive providing increasing spring rate to cater to wider torsional damping

The clutch plate is assembled on a splined shaft that carries the rotary motion to the transmission. This shaft is called the clutch shaft, or transmission input shaft.

This shaft is connected to the gear box or forms a part of the gear box.

Friction Facings or Pads

It is the friction pads or facings which actually transmit the power from the fly wheel to hub in the clutch plate and from there to the output shaft. There are

grooves in both sides of the friction-disc facings. These grooves prevent the facings from sticking to the flywheel face and pressure plate when the clutch is disengaged. The grooves break any vacuum that might form and cause the facings to stick to the flywheel or pressure plate. The facings on many friction discs are made of cotton and asbestos fibers woven or molded together and impregnated with resins or other binding agents. In many friction discs, copper wires are woven or pressed into the facings to give them added strength. However, asbestos is being replaced with other materials in many clutches. Some friction discs have ceramic-metallic facings.

Such discs are widely used in multiple plate clutches

To minimize the wear problems, all the plates will be enclosed in a covered chamber and immersed in an oil medium

Such clutches are called wet clutches

Multiple Plate Clutches

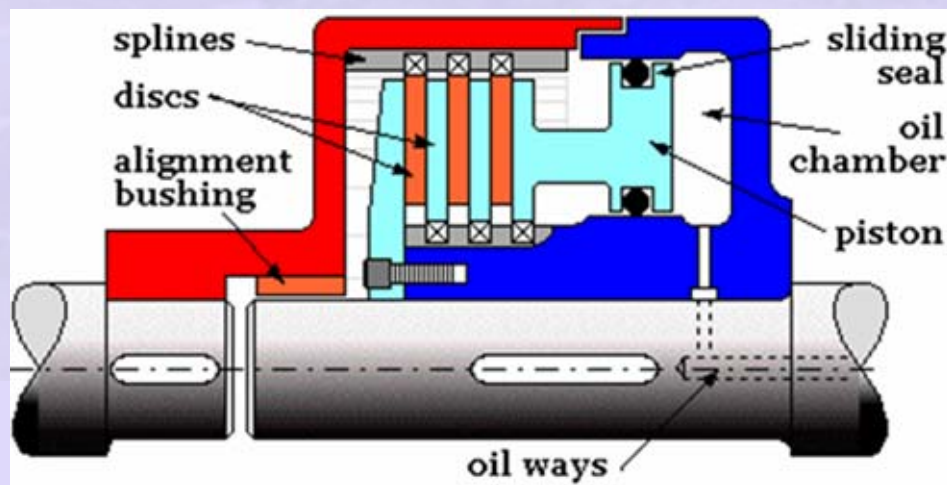

Figure 3.2.8

The properties of the frictional lining are important factors in the design of the clutches

Typical characteristics of some widely used friction linings are given in the table

Table Properties of common clutch/ Brake lining materials				
Friction Material Against Steel or CI	Dynamic Coefficient of Friction		Maximum Pressure KPa	Maximum Temperature °C
	dry	in oil		
Molded	0.25-0.45	0.06-0.09	1030-2070	204-260
Woven	0.25-0.45	0.08-0.10	345-690	204-260
Sintered metal	0.15-0.45	0.05-0.08	1030-2070	232-677
Cast iron or hard steel	0.15-0.25	0.03-0.06	690-720	260

Table 3.2.1

