



Jet Aircraft Propulsion

Prof. Bhaskar Roy, Prof. A M Pradeep

Department of Aerospace Engineering,
IIT Bombay

Lecture 24

Combustion Chambers

Combustion Mechanism

- Heat addition by combustion is conceived as a part of the working Brayton cycle.
- In this process energy is put into the system by burning fuel in a flowing gas.
- In aircraft gas turbine engines the air flow through the engine is at high average speed (100 m/s), which requires high combustion intensity (***heat release rate per unit volume per unit time***).
- Also, in aircraft powerplant size of the engine being limited, the space available for combustion process is also limited.
- Thus the combustion is to be performed within a very small volume, at a short time (air flow residence time) giving out high amount of heat.

The combustion intensities of some heat engine combustion processes are compared:

Boiler furnaces	-----	4×10^5 to 10^6 kJ/m ³ .hr (1×10^2 to 10^3 kWatts/m ³)
Piston engine	-----	$25 - 125 \times 10^5$ to 10^6 kJ/m ³ .hr ($7 - 35 \times 10^2$ to 10^3 kWatts/m ³)
Jet engine	-----	$75 - 150 \times 10^5$ to 10^6 kJ/m ³ .hr ($21 - 42 \times 10^2$ to 10^3 kWatts/m ³)
Rocket engine	-----	260×10^5 to 10^6 kJ/m ³ .hr (72×10^2 to 10^3 kWatts/m ³)

- The condition at the burner inlet is determined by the outlet operating conditions of the compressor.
- This may keep varying with varying flight regimes.
- On the other hand, the outlet condition is governed by turbine design operating limits and is generally required to be uniform and stable.
- Hence, combustion chamber is expected to be a stable source of hot gas. That means even if its inlet conditions are variable it is expected to deliver comparatively steady and uniform flow to the turbine

The job of a combustor can be laid down as:

- *To raise the temperature of air to the highest level conforming to cycle design.*
- *This is intended to achieve maximum work extracted per kg of air flowing through the turbine.*
- *This must be done with minimum loss of pressure.*
- *The hot gases must be delivered at uniform pressure and temperature, within material limitations of turbine*

- *The hot gas generation must be stable during engine acceleration and deceleration i.e. flame should not be extinguished or pulsations should not be set up or amplified by combustion chamber.*
- *Ignition should be rapid, reliable and sustainable*
- *It should occupy minimum space*
- *It should burn a range of fuels.*

Individual Can Type combustion chamber

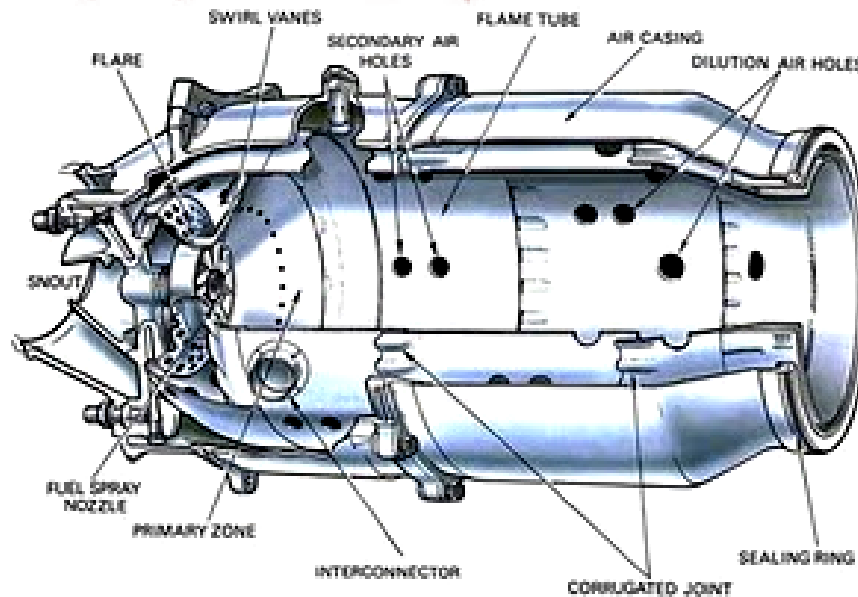
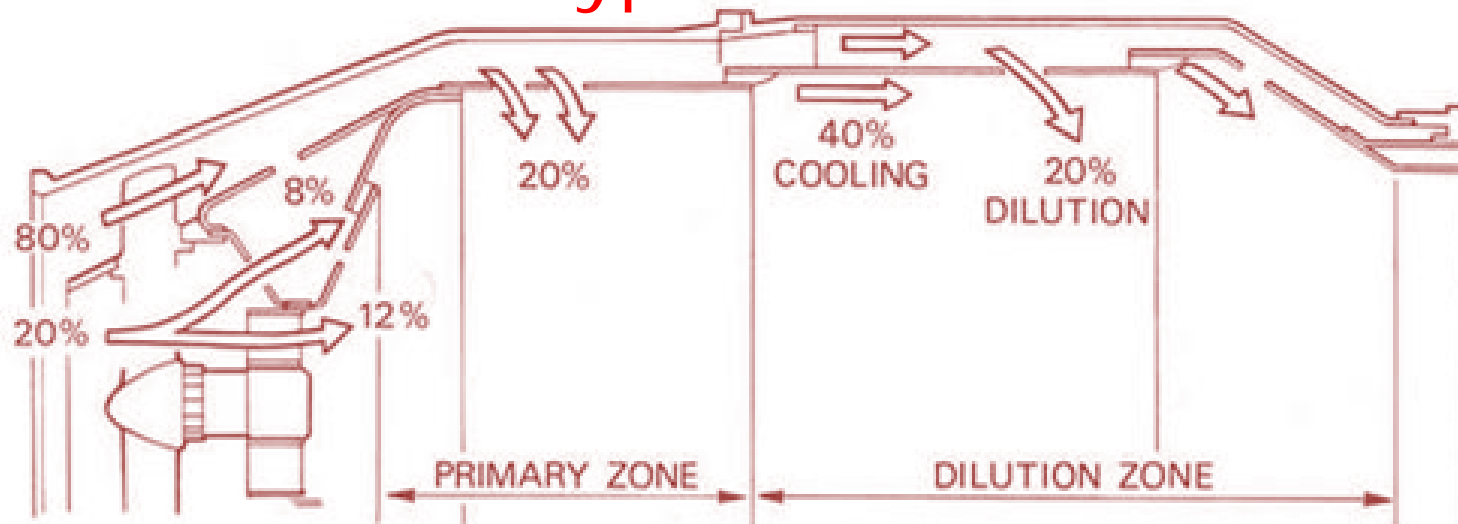

Cannular Type Combustion Chambers

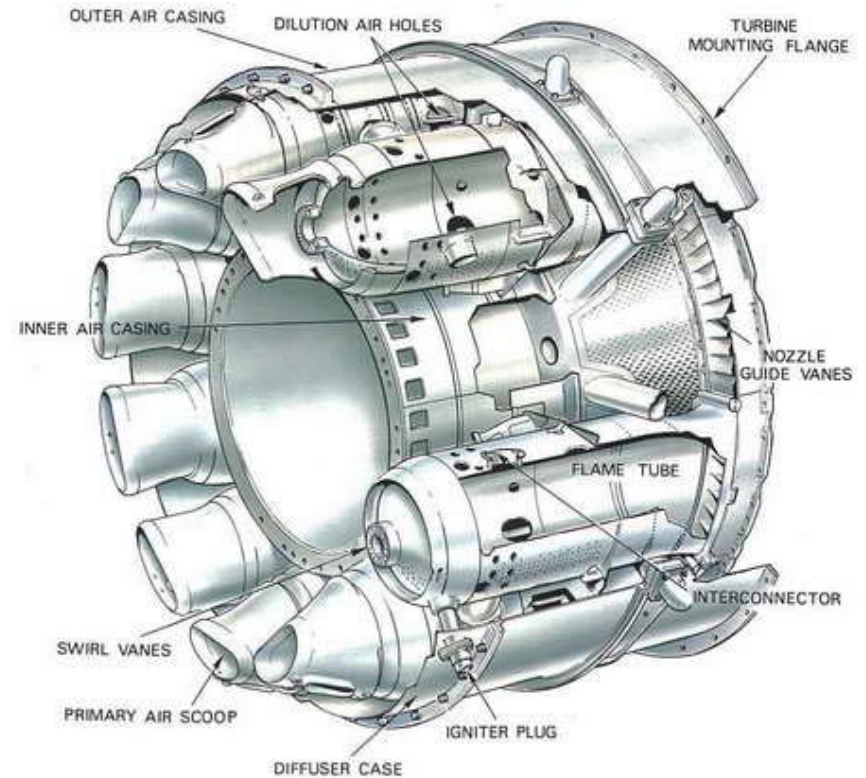
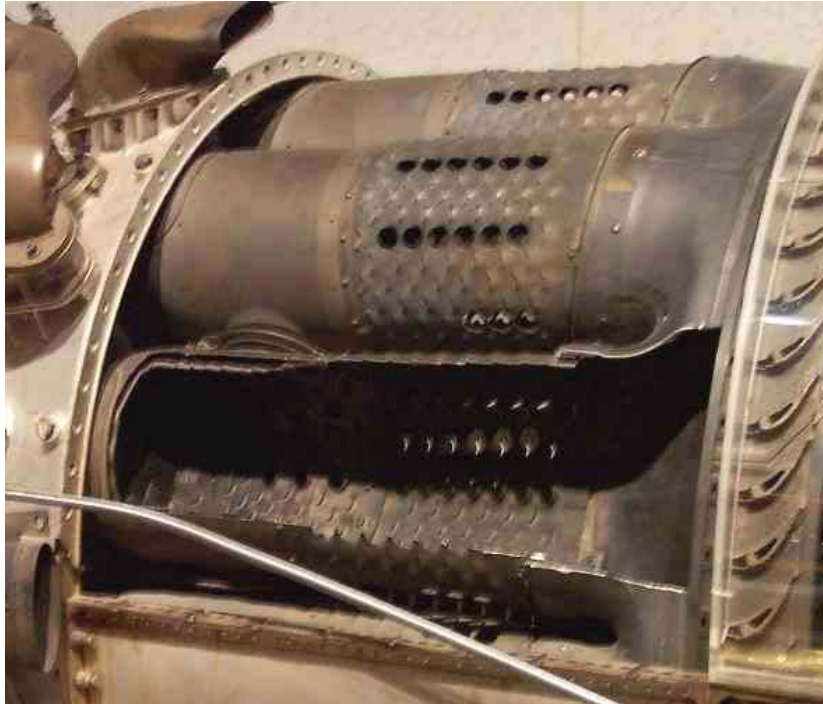

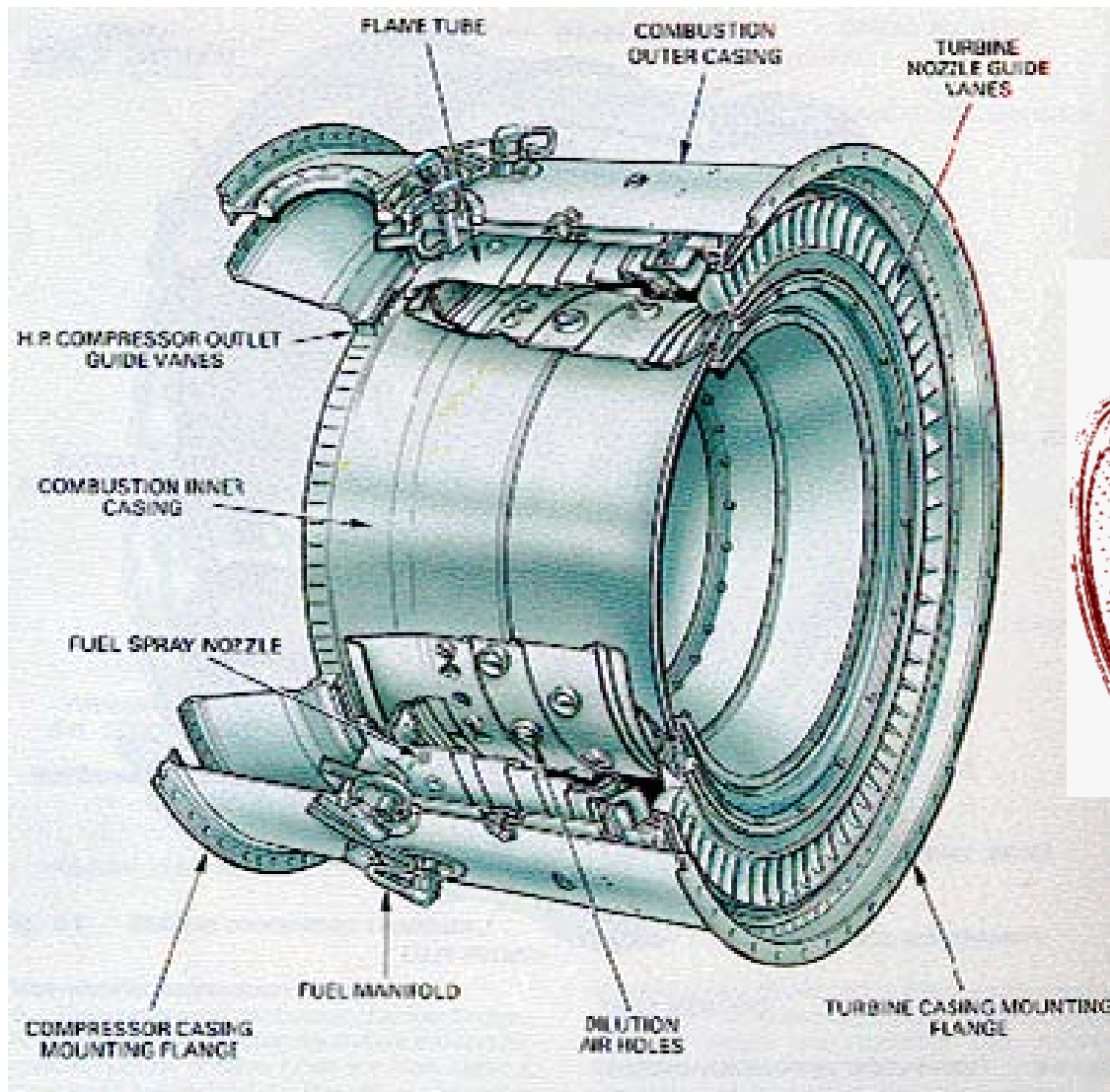

Annular Combustion Chamber

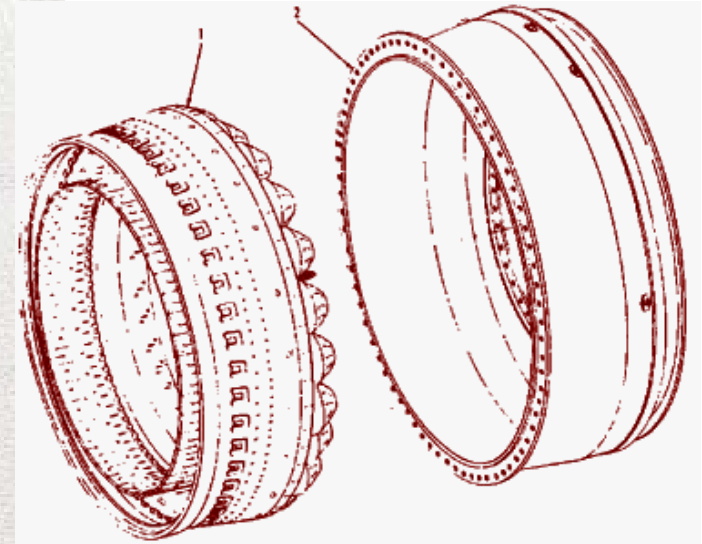

Combustion model for a gas turbine combustor

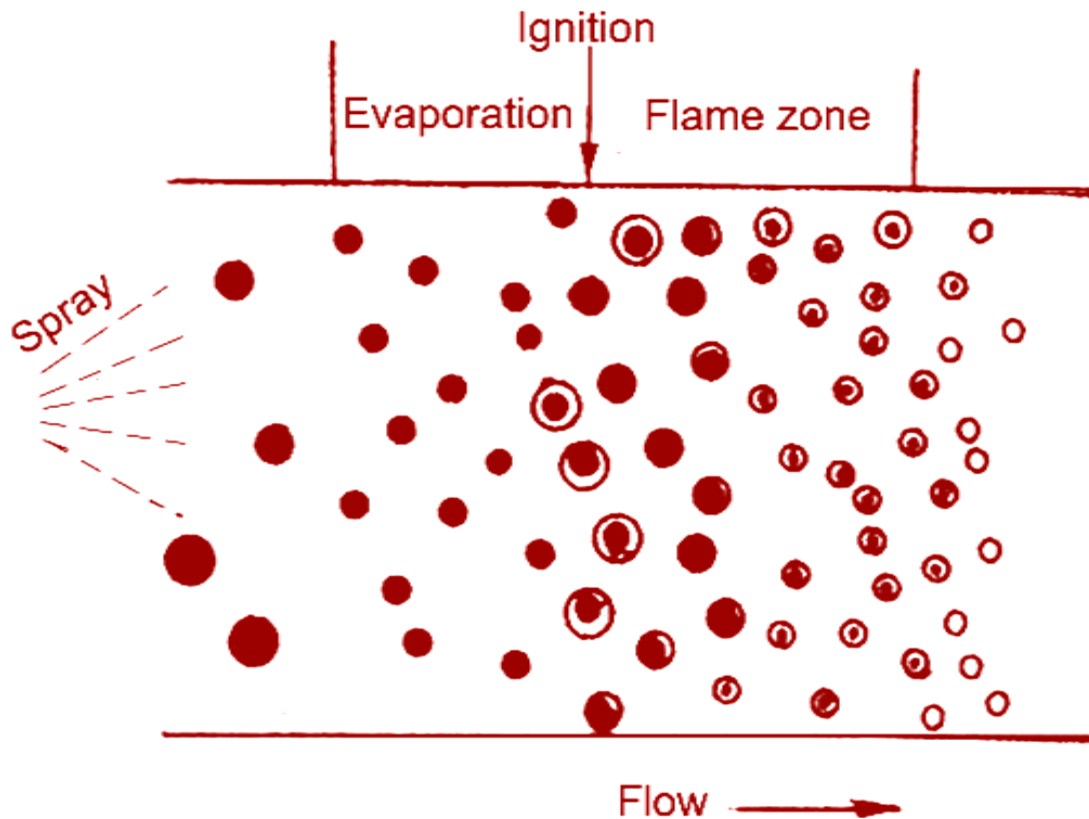

Steps :

- 1) Spray through an Injector
- 2) Atomization
- 3) Evaporation
- 4) Mixing with air
- 5) Ignition
- 6) Heat release
- 7) Mixing of combustion products
- 8) Delivery to Turbine

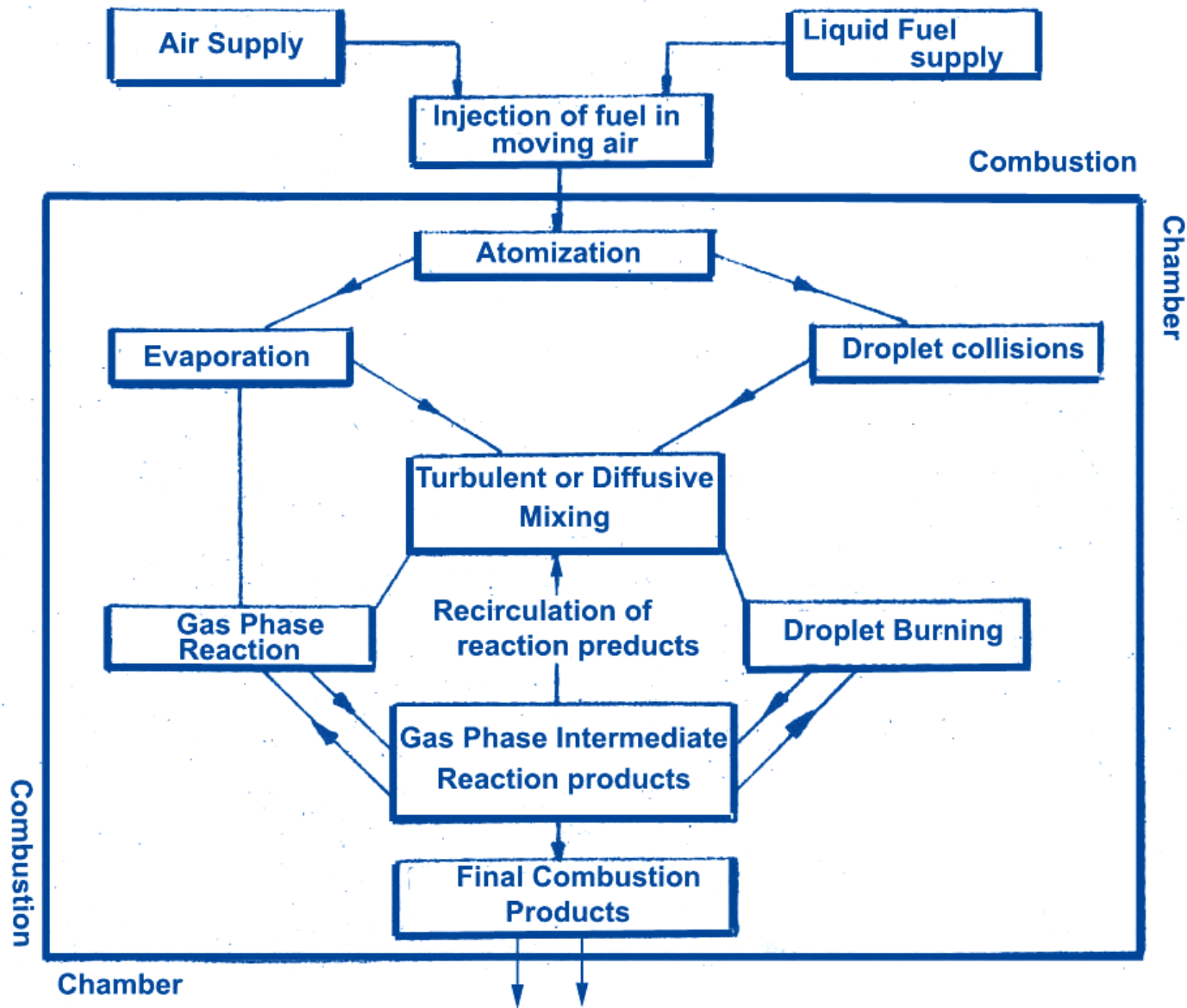

- The flame moves in the direction of the air flow inside the combustion chamber at a characteristic speed known as flame speed. The flame is sustained in a flame zone at the end of which most of fuel is burned. Outside the flame zone the combusted gas moves towards the combustor exit.
- The process of evaporation of droplets and mixing of fuel and air can occur partly aided by local turbulent vortices artificially created around the spray zone, and partly by diffusion of liquid vapor into air.
- At the point of ignition all the droplets may not have been evaporated and mixed - hence some of them may burn as liquid droplets in a surrounding air.

- Both the processes of burning follow approximately the same of chemical reactions as per the reaction kinetics.
- The combustion process for the whole amount of injected fuel may not be completed at the end of flame zone, which creates the intermediate reaction products.
- As more air is mixed to bring down the temperature, in some places the reaction of combustion may be going on, while in the some other places the reaction proceeds for the final combustion products.

- Thus in a combustion chamber it is necessary to provide sufficient space for all of these steps of to be completed.
- As the resident period of air in the chamber is small fraction of a second, matching the physical steps with the reaction kinetics is crucial to efficient combustion process
- Above 2200°C air may be dissociated locally.

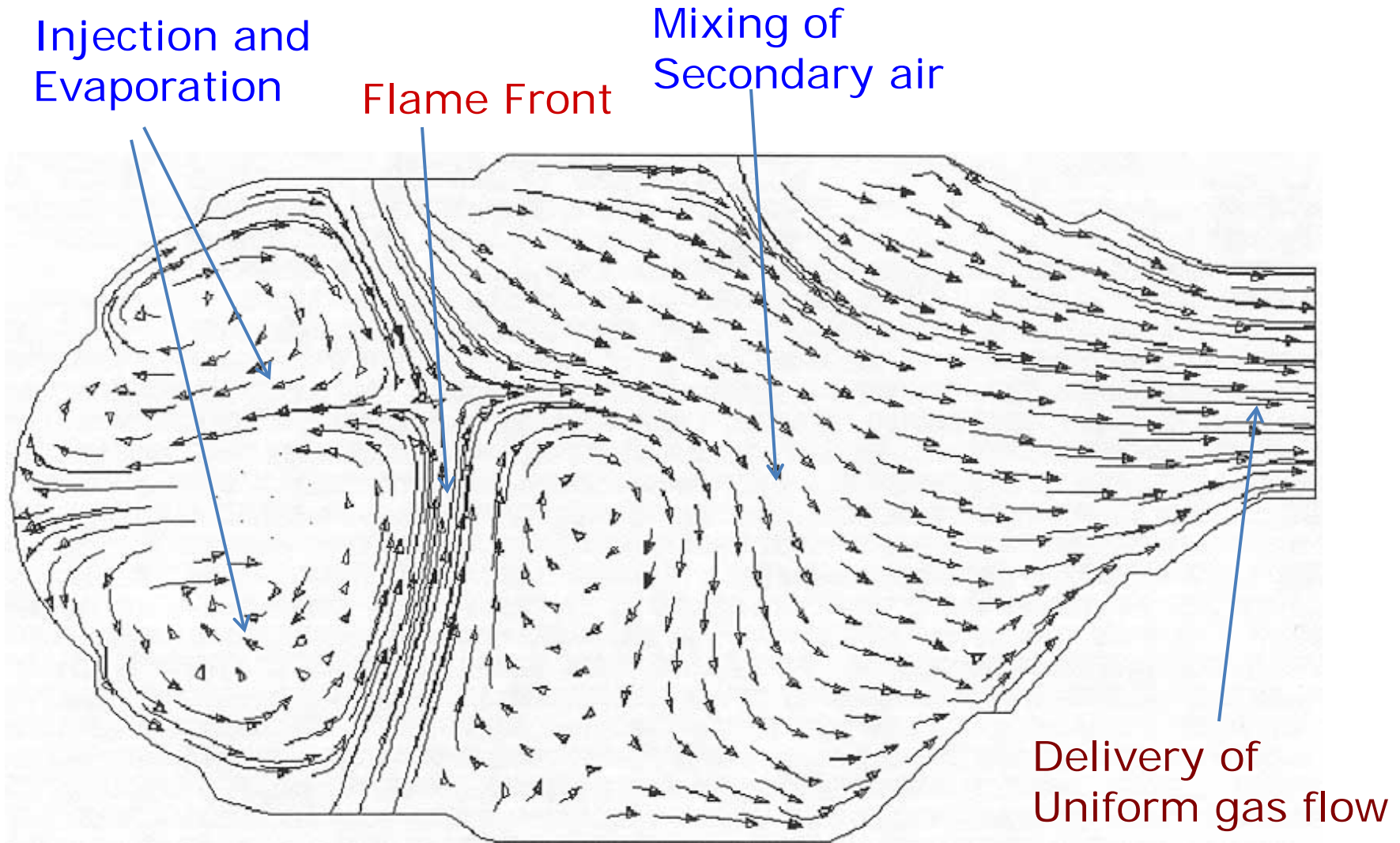

Limiting flame speed

- The speed of propagation of a flame through a mixture of hydrocarbon fuel and air is rather low.
- The “**flame speed**” will vary with the mixture strength, temperature and pressure.
- For laminar flow of air it is around 2 to 4 m/s.
- But, the average air velocity through a typical combustion chamber is around 30 – 50 m/s.
- Thus a region with low average local axial velocities must be provided if the flame is to be stabilized, sustained and contained in one place.

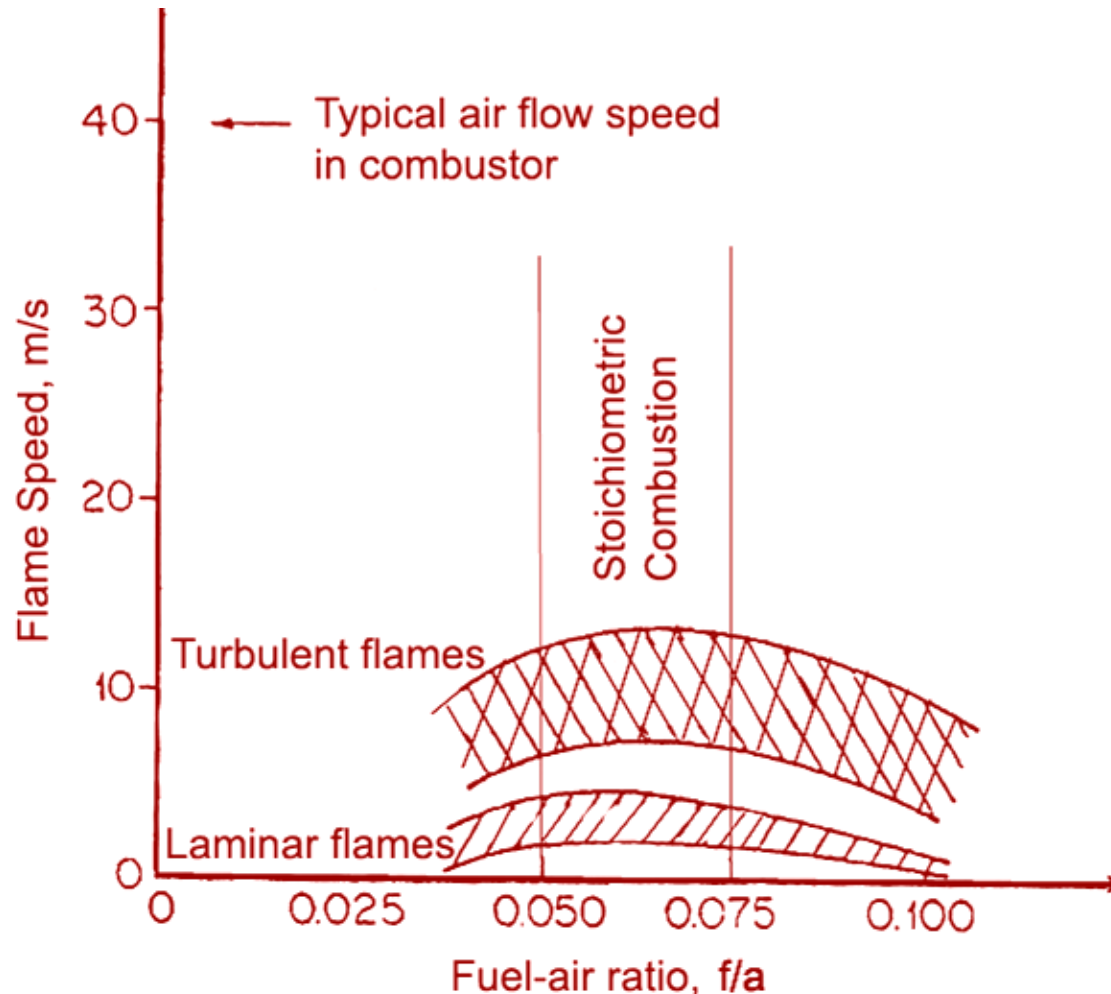

- The flame speed is higher for turbulent flows and much lower for laminar flows.
- In laminar flows maximum flame speed occurs at the lower fuel/air mixtures within Stoichiometric mixture limits.

- Stable burning of hydrocarbon fuels takes place close on either side of the stoichiometric value of fuel/air ratio.
- It is necessary to ensure that the mixture strength in the sheltered region is close to this stoichiometric value.
- The range of stable operation vary with total pressure in the comb. chamber, which decreases with increasing altitude till cruise flight is reached.
- In defining stability limits define a term called **Equivalence ratio** ϕ_{cc} defined as, is used :

$$\phi_{cc} = \frac{(f/a)_{\text{operative}}}{(f/a)_{\text{stoichiometric}}}$$

Property ↓ Fuel →	Basic Aviation Kerosene (JP-1)	JP-4/ Jet B (Military)	JP-5 (Safe fuel)	Jet A Commercial
Hydrogen/ Carbon	1.93	2.02	1.92	1.94
Initial boiling point, °C	50	60	180	170
End Point, °C	260	246	260	265
Flash Point, °C	49	-25 (37)*	65	52
Freezing Point °C	-60	-60	-50	-40
Heating Value, kJ/kg	43,200	43,400	43,000	43,400
Density kg/m ³ @ 15°C	800	760	820	810
Sp. Gravity (max.)	0.85	0.802 (0.84)*	0.871	0.860
Stoichiometric air/ fuel mass ratio	14.72	14.85	14.71	14.74

Next Class

Aerodynamic Pressure Losses
Combustion Efficiency
Combustion Intensity