

LECTURE 40 – MULTI ACTUATOR CIRCUITS

SELF EVALUATION QUESTIONS AND ANSWERS

1. Square shaped work has to be drilled using a drilling machine which is pneumatically operated. Work pieces are fed from a gravity magazine to a drilling machine. These work pieces are pushed and clamped by means of clamping cylinder 1.0 (A). hole is drilled by the drilling cylinder 2.0 (B). and work piece is ejected by ejecting cylinder 3.0 (C). The displacement step diagram is shown in Figure1 . The sequence of operation has to be carried out either for one cycle or for continuous cycle with start and stop controls. Develop a pneumatic circuit to implement the given control task.

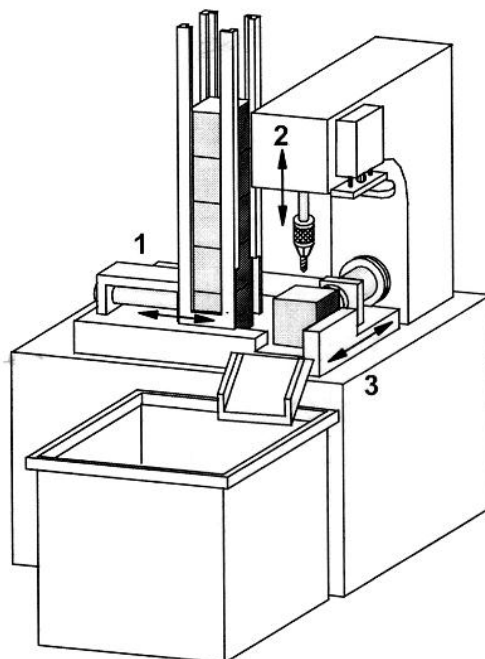
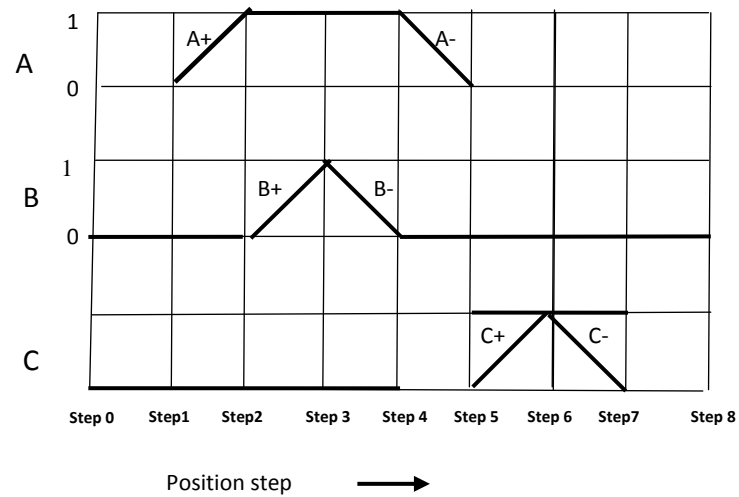

2 Two clips are to be riveted together on a semi automatic press. Components and rivets are positioned by hand and then removed by hand on completion of the components operation. The automated part of the working cycle consists of the holding and clamping of the components (cylinder A) and also the riveting (cylinder B), and the cycle be performed ending at the starting position after operating a start button.

Design circuit using cascade method.

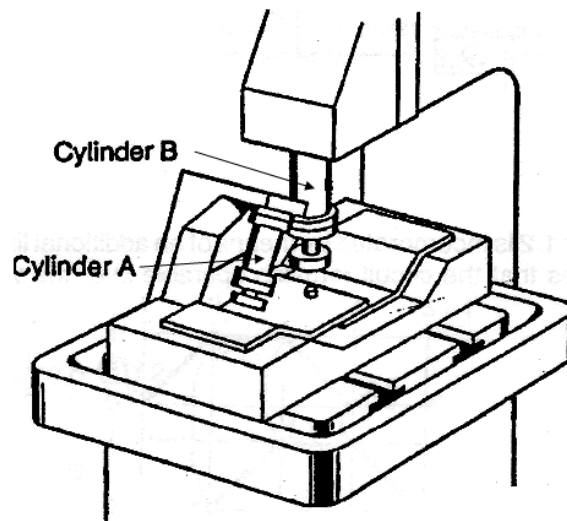

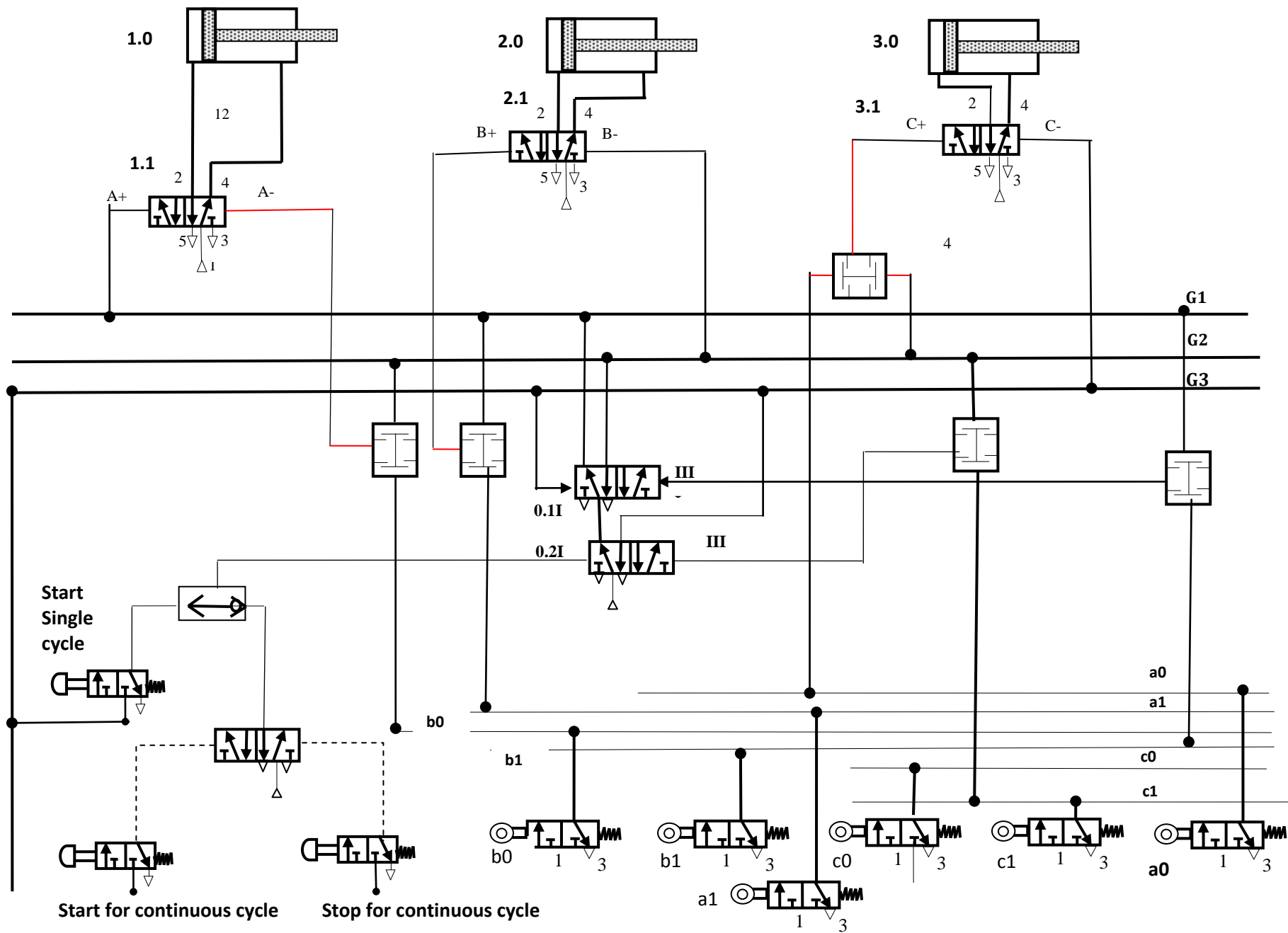

Q2 Solution

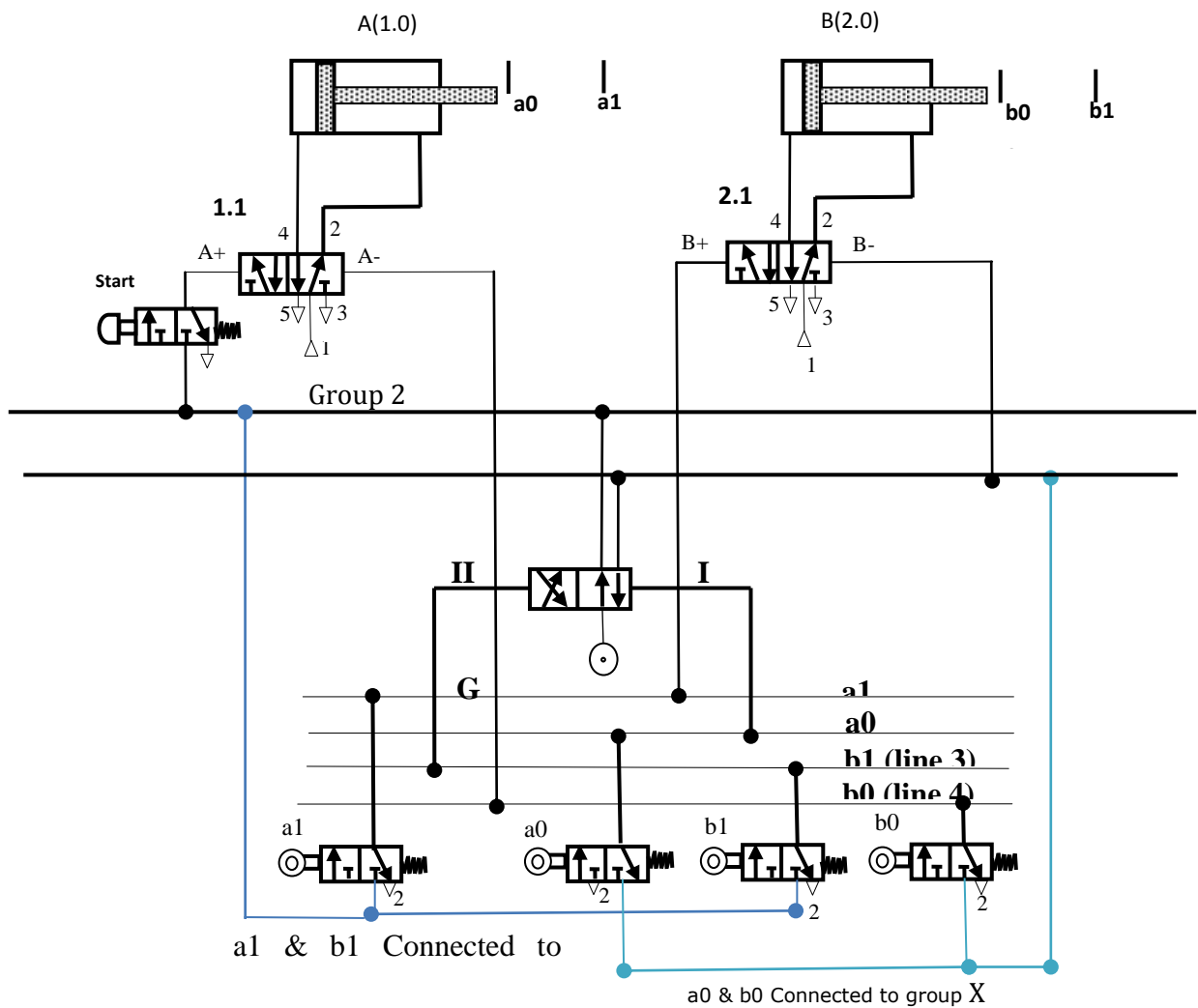
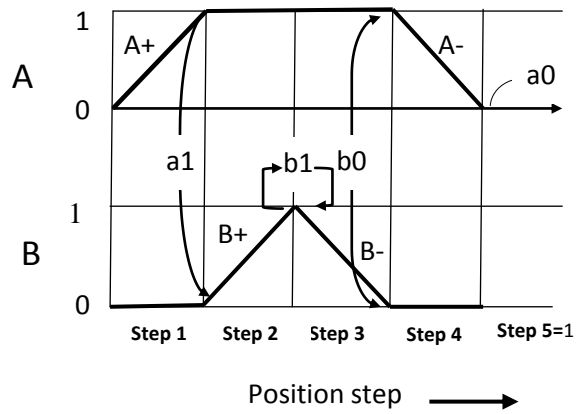

Pneumatic circuit for A+ B+ B- A-