

Module 4 General Purpose Machine Tools

Lesson

23

Construction,
Operation and Tool
layout in
Semiautomatic and
Automatic
lathes.

Instructional objectives

This lesson will enable the students ;

- (i) Illustrate the constructional features and uses of semiautomatic and automatic lathes.
- (ii) Show the kinematic system and explain the working principles of semiautomatic and automatic lathes of common use.
- (iii) Plan and visualise tool layout for machining in semiautomatic and automatic lathes.

(i) Constructional Features And Uses Of General Purpose Semiautomatic And Automatic Lathes.

Automation is incorporated in a machine tool or machining system as a whole for higher productivity with consistent quality aiming meeting the large requirements and overall economy. Such automation enables quick and accurate auxiliary motions, i.e., handling operations like tool – work mounting, bar feeding, tool indexing etc. repeatably with minimum human intervention but with the help of special or additional mechanism and control systems. These systems may be of mechanical, electro-mechanical, hydraulic or electronic type or their combination.

It is already mentioned that according to degree of automation machine tools are classified as,

- Non automatic where most of the handling operations irrespective of processing operations, are done manually, like centre lathes etc.
- Semiautomatic
- Automatic where all the handling or auxiliary operations as well as the processing operations are carried out automatically.

General purpose machine tools may have both fixed automation or flexible automation where the latter one is characterised by computer Numerical Control (CNC).

Amongst the machine tools, lathes are most versatile and widely used. Here automation of lathes only have been discussed.

The conventional general purpose automated lathes can be classified as,

- (a) Semiautomatic :
 - capstan lathe (ram type turret lathe)
 - turret lathe
 - multiple spindle turret lathe
 - copying (hydraulic) lathe
- (b) Automatic :
 - Automatic cutting off lathe
 - Single spindle automatic lathe
 - Swiss type automatic lathe
 - multiple spindle automatic lathes

The other categories of semiautomatic and automatic lathes are :

- o Vertical turret lathe
- o Special purpose lathes
- o Non conventional type, i.e., flexibly automatic CNC lathes, turning centre etc.

(a) Semiautomatic lathes

The characteristic features of such lathes are ;

- some major auxiliary motions and handling operations like bar feeding, speed change, tool change etc. are done quickly and consistently with lesser human involvement
- the operators need lesser skill and putting lesser effort and attention
- suitable for batch or small lot production
- costlier than centre lathes of same capacity.

Capstan and Turret lathes

The semiautomatic lathes, capstan lathe and turret lathe are very similar in construction, operation and application. Fig. 4.7.1 schematically shows the basic configuration of capstan lathe and Fig. 4.7.2 shows that of turret lathe.

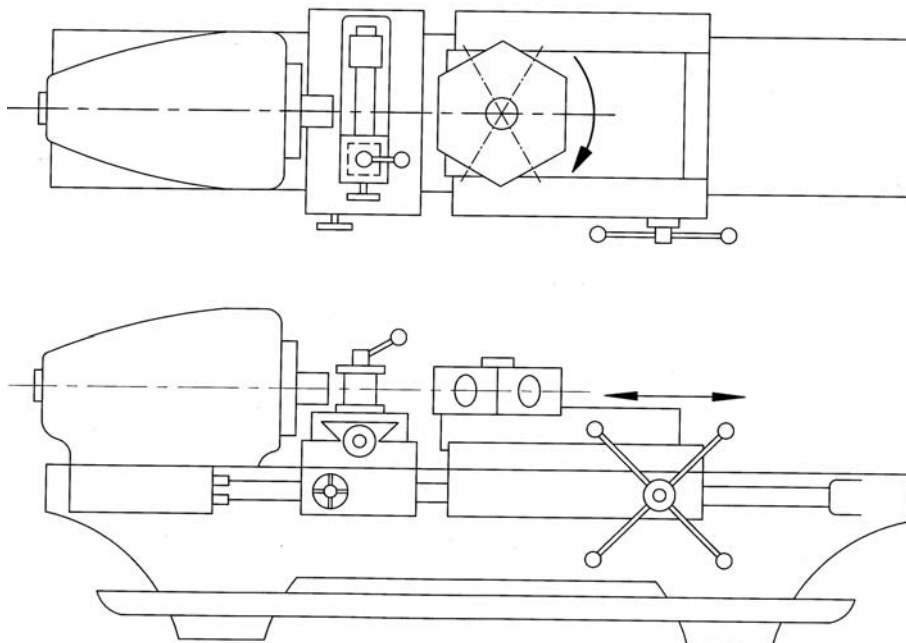

Fig. 4.7.1 Schematic configuration of capstan lathe.

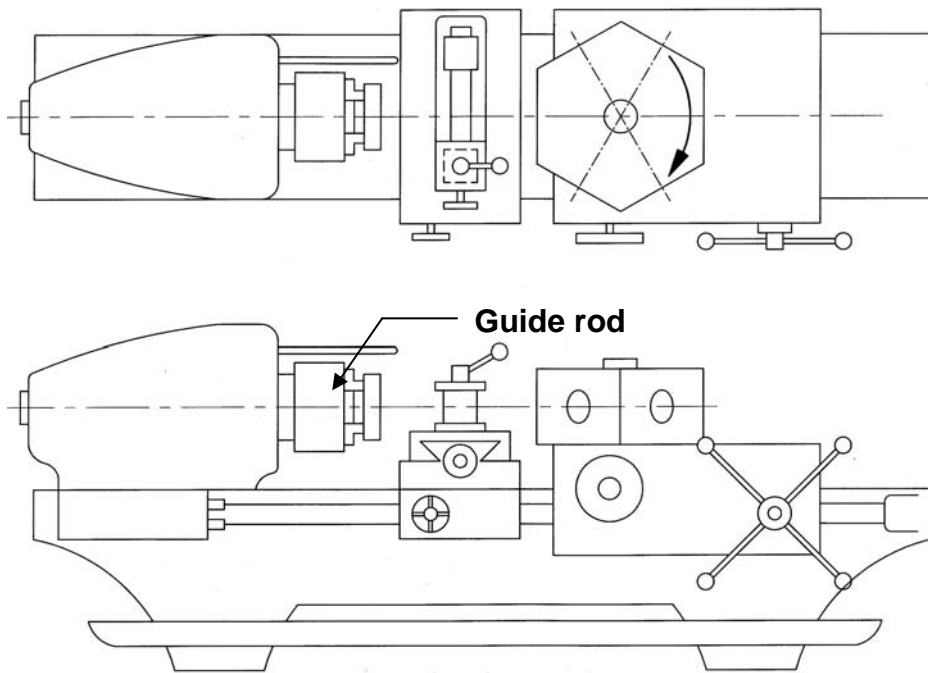

Fig. 4.7.2 Schematic configuration of turret lathe.

In contrast to centre lathes, capstan and turret lathes

- are semiautomatic
- possess an axially movable indexable turret (mostly hexagonal) in place of tailstock
- holds large number of cutting tools; upto four in indexable tool post on the front slide, one in the rear slide and upto six in the turret (if hexagonal) as indicated in the schematic diagrams.
- are more productive for quick engagement and overlapped functioning of the tools in addition to faster mounting and feeding of the job and rapid speed change.
- enable repetitive production of same job requiring less involvement, effort and attention of the operator for pre-setting of work–speed and feed rate and length of travel of the cutting tools
- are relatively costlier
- are suitable and economically viable for batch production or small lot production.

There are some differences in between capstan and turret lathes such as,

- Turret lathes are relatively more robust and heavy duty machines
- Capstan lathes generally deal with short or long rod type blanks held in collet, whereas turret lathes mostly work on chucking type jobs held in the quick acting chucks
- In capstan lathe, the turret travels with limited stroke length within a saddle type guide block, called auxiliary bed, which is clamped on the main bed as indicated in Fig. 4.7.1, whereas in turret lathe, the

heavy turret being mounted on the saddle which directly slides with larger stroke length on the main bed as indicated in Fig. 4.7.2

- One additional guide rod or pilot bar is provided on the headstock of the turret lathes as shown in Fig. 4.7.2, to ensure rigid axial travel of the turret head
- External screw threads are cut in capstan lathe, if required, using a self opening die being mounted in one face of the turret, whereas in turret lathes external threads are generally cut, if required, by a single point or multipoint chasing tool being mounted on the front slide and moved by a short leadscrew and a swing type half nut.

Fig. 4.7.3 and Fig. 4.7.4 are showing the pictorial views of a typical capstan lathe and a horizontal turret lathe respectively.

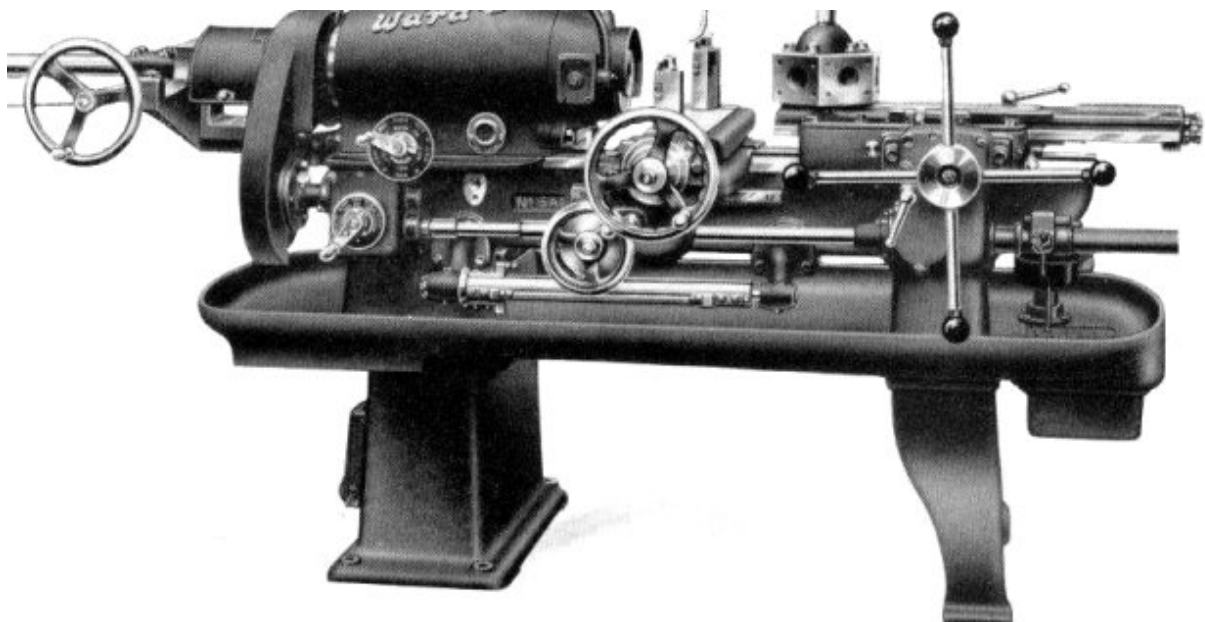

Fig. 4.7.3 Pictorial view of a capstan lathe

Ram type turret lathes, i.e., capstan lathes are usually single spindle and horizontal axis type. Turret lathes are also mostly single spindle and horizontal type but it may be also

- Vertical type and
- Multispindle type

Some more productive turret lathes are provided with preoptive drive which enables on-line presetting and engaging the next work-speed and thus help in reducing the cycle time.



Fig. 4.7.4 Pictorial view of a turret lathe.

Multiple spindle Vertical Turret lathe

Turret lathes are mostly horizontal axis single spindle type. The multiple spindle vertical turret lathes are characterised by :

- Suitably used for large lot or mass production of jobs of generally ;
 - Δ chucking type
 - Δ relatively large size
 - Δ requiring limited number of machining operations
- Machine axis – vertical for
 - Δ lesser floor space occupied
 - Δ easy loading and unloading of blanks and finished jobs
 - Δ relieving the spindles of bending loads due to job – weight.
- Number of spindle – four to eight.

Fig. 4.7.5 visualise the basic configuration of multiple spindle vertical turret lathes which are comprised mainly of a large disc type spindle carrier and a tool holding vertical ram as shown.

Such vertical turret lathes are of three categories :

* **Parallel processing type :**

The spindle carrier remains stationary. Only the tool slides move with cutting tools radially and axially. Identical jobs (say six) are simultaneously mounted and machined in the chucks parallelly at all stations each one having same set of axially and / or radially moving cutting tools.

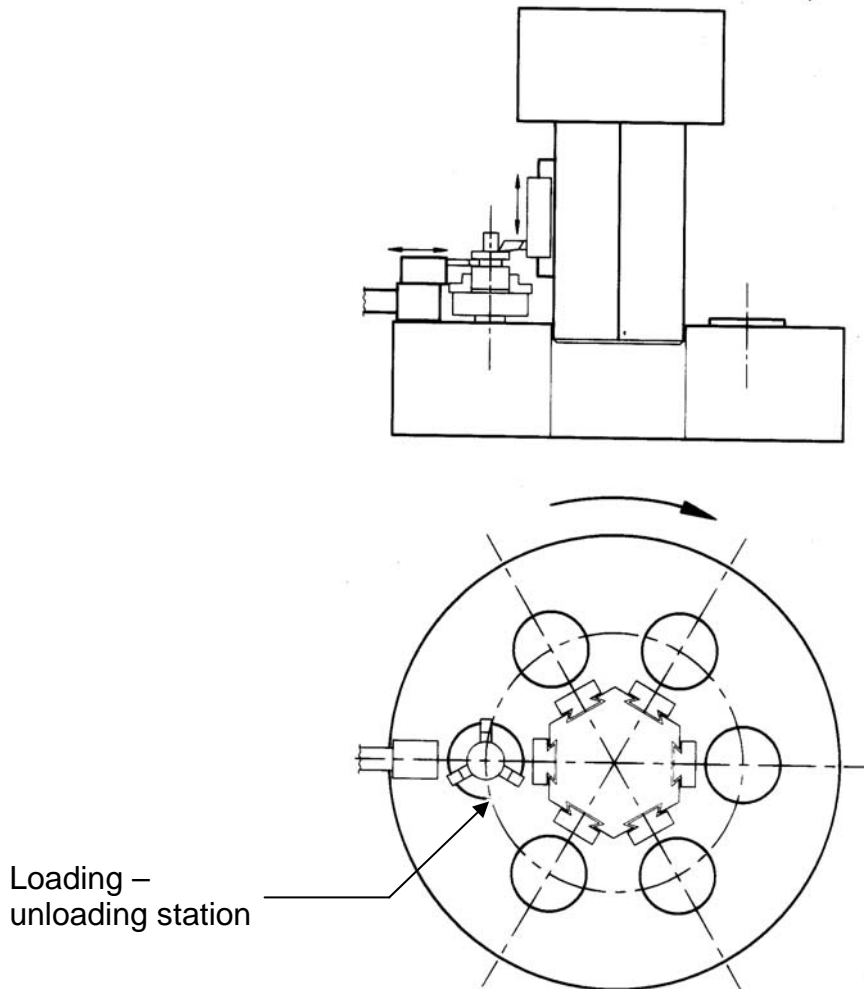

Fig. 4.7.5 Basic configuration of multispindle automatic vertical lathe

* **Progressively processing type :**

The spindle carrier with the blanks fitted in the chucks on the rotating spindle is indexed at regular interval by a Geneva mechanism. At each station the job undergoes a few preset machining work by the axially and / or radially fed cutting tools. The blank getting all the different machining operations progressively at the different work stations is unloaded at a particular station where the finished job is replaced by another fresh blank. This type of lathes are suitable for jobs requiring large number of operations.

* **Continuously working type :**

Like in parallel processing type, here also each job is finished in the respective station where it was loaded. The set of cutting tools, mostly fed only axially along a face of the ram continuously work on the same blank throughout its one cycle of rotation along with the spindle carrier. The tool ram having same tool sets on its faces also rotate simultaneously along with the spindle carrier which after each rotation halts for a while for unloading the finished job and loading a fresh blank at a particular location. Such system is also suitable for jobs requiring very few and simple machining operations.

• **Hydraulic copying (tracer controlled) lathes**

Jobs having steps, tapers and / or curved profiles, as typically shown in Fig. 4.7.6, are conveniently and economically produced in batch or lot in semiautomatically operated tracer controlled hydraulic copying lathe. The movement of the stylus along the template provided with the same desired job-profile) is hydraulically transmitted to the cutting tool tip which replicates the template profile.

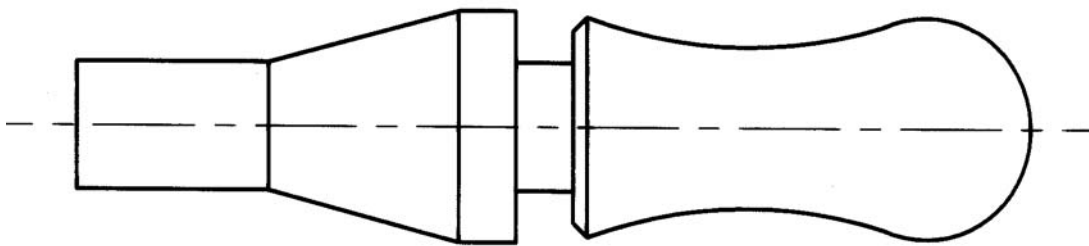

Fig. 4.7.6 A typical job suitable for copy turning.

(b) General Purpose Automatic lathes

Automatic lathes are essentially used for large lot or mass production of small rod type of jobs. Automatic lathes are also classified into some distinguished categories based on constructional features, operational characteristics, number of spindles and applications as follows

- Single spindle
 - △ Automatic cutting off lathes
 - △ Automatic (screw cutting) lathe
 - △ Swiss type automatic lathe
- Multispindle automatic lathe

Automatic cutting off lathe

These simple but automatic lathes are used for producing short work pieces of simple form by using few cross feeding tools. In addition to parting some simple operations like short turning, facing, chamfering etc. are also done.

Single spindle automatic lathe

The general purpose single spindle automatic lathes are widely used for quantity or mass production (by machining) of high quality fasteners; bolts, screws, studs etc., bushings, pins, shafts, rollers, handles and similar small metallic parts from long bars or tubes of regular section and also often from separate small blanks.

Fig. 4.7.7 shows a typical single spindle automatic lathe.

Unlike the semiautomatic lathes, single spindle automats are :

- preferably and essentially used for larger volume of production i.e., large lot production and mass production
- used always for producing jobs of rod, tubular or ring type and of relatively smaller size.
- run fully automatically, including bar feeding and tool indexing, and continuously over a long duration repeating the same machining cycle for each product
- provided with upto five radial tool slides which are moved by cams mounted on a cam shaft
- of relatively smaller size and power but have higher spindle speeds

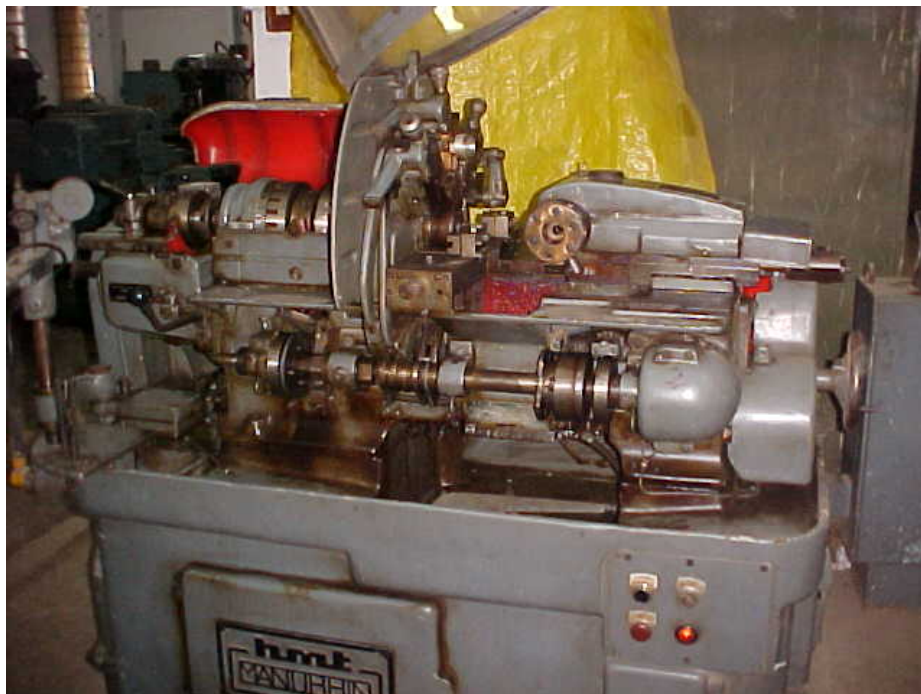

Fig. 4.7.7 A typical single spindle automatic lathe.

Swiss type automatic lathe

The characteristics and applications of these single spindle automatic lathes are :

- In respect of application :
 - Used for lot or mass production of thin slender rod or tubular jobs, like components of small clocks and wrist watches, by precision machining;
 - Job size (approximately)
 - Diameter range – 2 to 12 mm
 - Length range – 3 to 30 mm
- Dimensional accuracy and surface finish – almost as good as provided by grinding
- In respect of configuration and operation
 - The headstock travels enabling axial feed of the bar stock against the cutting tools as indicated in Fig. 4.7.8
 - There is no tailstock or turret
 - High spindle speed (2000 – 10,000 rpm) for small job diameter
 - The cutting tools (upto five in number including two on the rocker arm) are fed radially
 - Drilling and threading tools, if required, are moved axially using swivelling device(s)
 - The cylindrical blanks are prefinished by grinding and are moved through a carbide guide bush as shown.

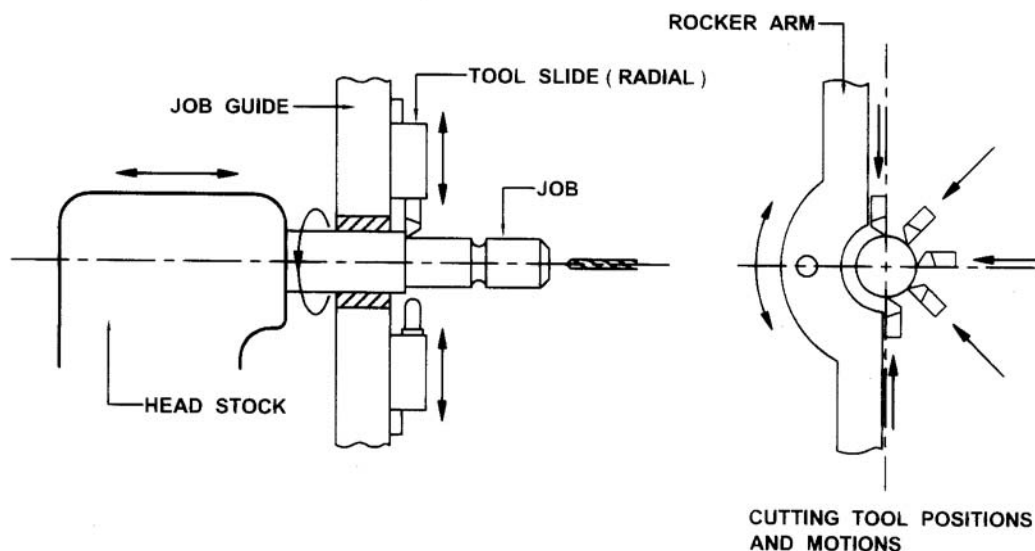

Fig. 4.7.8 Basic principle of Swiss type automatic lathe.

Multispindle automatic lathes

For further increase in rate of production of jobs usually of smaller size and simpler geometry. Multispindle automatic lathes having four to eight parallel spindles are preferably used. Unlike multispindle turret lathes, multispindle automatic lathes ;

- are horizontal (for working on long bar stocks)
- work mostly on long bar type or tubular blanks

Multiple spindle automats also may be parallel action or progressively working type. Machining of the inner and outer races in mass production of ball bearings are, for instance, machined in multispindle automatic lathes.

(ii) Kinematic Systems And Working Principles Of Semi Automatic And Automatic Lathes

The kinematic systems and basic principles of working of the following general purpose semi-automatic and automatic lathes of common use have been visualised and briefly discussed here :

(a) Semi-automatic lathes :

- Capstan and single spindle turret lathe
- Hydraulic copying lathe

(b) Automatic lathes

- Single spindle automatic (screw cutting) lathe
- Swiss type automatic lathe

Kinematic system and working principle of capstan lathe

Like general configurations and applications, the basic kinematic systems are also very similar in capstan lathes and turret lathes (particularly single spindle bar and horizontal types) in respect of their major functions, i.e.,

- bar feeding mechanism
- turret moving and indexing
- speed and feed drives

Bar feeding mechanism of capstan lathe

Fig. 4.7.9 typically shows the kinematic arrangement of feeding and clamping of bar stock in capstan lathes.

The bar stock is held and tightly clamped in the push type spring collet which is pushed by a push tube with the help of a pair of bell-crank levers actuated by a taper ring as shown in Fig. 4.7.9. Bar feeding is accomplished by four elementary operations;

- unclamping of the job – by opening the collet
- bar feed by pushing it forward
- clamping of the bar by closing the collet
- free return of the bar-pushing element

After a job is complete and part off, the collet is opened by moving the lever manually rightward to withdraw the push force on the collet. Further moving of the lever in the same direction causes forward push of the bar with the help of the ratchet – paul system shown. After the projection of the bar from the collet face to the desired length controlled by a pre-set stop – stock generally held in one face of the turret or in a separate swing stop, the lever is moved leftward resulting closing of the collet by clamping of the barstock. Just before clamping of the collet, the leftward movement of the lever pushes the bar feeder (ratchet) back freely against the paul.

Turret indexing mechanism in capstan and turret lathes

Turret indexing mechanism of capstan and single spindle turret lathe is typically shown schematically in Fig. 4.7.10.

The turret (generally hexagonal) holding the axially moving cutting tools have the following motions to be controlled mechanically and manually ;

- forward axial traverse comprising;
 - △ quick approach – manually done by rotating the pinion as shown
 - △ slow working feed – automatically by engaging the clutch
 - △ stop at preset position depending upon the desired length of travel of the individual tools
- quick return – manually done by disengaging the clutch and moving the turret back
- indexing of the turret by 60° (or multiple of it) – done manually by further moving the turret slide back.

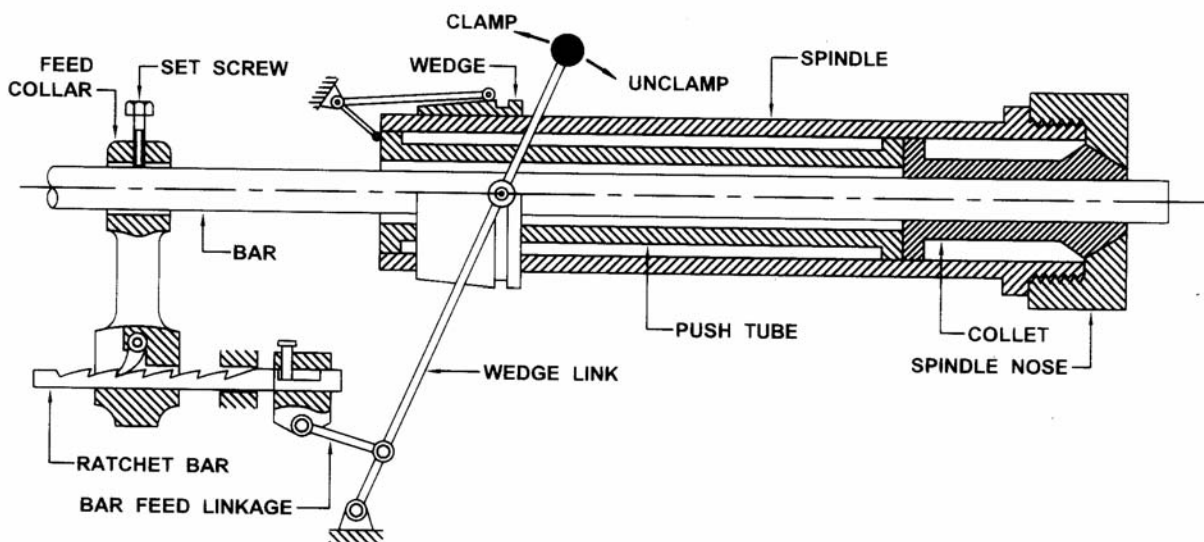

Fig. 4.7.9 Typical bar feeding mechanism in capstan lathe.

Just before indexing at the end of the return stroke, the locking pin is withdrawn by the lever which is lifted at its other end by gradually riding against the hinged wedge as indicated in Fig. 4.7.10 (a). Further backward travel of the turret slide causes rotation of the free head by the indexing pin

and lever as indicated in Fig. 4.7.10 (b). Rotation of the turret head by exact angle is accomplished by insertion of the locking pin in the next hole of the six equispaced holes. After indexing and locking, the turret head is moved forward with the next cutting tool at its front face when the roller of the lever returns through the wider slot of the wedge without disturbing the locking pin as indicated in the figure. The forward motion of the turret head is automatically stopped when the set-screw corresponding to the working tool is arrested by the mechanical stop. The end position and hence length of travel of the tool is governed by presetting the screw. There are six such screws, each one corresponds with particular face or tool of the turret. The drum holding those equispaced six screw with different projection length is rotated along with the indexing (rotation) of the turret head by a pair of bevel gears (1:1) as indicated in Fig. 4.7.10 (a). The bottom most screw, which corresponds with the tool on the front face of the turret, when hits or touches the stop, the turret movement is stopped either manually by feeling or automatically by disengaging the clutch between the feed rod and the turret slide.

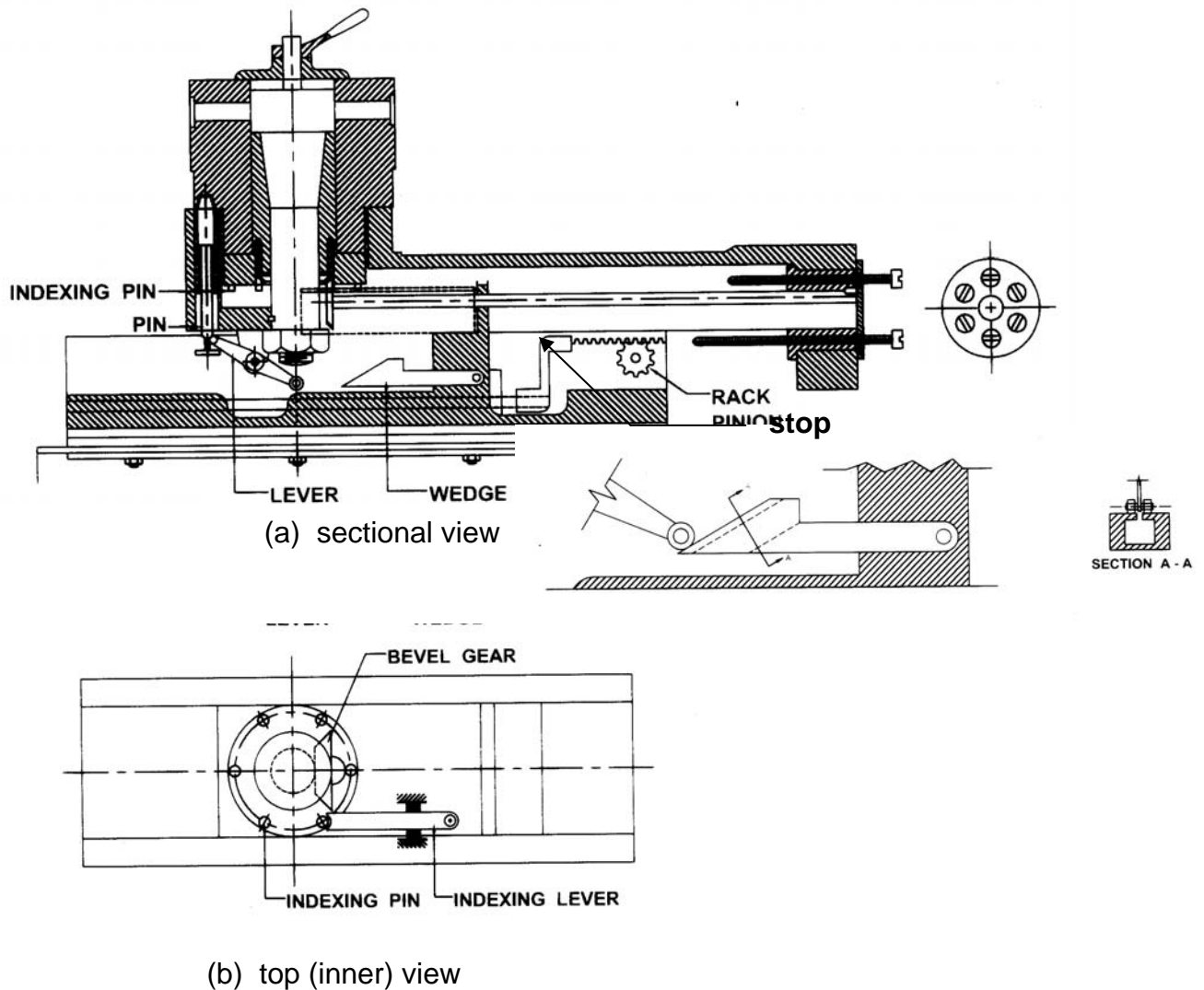

Fig.4.7.10 Turret indexing in capstan and turret lathe.

Kinematics and working principle of hydraulic copying lathe

Hydraulic drive is often preferably used in some machine tools for smooth motions without jerk and noise, self lubrication, flexible transmission system and stepless variation in speed and feed despite the limitations like larger space requirement, oil leakage, difficult maintenance etc.

Fig. 4.7.11 typically shows the circuitry of a hydraulically driven (tool travel) drilling machine. The direction and length of travel of the drilling head fitted on the moving piston are controlled by movement of the spool of the direction control valve which is actuated by the pilot valve and governed by the electromechanical stop as indicated in the figure. The rate of travel of the drill head i.e., the feed rate is governed by the throttle or metre controlling valve which is again controlled by a template like cam and a follower coupled with the spool of the throttle valve as shown in Fig. 4.7.11. To keep feed rate constant irrespective of the working force on the piston, a pressure reducing valve is provided prior to the throttle valve. The pressure reducing valve helps keep its exit pressure i.e., input pressure of the throttle valve fixed to a preset value irrespective of the input pressure of the pressure reducing valve which varies with the working load on the drill piston. Constant pressure difference keeps constant fluid flow rate through the throttle valve resulting constant feed rate irrespective of the cutting force.

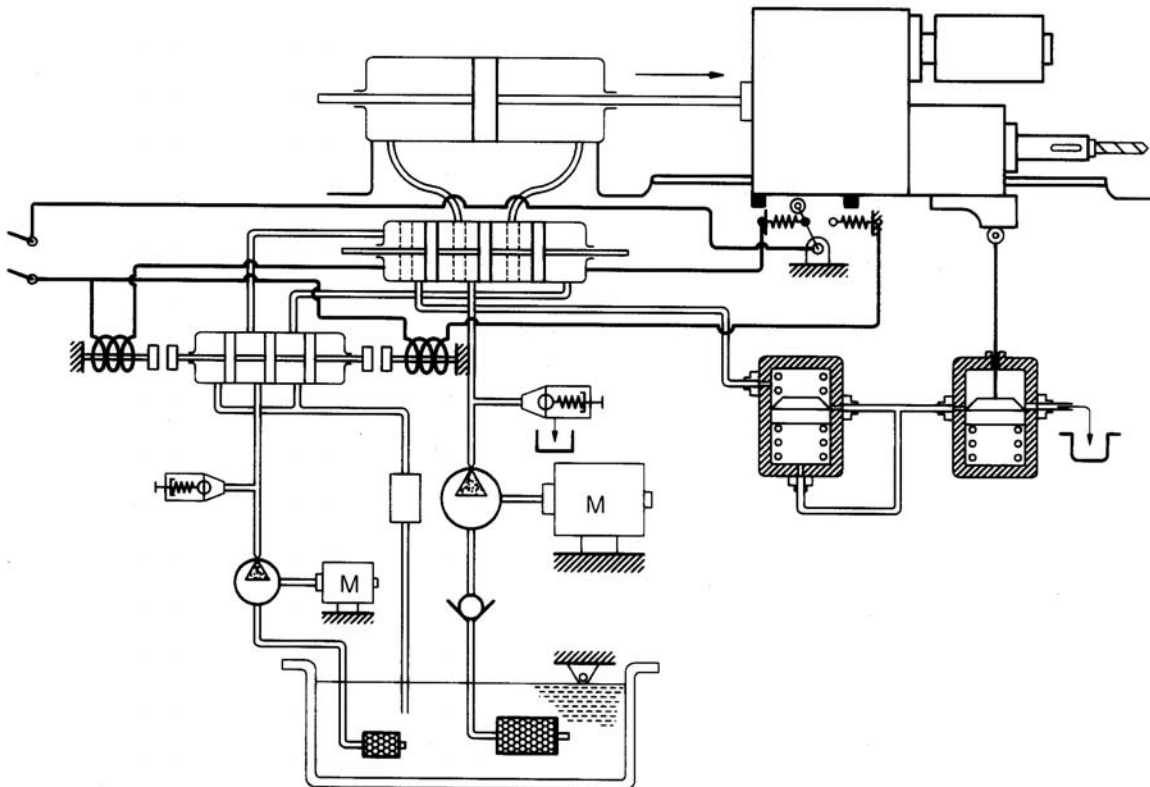

Fig. 4.7.11 Circuitry and kinematic system of hydraulically driven machine tool

Fig.4.7.12 schematically shows the principle of typical hydraulic copying lathe. The cross feed is controlled, under fixed longitudinal feed, hydraulically. When the stylus moves in the transverse direction slightly (by say Δx) due to slope or profile in the fixed template, the ports open enabling the high pressure fluid enter in the lower chamber. Since the piston is fixed, the sliding cylinder holding the cutting tool will start moving down. When the tool also retracts by Δx the ports get closed. This way the incremental or discrete motion of the stylus is replicated by the tool tip resulting true copying of the profile from the template to the job.

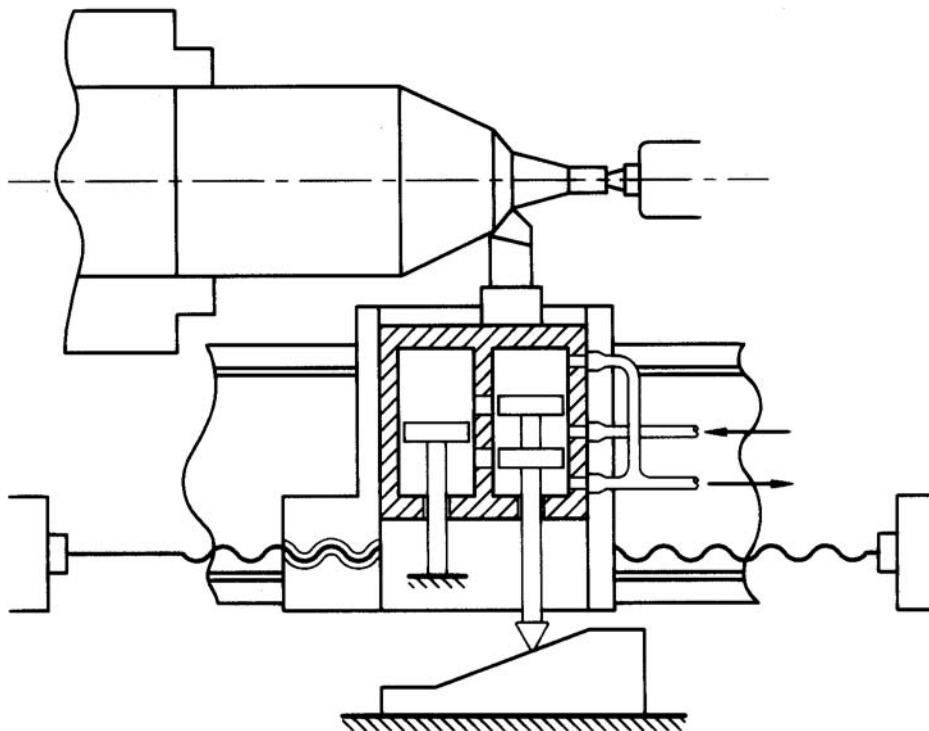

Fig.4.7.12 Principle of hydraulic copy turning.

- **Kinematic system and working principle of automatic lathes of common use.**

- **Single spindle automatic lathe**

This general purpose and widely used automatic lathe is also known as single spindle automatic screw cutting lathe (ssASCL) because such lathes were introduced aiming mainly mass production of fasteners having screw threads.

Fig. 4.7.13 schematically shows the typical kinematic system of single spindle automat. The major characteristic functions that are automatically accomplished in sequence and proper synchrony in such lathes are :

- △ spindle speed change – magnitude and direction of rotation
- △ bar feeding
- △ transverse tools – feeding
- △ turret indexing and travelling

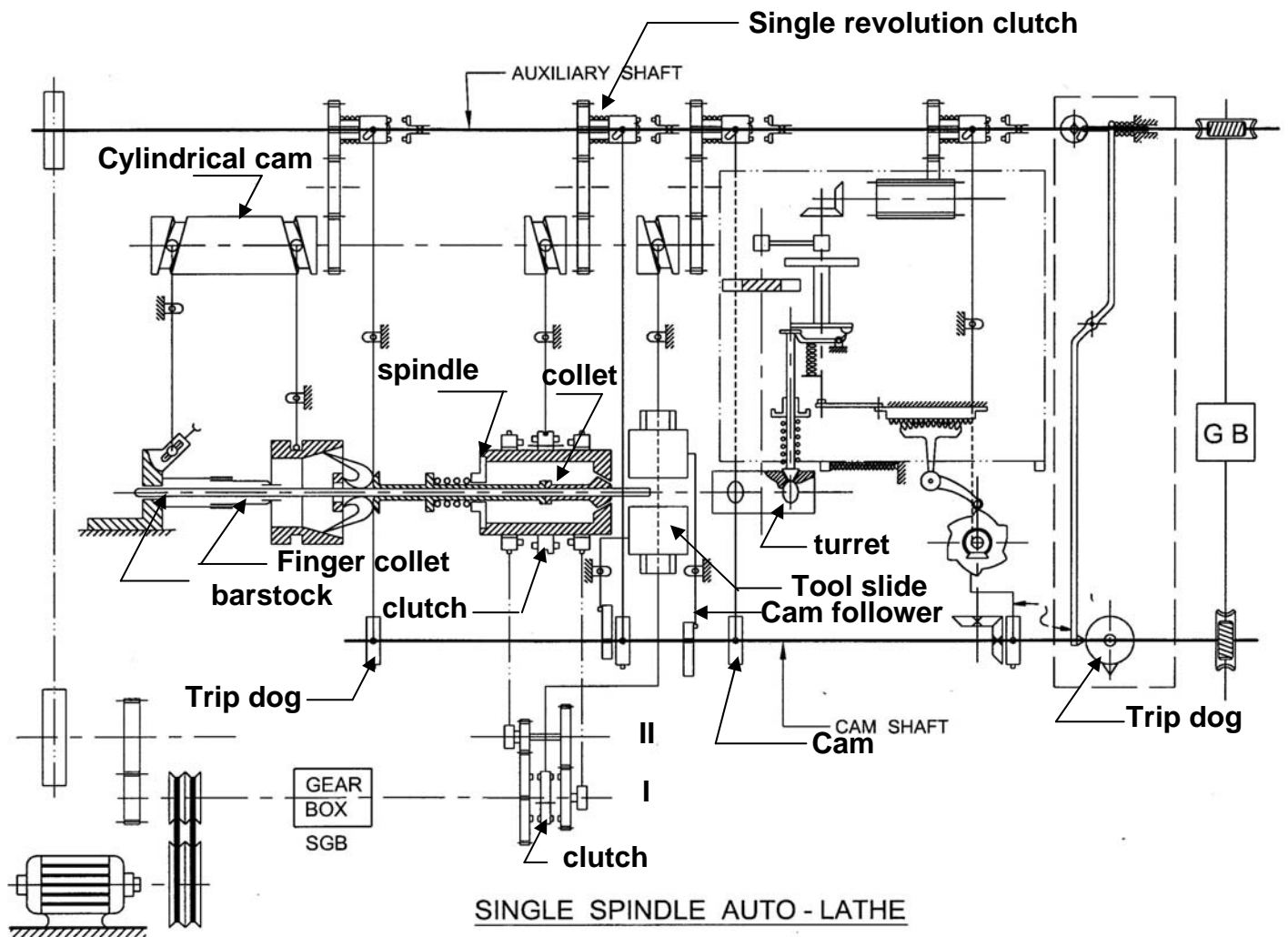

Fig. 4.7.13 Typical kinematic system of single spindle automatic lathe.

Δ Change of spindle speed

Repetitive production in large volume and limited ranges of job – tool materials and job – diameter necessitate a small number of spindle speeds in automatic lathes unlike centre lathes. However, at least two speeds, high and low (for threading etc.) and provision of reversal of those speeds need to be provided in automatic lathes. Power and speed are transmitted from the motor to shaft – I through belt-pulley and a speed gear box (SGB) if required as can be seen in Fig. 4.7.13. The two gear loosely mounted on shaft I are in mesh with two gears fixed on shaft II. Rotations are transmitted from shaft II to the spindle by two pairs of chain and sprockets as indicated in the kinematic diagram (Fig. 4.7.13). The two sprockets are loosely mounted on the spindle and simultaneously rotate at the same speed, low or high, but in opposite directions. The spindle is made to rotate at high or low speed and clockwise or anticlockwise by engaging the clutches on shaft I and the spindle respectively. The clutch is shifted by a lever and cylindrical cam which is rotated at the desired moment by one revolution only with the help of a single

revolution clutch which is again triggered by a trip dog controlled by the camshaft as shown in the figure.

△ **Bar feeding mechanism**

For feeding the barstock to a desired projection length after completing machining and parting a job, first the collet is opened by withdrawing the push force by moving the taper ring outward by a lever automatically with the help of the cylindrical cam. Then the cam at the other end of the cylinder pushes the rod forward using the lever, a slide and finger collet. Next half of the rotation of that cylindrical cam accomplishes clamping collet and return of the finger collet by moving the levers in opposite direction.

Here again, the cylindrical cam is rotated by only one revolution by actuating another single revolution clutch at the proper moment by a trip dog as indicated in the figure.

△ **Transverse tool feeds**

The radially moving cutting tools (upto five) are fed sequentially at preset timings and desired length and rate of travel by individual cams mounted on the cam shaft which rotates slowly with one rotation for one machining cycle i.e., one product.

All the single revolution clutches are mounted on the auxiliary shaft which positively rotates at a constant speed of 120 rpm. Rotation is transmitted from that to the cam shaft through speed reduction and a feed gear box (FGB) to vary the cam-shaft speed depending upon the cycle time for each job.

△ **Feed motions of the axially fed cutting tools mounted on the turret**

The end points, length and rate of travel of the six tools on the turret are governed by a single plate cam having six lobes corresponding to the tools in the turret as shown in the figure. The rotational speed of that cam is kept same as that of the cam shaft.

△ **Turret indexing mechanism**

The hexagonal turret is rotated (for indexing) by a Geneva mechanism where a Geneva disc having six radial slots is driven by a revolving pin. Before starting rotation, the locking pin is withdrawn by a cam lever mechanism shown in the diagram. The single rotation of the disc holding the indexing pin is derived from the auxiliary shaft with the help of another single revolution clutch as indicated

• **Kinematic system and operating principle of Swiss type automatic lathe**

The kinematic diagram of typical Swiss type automatic lathe is schematically shown in Fig. 4.7.14.

Both the high speed of the spindle and the low speed of the cam shaft are derived from the motor as indicated in the diagram. All the cutting tools mounted on the transverse slides are travelled to desired depth and at desired feed rate by a set of plate cams mounted on the cam shaft. The headstock with the spindle having the barstock clamped in it is moved forward and

returned at desired feed rate by a set of plate cams mounted on the camshaft as shown.

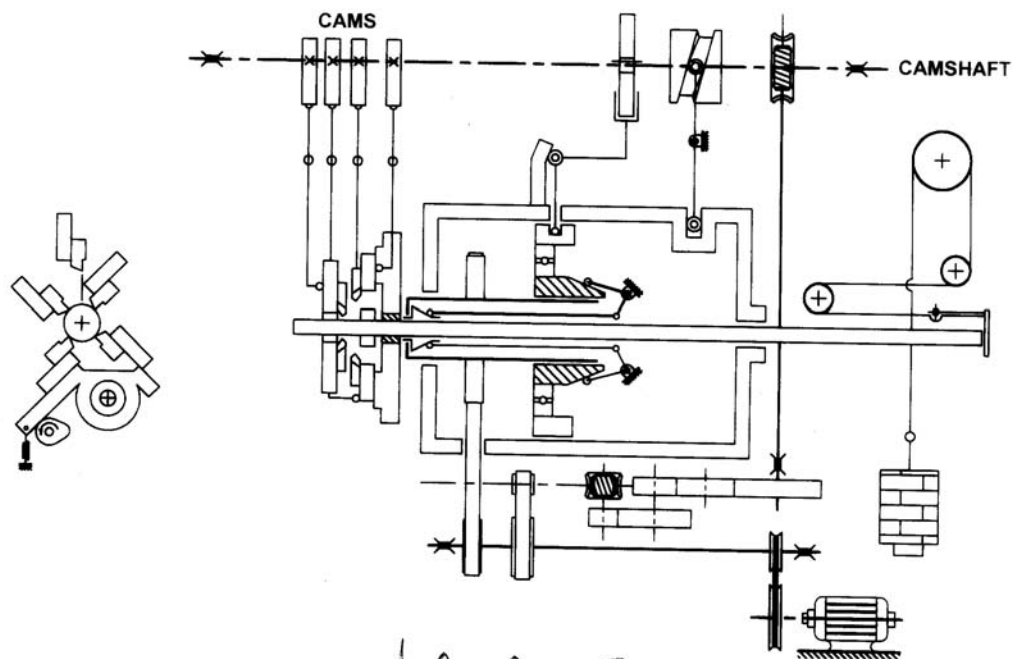

Fig. 4.7.14 Kinematic system of Swiss type automatic lathe.

Feeding of the bar, after completion and parting of a job is done sequentially by

- Opening the collet by shifting the taper ring by a cam as shown
- Pushing the bar, against the last working tool, by a gravitational force
- Collet clamping by return of the ring

(iii) Process Planning And Tool Layout For Machining A Product In Semi-Automatic And Automatic Lathes.

The procedural steps to be followed in sequence for batch or lot production of a job by machining in semi-automatic and automatic general purpose machine tools are :

- (a) Thorough study of the job to be produced: in respect of :
 - volume of production, i.e., number of pieces of the specific job to be produced
 - material and its properties
 - size and shape
 - surfaces to be machined
 - required dimensions with tolerances and surface finish
 - end use of the product

- (b) Selection of machine tool (after studying the job): in respect of ;
 - type
 - size
 - precision
 - kind and degree of automation
- (c) Selection of blank (based on job and machine selected): in respect of;
 - bar chucking or housing type
 - preformed by; casting, forging, rolling etc.
 - if bar type; cross section (circular, tubular, square, hexagon etc.)
 - nominal size based on largest dimensions and availability
 - preformed by hot working or cold working
- (d) Identification and listing of the elementary machining operations required, depending upon the product configuration
- (e) Combine elementary machining operations as much as possible for saving time
- (f) Sequence the operations (after combining)
- (g) Select cutting tools: in respect of;
 - type
 - material
 - size
 - geometry
 - availability
 depending upon the machining operations (after combining) and work material
- (h) work scheduling or preparation of the instruction sheet or operation chart giving column-wise :
 - description of the machining work to be done in sequence
 - cutting tools : type and location
 - speed and feed for each operation
 - length of travel of the tools
 - cutting fluid application;
 - yes or not required
 - type of cutting fluid
- (i) Tool layout : schematically showing the type and configuration of the cutting tools and their location and mounting.

A typical tool layout for a particular job being machined in a single spindle automatic lathe is schematically shown in Fig. 4.7.15.

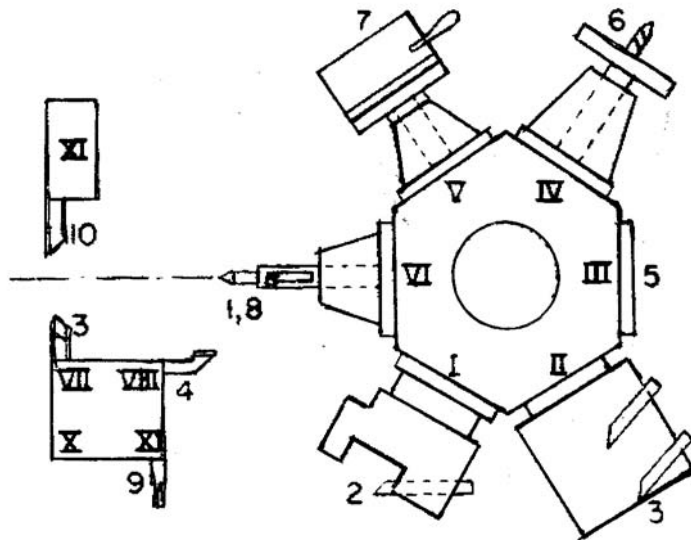
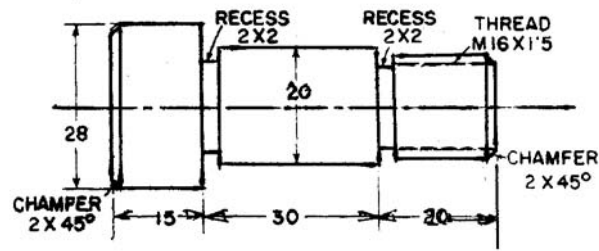

Fig. 4.7.15 Tool layout for a typical job in single automatic lathe.

(iv) Case Study : As An Example

- **Task (say)** : 2500 pieces of hollow hexagonal headed mild steel bolts, as shown in Fig. 4.7.16, are to be produced by machining.
- o **Machine tool selected** :
Single spindle automatic lathe for
 - Lot production (for smaller volume of production capstan lathe is better)
 - Circular bar type job
 - Common machinable material
 - Simple machining operations required

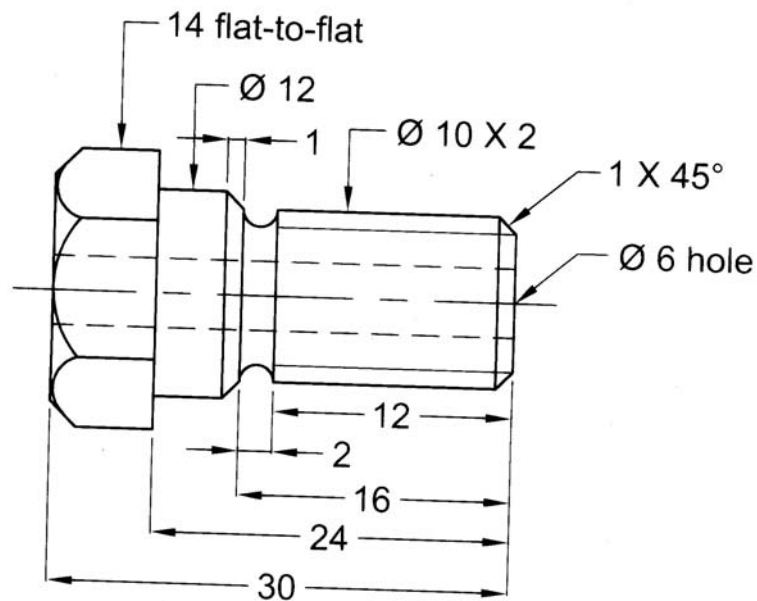

Fig. 4.7.16 Shape and dimension of the specific job

- o **Blank selected :**
Hot rolled hexagonal section mild steel bars for;
 - saving machining of the hexagonal head portion
 - the hexagonal head is of standard size which is available
 - job size – reasonable for single spindle automatic
 - not being precision job

- o **Elementary machining operations** – identified and listed :
 - Facing
 - Centering
 - Chamfering (1) – front
 - Chamfering (2) – middle portion
 - Chamfering (3) – bolt head
 - Rough turning (1) – to make circular from hexagon
 - Rough turning (2) – to reduce diameter to 12 mm
 - Finish turning – to $\phi 10$
 - Drilling
 - Grooving (forming)
 - Thread cutting
 - Initial parting
 - Parting

o **Combining elementary operations**

- Δ combining operations to be done by a compound tool in a single travel from one tool position
- Δ paralleling or overlapping operations to be done by different tools moving in different directions.

The listed elementary operations can be combined and sequenced as follows :

- 1 Rough turning (1), initial parting and rear chamfering (3)
- 2 Rough turning (to $\phi 12$) and drilling and centering (for the next job)
- 3 Finish turning ($\phi 10$)
- 4 Spot facing and front chamfering (1)
- 5 Grooving and central chamfering (2)
- 6 Thread cutting
- 7 Parting

• **Scheduling – operation chart indicating tools and tool positions and machining conditions.**

N = spindle speed (rpm), s = feed (mm/rev), L = tool travel, CF = cutting fluid
 HT (1) = hexagonal turret face 1, RS = Rear slide, FS = front slide, VS = vertical slide

Table – 1 : Scheduling; operation chart

Sl. No.	Operation	Tool	Tool position	N	S	L	CF
1	Stop stock & bar feed	Stop	HT (1)	-	-	-	N
2	Rough turning (1) Initial parting Chamfering (3)	Turning tool Formed Parting tool	HT(2) RS	640	0.10 0.05	30 6	Y Y
3	Rough parting (2) Drilling ($\phi 6$) centering	Turning tool Drill	HT(3)	640	0.10	50	Y
4	Finish turning	Turning tool	HT(4)	640	0.05	25	Y
5	Spot facing Chamfering (1)	Compound tool	HT(5)	640	0.05	5	Y
6	Grooving Chamfering (2)	Form tool	FS	640	0.05	10	Y
7	Threading	Solid die	HT(6)	56	2	20	Y
8	Parting	Parting tool	VS	640	0.05	12	Y

- **Tool layout –**

The possible tool layout made based on the scheduling made for the product is schematically shown in Fig. 4.7.17.

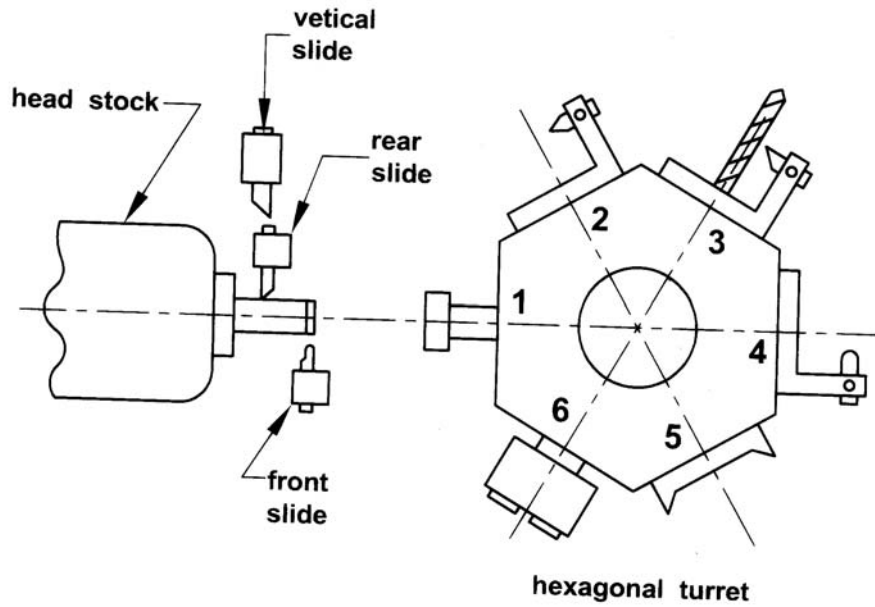

Fig. 4.7.17 Tool layout for machining the given job in single spindle automatic lathe