

Module 3: Architecture of Hybrid and Electric Vehicles

Lecture 5: Basic Architecture of Hybrid Drive Trains and Analysis of Series Drive Train

Basic Architecture of Hybrid Drive Trains and Analysis of Series Drive Train

Introduction

The topics covered in this chapter are as follows:

- Hybrid Electric Vehicles (HEV)
- Energy use in conventional vehicles
- Energy saving potential of hybrid drive trains
- Various HEV configurations and their operation modes

The Hybrid Electric Vehicle (HEV)

What exactly is an HEV? The definition available is so general that it anticipates future technologies of energy sources. The term *hybrid vehicle* refers to a vehicle with at least two sources of power. A *hybrid-electric vehicle* indicates that *one source of power* is provided by an *electric motor*. The *other source of motive power* can come from a number of different technologies, but is typically provided by an *internal combustion engine* designed to run on either gasoline or diesel fuel. As proposed by Technical Committee (Electric Road Vehicles) of the International Electrotechnical Commission, *an HEV is a vehicle in which propulsion energy is available from two or more types of energy sources and at least one of them can deliver electrical energy*. Based on this general definition, there are many types of HEVs, such as:

- the gasoline ICE and battery
- diesel ICE and battery
- battery and FC
- battery and capacitor
- battery and flywheel
- battery and battery hybrids.

Most commonly, the propulsion force in HEV is provided by a combination of electric motor and an ICE. The electric motor is used to improve the energy efficiency (improves fuel consumption) and vehicular emissions while the ICE provides extended range capability.

Energy Use in Conventional Vehicles

In order to understand how a HEV may save energy, it is necessary first to examine how conventional vehicles use energy. The breakdown of energy use in a vehicle is as follows:

- In order to maintain movement, vehicles must produce power at the wheels to overcome:
 - a. aerodynamic drag (air friction on the body surfaces of the vehicle, coupled with pressure forces caused by the air flow)
 - b. rolling resistance (the resistive forces between tires and the road surface)
 - b. resistive gravity forces associated with climbing a grade
- Further, to accelerate, the vehicle must its inertia. Most of the energy expended in acceleration is then lost as heat in the brakes when the vehicle is brought to a stop.
- The vehicle must provide power for accessories such as heating fan, lights, power steering, and air conditioning.
- Finally, a vehicle will need to be capable of delivering power for acceleration with very little delay when the driver depresses the accelerator, which may necessitate keeping the power source in a standby (energy-using) mode.

A conventional engine-driven vehicle uses its engine to translate fuel energy into shaft power, directing most of this power through the drivetrain to turn the wheels. Much of the heat generated by combustion cannot be used for work and is wasted, both because heat engines have theoretical efficiency limit. Moreover, it is impossible to reach the theoretical efficiency limit because:

- some heat is lost through cylinder walls before it can do work
- some fuel is burned at less than the highest possible pressure
- fuel is also burned while the engine is experiencing negative load (during braking) or when the vehicle is coasting or at a stop, with the engine idling.

Although part of engine losses would occur under any circumstances, part occurs because in conventional drivetrains, engines are sized to provide very high levels of

peak power for the acceleration capability expected by consumers, about 10 times the power required to cruise at 100Km/h. However, the engines are operated at most times at a small fraction of peak power and at these operating points they are quite inefficient.

Having such a large engine also increases the amount of fuel needed to keep the engine operating when the vehicle is stopped or during braking or coasting, and increases losses due to the added weight of the engine, which increases rolling resistance and inertial losses. Even gradeability requirements (example: 55 mph up a 6.5% grade) require only about 60 or 70% of the power needed to accelerate from 0 to 100Km/h in under 12 seconds.

The **Figure 1** shows the translation of fuel energy into work at the wheels for a typical midsize vehicle in urban and highway driving. From **Figure 1** it can be observed that:

- At best, only 20% of the fuel energy reaches the wheels and is available to overcome the tractive forces, and this is on the highway when idling losses are at a minimum, braking loss is infrequent, and shifting is far less frequent.
- Braking and idling losses are extremely high in urban driving and even higher in more congested driving, e.g., within urban cores during rush hour. Braking loss represents 46% of all tractive losses in urban driving. Idling losses represent about one sixth of the fuel energy on this cycle.
- Losses to aerodynamic drag, a fifth or less of tractive losses in urban driving, are more than half of the tractive losses during highway driving.

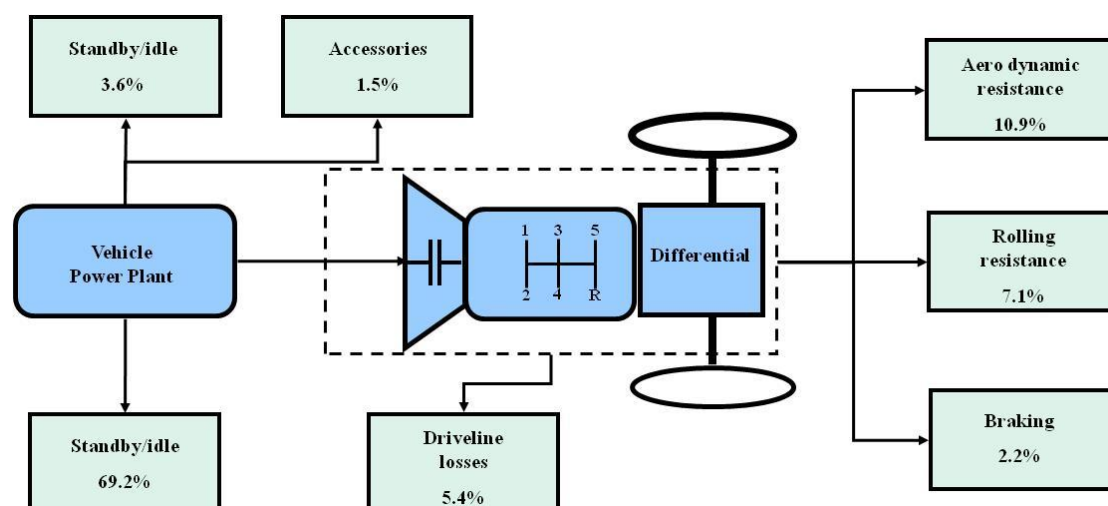

Figure 1: Translation of fuel energy into work in a vehicle

Energy Savings Potential of Hybrid Drivetrains

In terms of overall energy efficiency, the conceptual advantages of a hybrid over a conventional vehicle are:

- **Regenerative braking.** A hybrid can capture some of the energy normally lost as heat to the mechanical brakes by using its electric drive motor(s) in generator mode to brake the vehicle
- **More efficient operation of the ICE, including reduction of idle.** A hybrid can avoid some of the energy losses associated with engine operation at speed and load combinations where the engine is inefficient by using the energy storage device to either absorb part of the ICE's output or augment it or even substitute for it. This allows the ICE to operate only at speeds and loads where it is most efficient. When an HEV is stopped, rather than running the engine at idle, where it is extremely inefficient, the control system may either shut off the engine, with the storage device providing auxiliary power (for heating or cooling the vehicle interior, powering headlights, etc.), or run the engine at a higher-than-idle (more efficient) power setting and use the excess power (over auxiliary loads) to recharge the storage device. When the vehicle control system can shut the engine off at idle, the drivetrain can be designed so that the drive motor also serves as the starter motor, allowing extremely rapid restart due to the motor's high starting torque.
- **Smaller ICE:** Since the storage device can take up a part of the load, the HEV's ICE can be down sized. The ICE may be sized for the continuous load and not for the very high short term acceleration load. This enables the ICE to operate at a higher fraction of its rated power, generally at higher fuel efficiency, during most of the driving.

There are counterbalancing factors reducing hybrids' energy advantage, including:

- **Potential for higher weight.** Although the fuel-driven energy source on a hybrid generally will be of lower power and weight than the engine in a conventional vehicle of similar performance, total hybrid weight is likely to be higher than the conventional vehicle it replaces because of the added weight of the storage device, electric motor(s), and other components. This depends, of course, on the storage mechanism chosen, the vehicle performance requirements, and so forth.

- **Electrical losses.** Although individual electric drivetrain components tend to be quite efficient for one-way energy flows, in many hybrid configurations, electricity flows back and forth through components in a way that leads to cascading losses. Further, some of the components may be forced to operate under conditions where they have reduced efficiency. For example, like ICEs, most electric motors have lower efficiency at the low-speed, low-load conditions often encountered in city driving. Without careful component selection and a control strategy that minimizes electric losses, much of the theoretical efficiency advantage often associated with an electric drivetrain can be lost.

HEV Configurations

In **Figure 2** the generic concept of a hybrid drivetrain and possible energy flow route is shown. The various possible ways of combining the power flow to meet the driving requirements are:

- i. powertrain 1 alone delivers power
- ii. powertrain 2 alone delivers power
- iii. both powertrain 1 and 2 deliver power to load at the same time
- iv. powertrain 2 obtains power from load (regenerative braking)
- v. powertrain 2 obtains power from powertrain 1
- vi. powertrain 2 obtains power from powertrain 1 and load at the same time
- vii. powertrain 1 delivers power simultaneously to load and to powertrain 2
- viii. powertrain 1 delivers power to powertrain 2 and powertrain 2 delivers power to load
- ix. powertrain 1 delivers power to load and load delivers power to powertrain 2.

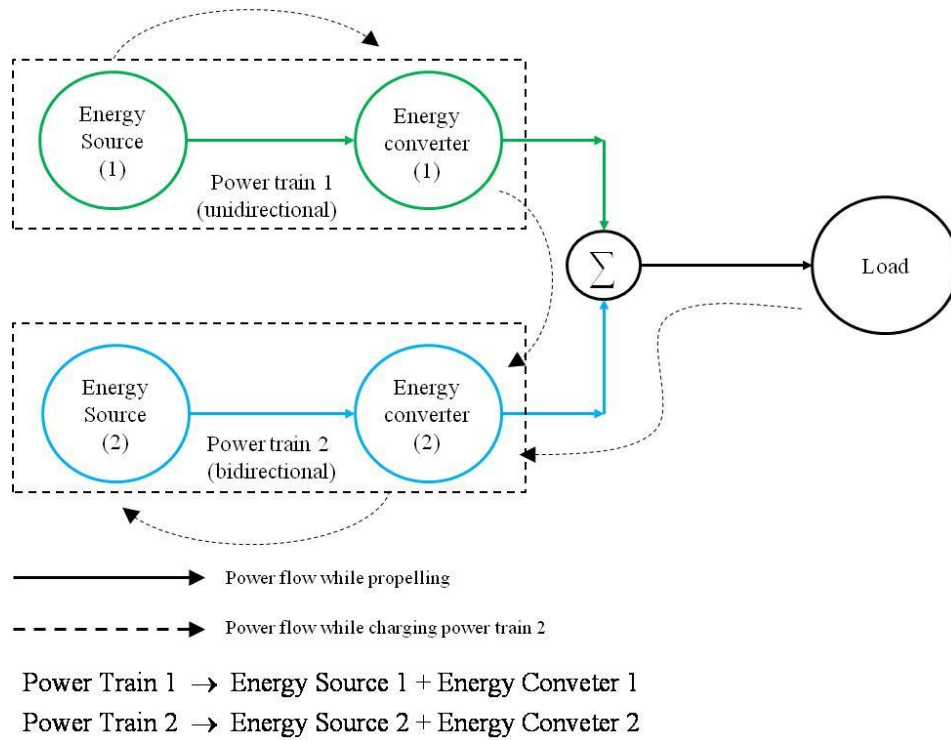

Figure 2: Generic Hybrid Drivetrain [1]

The load power of a vehicle varies randomly in actual operation due to frequent acceleration, deceleration and climbing up and down the grades. The power requirement for a typical driving scenario is shown in **Figure 3**. The load power can be decomposed into two parts:

- i. steady power, i.e. the power with a constant value
- ii. dynamic power, i.e. the power whose average value is zero

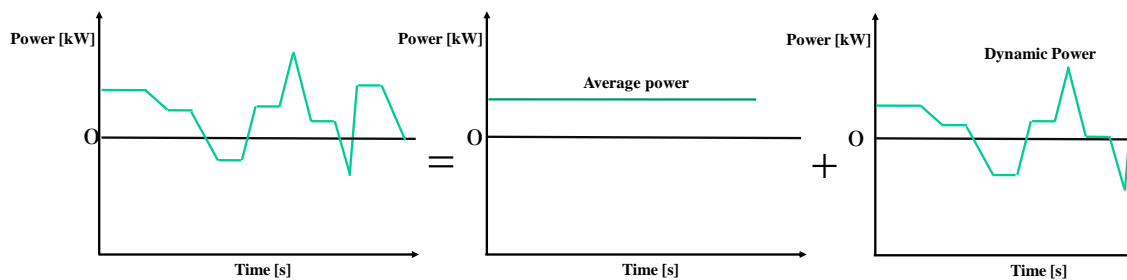

Figure 3: Load power decomposition [1]

In HEV one powertrain favours steady state operation, such as an ICE or fuel cell. The other powertrain in the HEV is used to supply the dynamic power. The total energy output from the dynamic powertrain will be zero in the whole driving cycle. Generally, electric motors are used to meet the dynamic power demand. This hybrid drivetrain concept can be implemented by different configurations as follows:

- Series configuration
- Parallel configuration
- Series-parallel configuration
- Complex configuration

In **Figure 4** the functional block diagrams of the various HEV configurations is shown. From **Figure 4** it can be observed that the key feature of:

- series hybrid is to couple the ICE with the generator to produce electricity for pure electric propulsion.
- parallel hybrid is to couple both the ICE and electric motor with the transmission via the same drive shaft to propel the vehicle

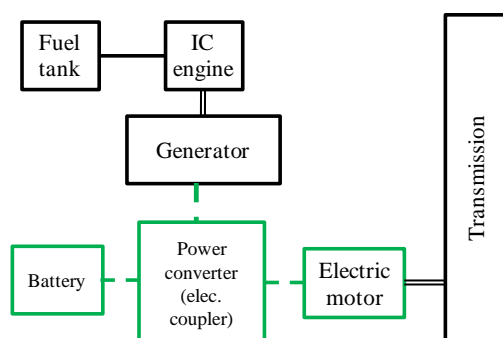

Figure 4a: Series hybrid [1]

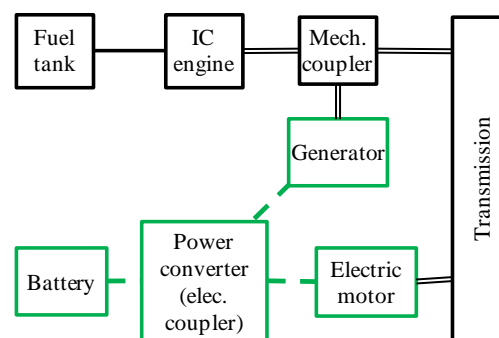

Figure 4b: Series-Parallel hybrid [1]

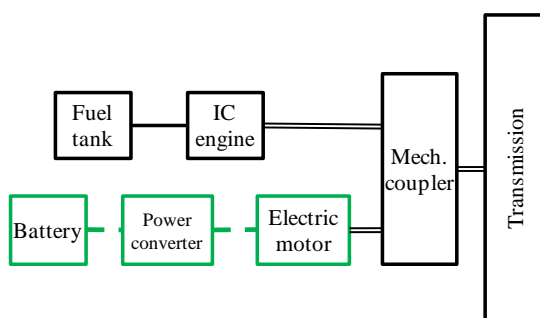

Figure 4c: Parallel hybrid [1]

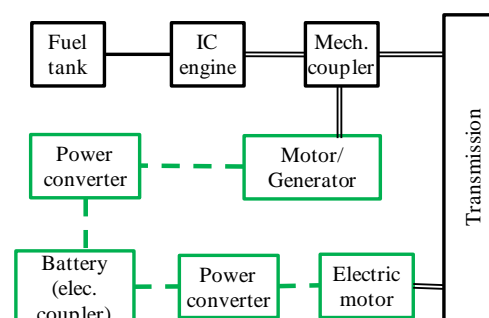

Figure 4d: Complex hybrid [1]

Series Hybrid System:

In case of series hybrid system (**Figure 4a**) the mechanical output is first converted into electricity using a generator. The converted electricity either charges the battery or can bypass the battery to propel the wheels via the motor and mechanical transmission. Conceptually, it is an ICE assisted Electric Vehicle (EV). The advantages of series hybrid drivetrains are:

- mechanical decoupling between the ICE and driven wheels allows the IC engine operating at its very narrow optimal region as shown in **Figure 5**.
- nearly ideal torque-speed characteristics of electric motor make multigear transmission unnecessary.

However, a series hybrid drivetrain has the following disadvantages:

- the energy is converted twice (mechanical to electrical and then to mechanical) and this reduces the overall efficiency.
- Two electric machines are needed and a big traction motor is required because it is the only torque source of the driven wheels.

The series hybrid drivetrain is used in heavy commercial vehicles, military vehicles and buses. The reason is that large vehicles have enough space for the bulky engine/generator system.

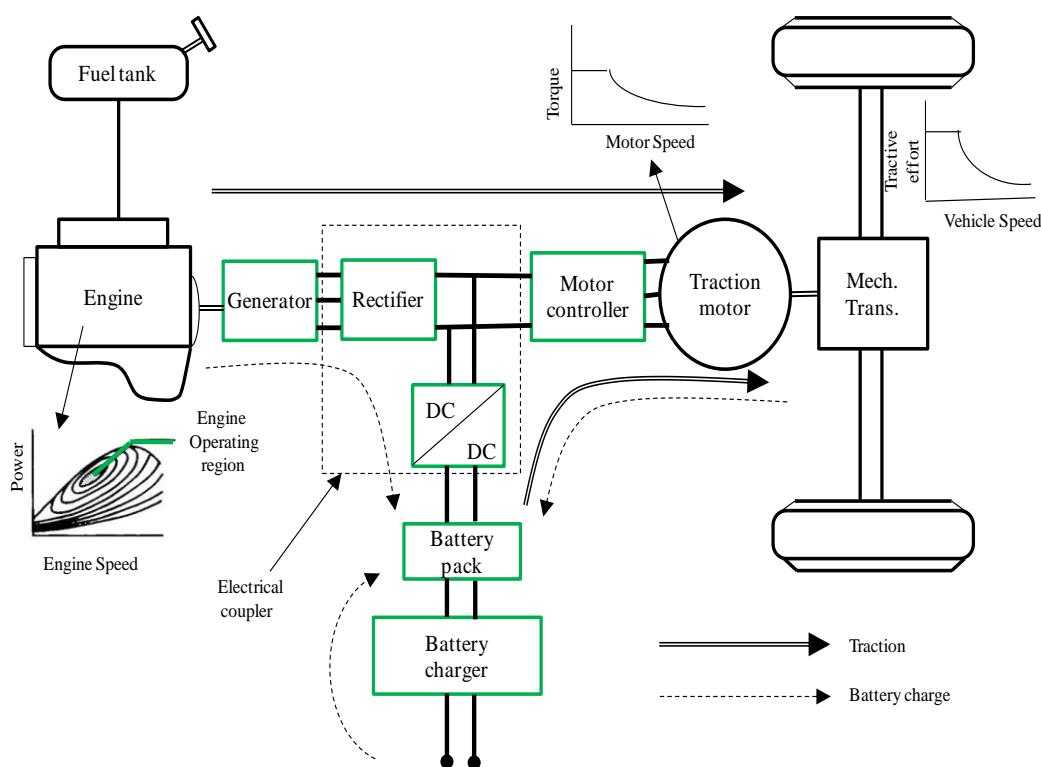

Figure 5: Detailed Configuration of Series Hybrid Vehicle [1]

Parallel Hybrid System:

The parallel HEV (**Figure 4b**) allows both ICE and electric motor (EM) to deliver power to drive the wheels. Since both the ICE and EM are coupled to the drive shaft of the wheels via two clutches, the propulsion power may be supplied by ICE alone, by EM only or by both ICE and EM. The EM can be used as a generator to charge the battery by regenerative braking or absorbing power from the ICE when its output is greater than that required to drive the wheels. The advantages of the parallel hybrid drivetrain are:

- both engine and electric motor directly supply torques to the driven wheels and no energy form conversion occurs, hence energy loss is less
- compactness due to no need of the generator and smaller traction motor.

The drawbacks of parallel hybrid drivetrains are:

- mechanical coupling between the engines and the driven wheels, thus the engine operating points cannot be fixed in a narrow speed region.
- The mechanical configuration and the control strategy are complex compared to series hybrid drivetrain.

Due to its compact characteristics, small vehicles use parallel configuration. Most passenger cars employ this configuration.

Series-Parallel System

In the series-parallel hybrid (**Figure 4c**), the configuration incorporates the features of both the series and parallel HEVs. However, this configuration needs an additional electric machine and a planetary gear unit making the control complex.

Complex Hybrid System

The complex hybrid system (**Figure 4d**) involves a complex configuration which cannot be classified into the above three kinds. The complex hybrid is similar to the series-parallel hybrid since the generator and electric motor is both electric machines. However, the key difference is due to the bi-directional power flow of the electric motor in complex hybrid and the unidirectional power flow of the generator in the series-parallel hybrid. The major disadvantage of complex hybrid is higher complexity.

References:

[1] M. Ehsani, *Modern Electric, Hybrid Electric and Fuel Cell Vehicles: Fundamentals, Theory and Design*, CRC Press, 2005

Suggested Reading:

[1] I. Husain, *Electric and Hybrid Electric Vehicles*, CRC Press, 2003

Lecture 6: Power Flow in HEVs

Power Flow in HEVs

Introduction

The following topics are covered in this lecture

- Power Flow Control
- Power Flow Control in Series Hybrid
- Power Flow Control in Parallel Hybrid
- Power Flow Control in Series-Parallel Hybrid

Power Flow Control

Due to the variations in HEV configurations, different power control strategies are necessary to regulate the power flow to or from different components. All the control strategies aim satisfy the following goals:

- maximum fuel efficiency
- minimum emissions
- minimum system costs
- good driving performance

The design of power control strategies for HEVs involves different considerations such as:

- ***Optimal ICE operating point:*** The optimal operating point on the torque-speed plane of the ICE can be based on maximization of fuel economy, the minimization of emissions or a compromise between fuel economy and emissions.
- ***Optimal ICE operating line:*** In case the ICE needs to deliver different power demands, the corresponding optimal operating points constitute an optimal operating line.
- ***Safe battery voltage:*** The battery voltage may be significantly altered during discharging, generator charging or regenerative charging. This battery voltage should not exceed the maximum voltage limit nor should it fall below the minimum voltage limit.

Power Flow Control in Series Hybrid

In the series hybrid system there are four operating modes based on the power flow:

- **Mode 1:** During startup (**Figure 1a**), normal driving or acceleration of the series HEV, both the ICE and battery deliver electric energy to the power converter which then drives the electric motor and hence the wheels via transmission.
- **Mode 2:** At light load (**Figure 1b**), the ICE output is greater than that required to drive the wheels. Hence, a fraction of the generated electrical energy is used to charge the battery. The charging of the battery takes place till the battery capacity reaches a proper level.
- **Mode 3:** During braking or deceleration (**Figure 1c**), the electric motor acts as a generator, which converts the kinetic energy of the wheels into electricity and this, is used to charge the battery.
- **Mode 4:** The battery can also be charged by the ICE via the generator even when the vehicle comes to a complete stop (**Figure 1d**).

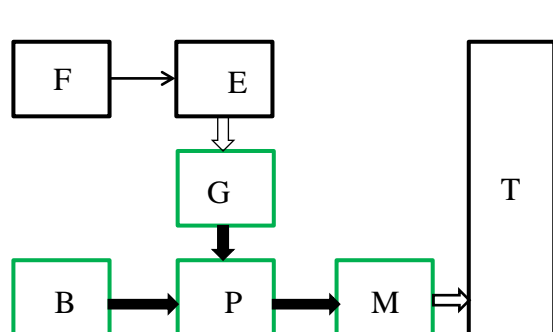

Figure 1a: Mode 1, normal driving or acceleration

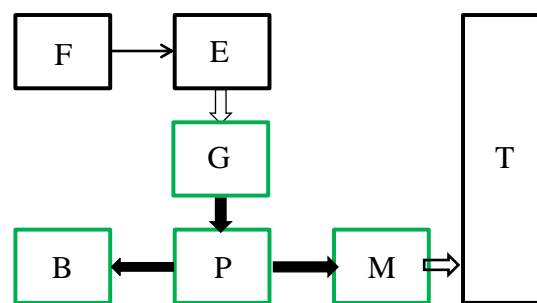

Figure 1b: Mode 2, light load

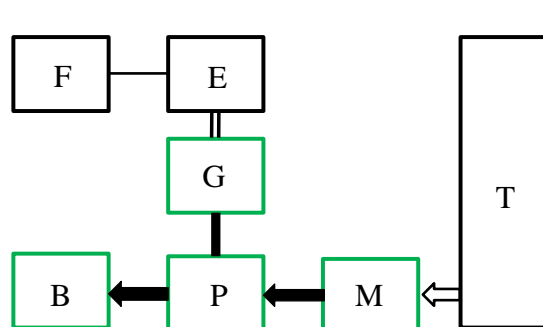

Figure 1c: Mode 3, braking or deceleration [1]

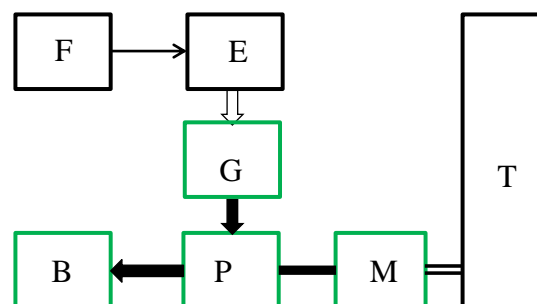

Figure 1d: Mode 4, vehicle at stop

B: Battery	G: Generator	— (thick line)	Electrical link
E: ICE	M: Motor	— (thin line)	Hydraulic link
F: Fuel tank	P: Power Converter	== (double line)	Mechanical link
T: Transmission (including brakes, clutches and gears)			

Power Flow Control in Parallel Hybrid

The parallel hybrid system has four modes of operation. These four modes of operation are

- **Mode 1:** During start up or full throttle acceleration (**Figure 2a**); both the ICE and the EM share the required power to propel the vehicle. Typically, the relative distribution between the ICE and electric motor is 80-20%.
- **Mode 2:** During normal driving (**Figure 2b**), the required traction power is supplied by the ICE only and the EM remains in off mode.
- **Mode 3:** During braking or deceleration (**Figure 2c**), the EM acts as a generator to charge the battery via the power converter.
- **Mode 4:** Under light load condition (**Figure 2d**), the traction power is delivered by the ICE and the ICE also charges the battery via the EM.

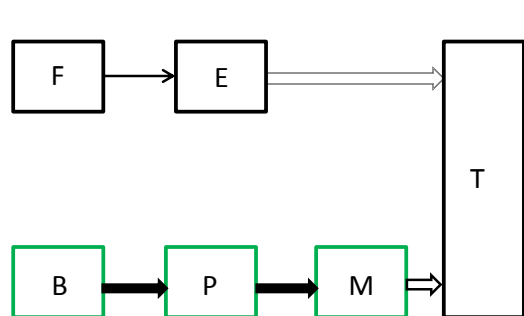

Figure 2a: Mode 1, start up

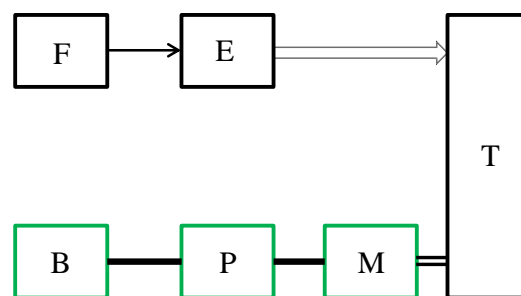

Figure 2b: Mode 2, normal driving

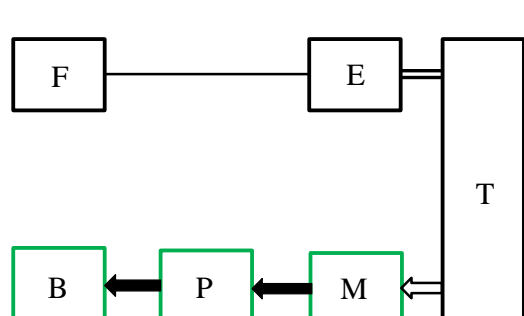

Figure 2c: Mode 3, braking or deceleration [1]

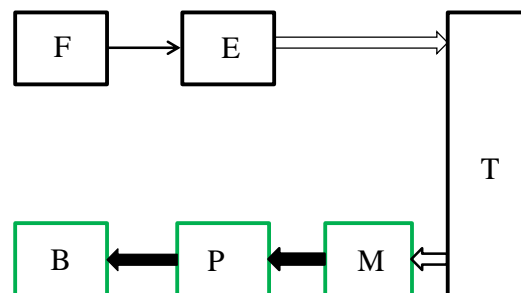

Figure 2d: Mode 4, light load

B: Battery	G: Generator	— (thick)	Electrical link
E: ICE	M: Motor	— (thin)	Hydraulic link
F: Fuel tank	P: Power Converter	== (double)	Mechanical link

T: Transmission (including brakes, clutches and gears)

Power Flow Control Series-Parallel Hybrid

The series-parallel hybrid system involves the features of series and parallel hybrid systems. Hence, a number of operation modes are feasible. Therefore, these hybrid systems are classified into two categories: **the ICE dominated** and the **EM dominated**.

The various operating modes of **ICE dominated** system are:

- **Mode 1:** At startup (**Figure 3a**), the battery solely provides the necessary power to propel the vehicle and the ICE remains in off mode.
- **Mode 2:** During full throttle acceleration (**Figure 3b**), both the ICE and the EM share the required traction power.
- **Mode 3:** During normal driving (**Figure 3c**), the required traction power is provided by the ICE only and the EM remains in the off state.
- **Mode 4:** During normal braking or deceleration (**Figure 3d**), the EM acts as a generator to charge the battery.

- **Mode 5:** To charge the battery during driving (**Figure 3e**), the ICE delivers the required traction power and also charges the battery. In this mode the EM acts as a generator.
- **Mode 6:** When the vehicle is at standstill (**Figure 3f**), the ICE can deliver power to charge the battery via the EM

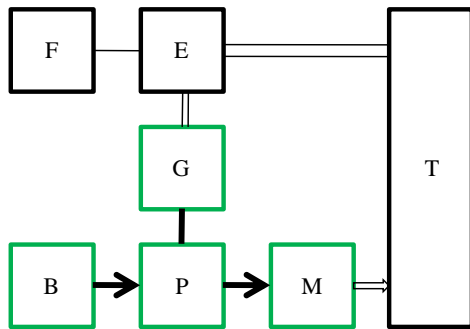

Figure 3a: Mode 1, start up [1]

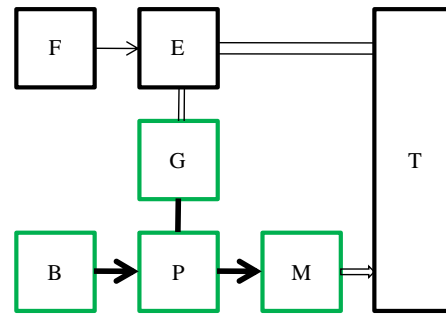

Figure 3b: Mode 2, acceleration [1]

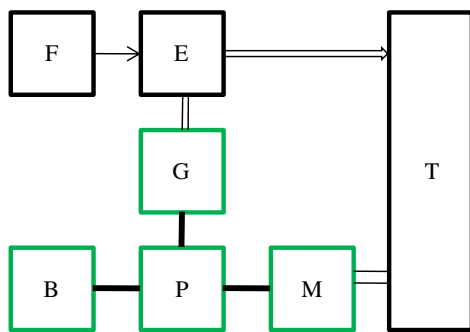

Figure 3c: Mode 3, normal drive [1]

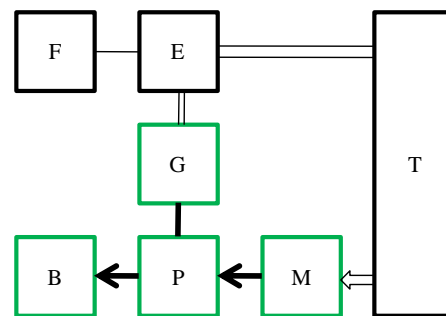

Figure 3d: Mode 4, braking or deceleration [1]

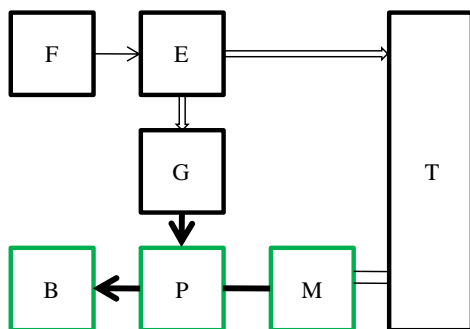

Figure 3e: Mode 5, battery charging during driving [1]

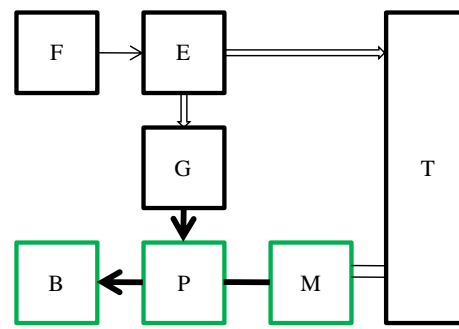

Figure 3f: Mode 6, battery charging during standstill [1]

B : Battery
 E : ICE
 F : Fuel Tank
 G : Generator
 M : Motor
 P : Power Converter
 T : Transmission(including brakes, clutches and gears)

— Electrical link
 — Hydraulic link
 — Mechanical link

The operating modes of **EM dominated** system are:

- **Mode 1:** During startup (**Figure 4a**), the EM provides the traction power and the ICE remains in the off state.
- **Mode 2:** During full throttle (**Figure 4b**), both the ICE and EM provide the traction power.
- **Mode 3:** During normal driving (**Figure 4c**), both the ICE and EM provide the traction power.
- **Mode 4:** During braking or deceleration (**Figure 4d**), the EM acts as a generator to charge the battery.
- **Mode 5:** To charge the battery during driving (**Figure 4e**), the ICE delivers the required traction power and also charges the battery. The EM acts as a generator.
- **Mode 6:** When the vehicle is at standstill (**Figure 4f**), the ICE can deliver power to charge the battery via the EM

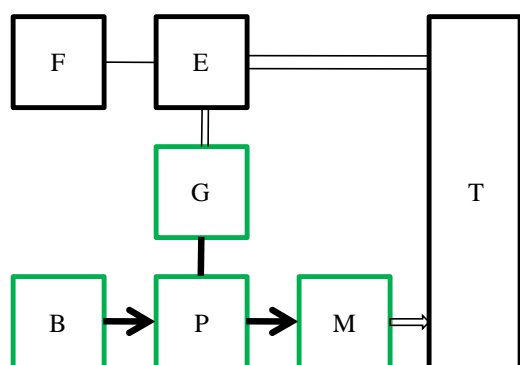

Figure 4a: Mode 1, start up [1]

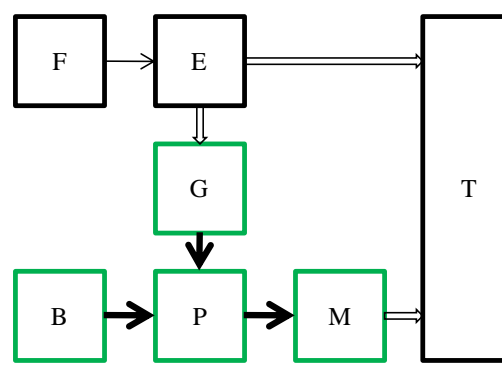

Figure 4b: Mode 2, acceleration [1]

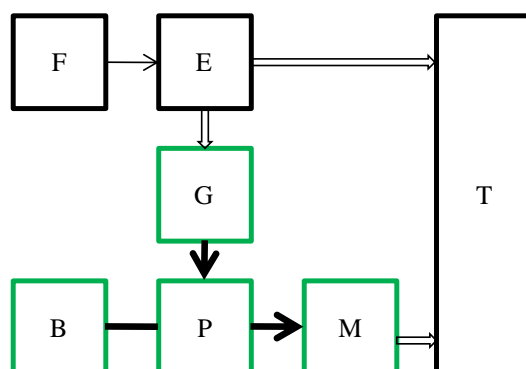

Figure 4c: Mode 3, normal drive [1]

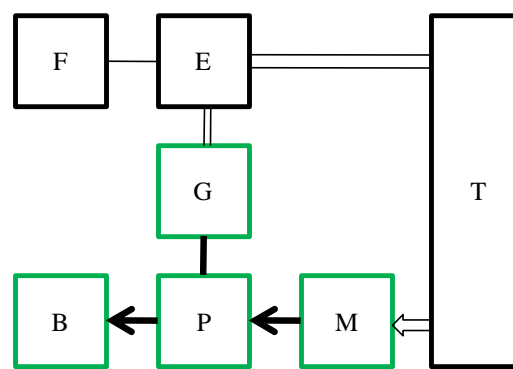

Figure 4d: Mode 4, braking or deceleration [1]

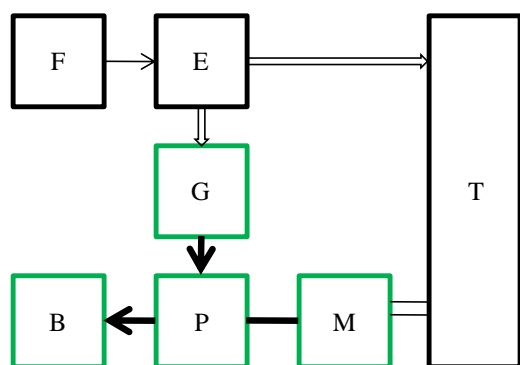

Figure 4e: Mode 5, battery charging during driving [1]

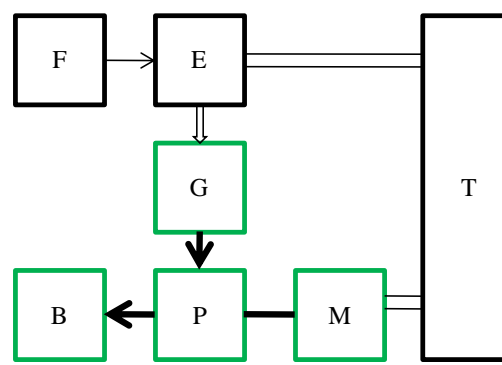

Figure 4f: Mode 6, battery charging during standstill [1]

B : Battery

E : ICE

F : Fuel Tank

G : Generator

M : Motor

P : Power Converter

T : Transmission(including brakes, clutches and gears)

— Electrical link

— Hydraulic link

— Mechanical link

Power Flow Control Complex Hybrid Control

The complex hybrid vehicle configurations are of two types:

- Front hybrid rear electric
- Front electric and rear hybrid

Both the configurations have six modes of operation:

- **Mode 1:** During startup (**Figure 5a**), the required traction power is delivered by the EMs and the engine is in off mode.
- **Mode 2:** During full throttle acceleration (**Figure 5b**), both the ICE and the front wheel EM deliver the power to the front wheel and the second EM delivers power to the rear wheel.
- **Mode 3:** During normal driving (**Figure 5c**), the ICE delivers power to propel the front wheel and to drive the first EM as a generator to charge the battery.
- **Mode 4:** During driving at light load (**Figure 5d**) first EM delivers the required traction power to the front wheel. The second EM and the ICE are in off state.
- **Mode 5:** During braking or deceleration (**Figure 5e**), both the front and rear wheel EMs act as generators to simultaneously charge the battery.

- Mode 6:** A unique operating mode of complex hybrid system is **axial balancing**. In this mode (**Figure 5f**) if the front wheel slips, the front EM works as a generator to absorb the change of ICE power. Through the battery, this power difference is then used to drive the rear wheels to achieve the axle balancing.

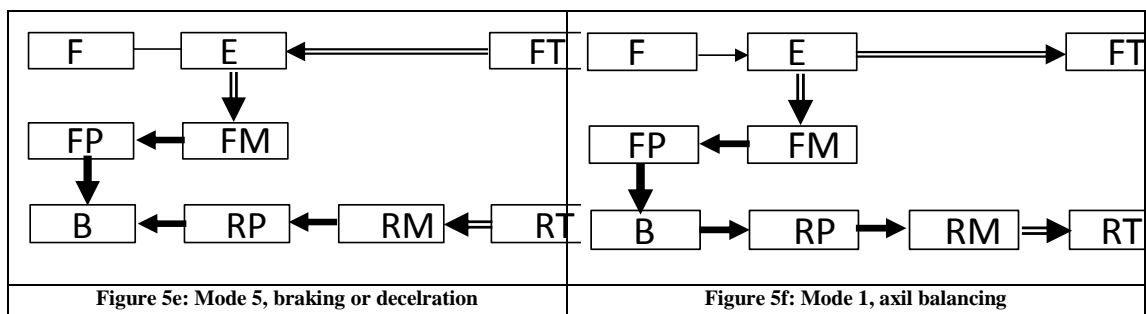
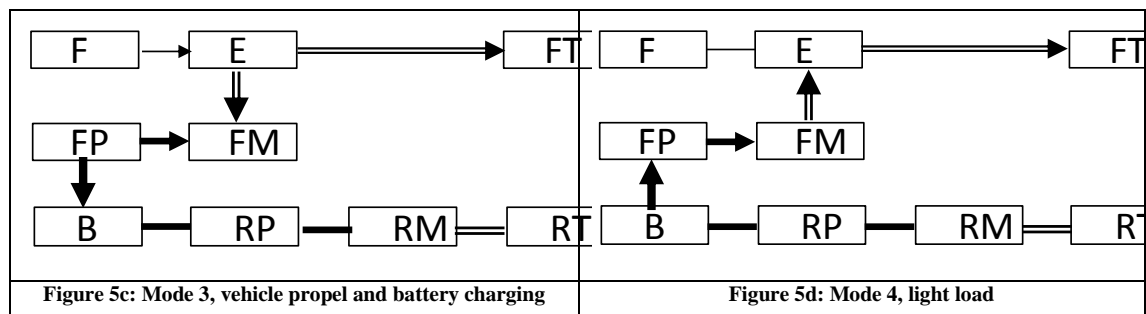
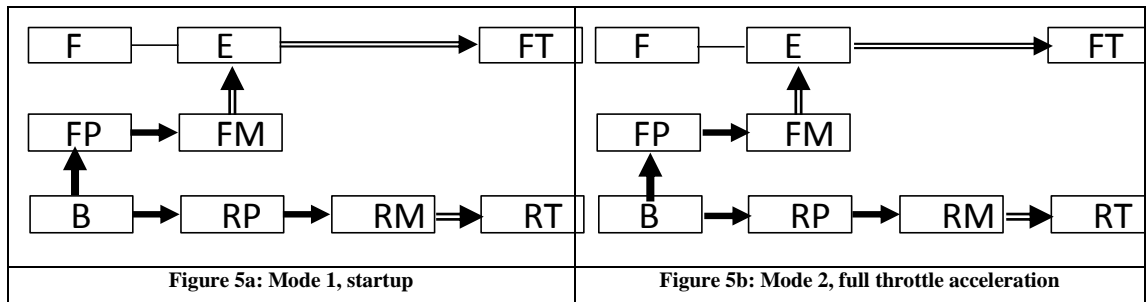

B:Battery **FM:** Front motor **FP:** Front power converter **FT:** Front axel transmission **E:** ICE **F:** Fuel tank
RM: Rear motor **RP:** Rear power converter **RT:** Rear axle transmission [1]

— Electrical link
— Hydraulic link
== Mechanical link

In **Figures 6a-f** all the six modes of operation of front electric and rear hybrid is shown.

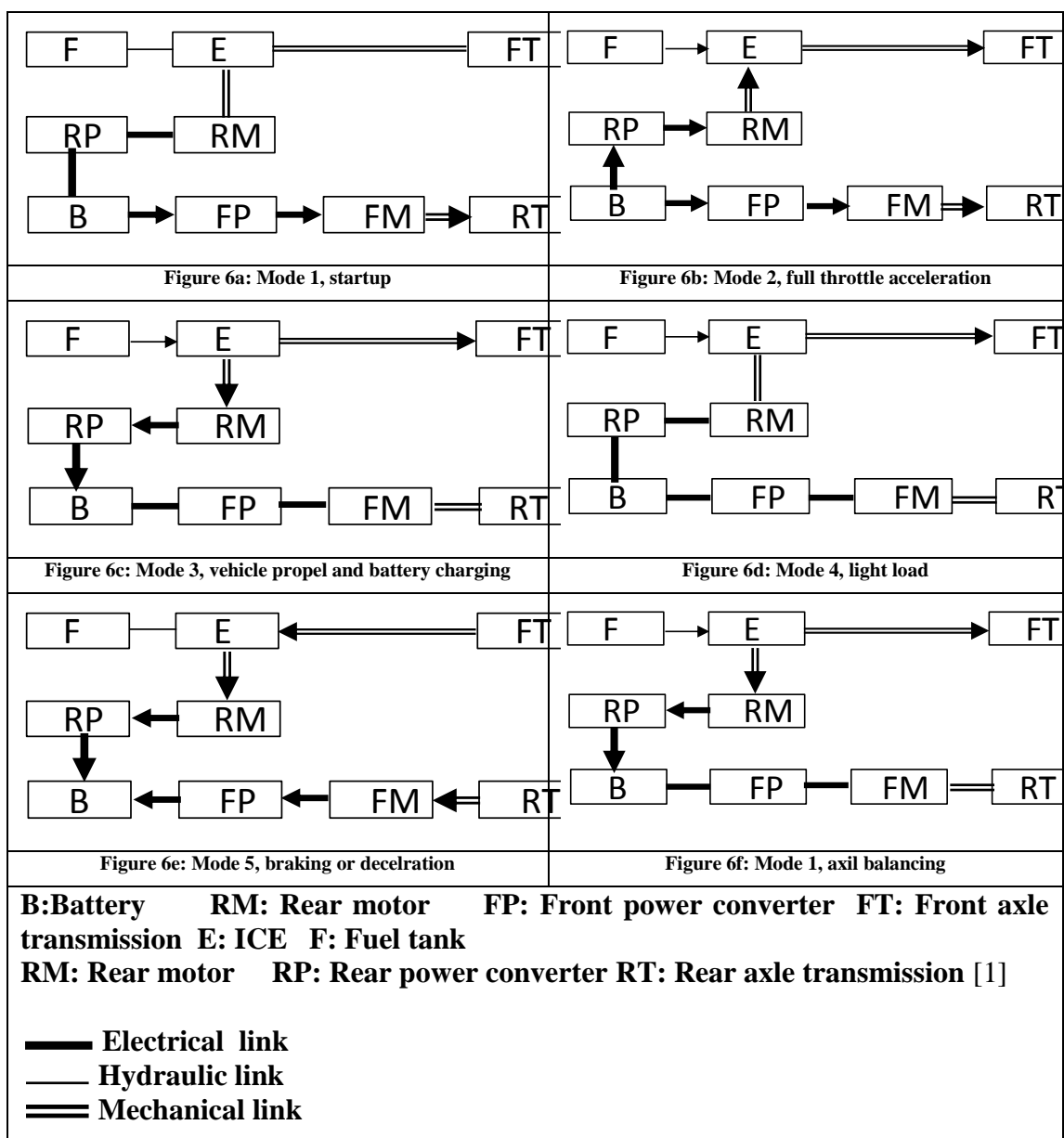

References:

[1] I. Husain, *Electric and Hybrid Electric Vehicles*, CRC Press, 2003

Suggested Reading:

[1] M. Ehsani, *Modern Electric, Hybrid Electric and Fuel Cell Vehicles: Fundamentals, Theory and Design*, CRC Press, 2005

Lecture 7: Torque Coupling and Analysis of Parallel Drive Train

Torque Coupling and Analysis of Parallel Drive Train

Introduction

The topics covered in this chapter are as follows:

- Introduction to Parallel Hybrid Electric Drive Train
- Torque Coupling
- Speed Coupling
- Post-Transmission Parallel Hybrid Drive Train with Torque Coupling
- Pre-Transmission Parallel Hybrid Drive Train with Torque Coupling
- Parallel Hybrid Drive Train with Speed Coupling
- Complex Hybrid Drivetrain

Parallel Hybrid Electric Drive Trains

In case of parallel hybrid drivetrains, the ICE and an electric motor (EM) supply the required traction power. The power from ICE and EM are added together by a mechanical coupler, **Figure 1**. Generally, the mechanical coupling is of two types:

- **Torque coupling:** In this case the coupler adds the torques of the ICE and EM together and delivers the total torque to the driven wheels. The ICE and EM torque can be independently controlled. The speeds of the ICE, EM and the vehicle are linked together with a fixed relationship and cannot be independently controlled because of the power conservation constraint.
- **Speed coupling:** In this case the speeds of the ICE and EM can be added together and all torques are linked together and cannot be independently controlled.

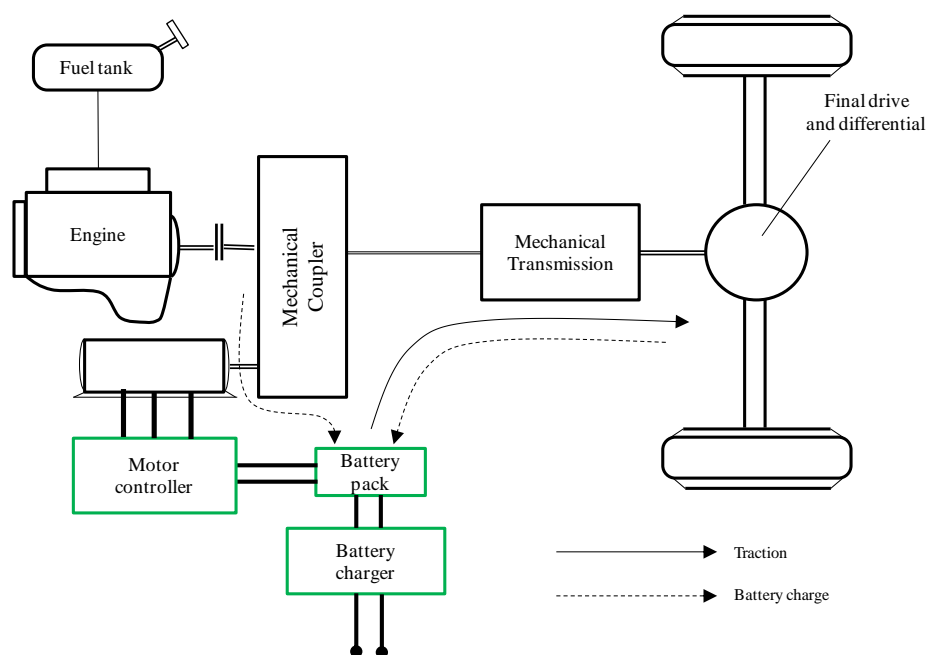

Figure 1: General Configuration of a Parallel Hybrid Drive Train [1]

Torque Coupling

In **Figure 2**, a conceptual diagram of mechanical torque coupling is shown. The torque coupling, shown in **Figure 2**, is a two-degree-of-freedom mechanical device. Port 1 is a unidirectional input and Port 2 and 3 are bi-directional input or output, but both are not input at the same time. Here input means the energy flows into the device and output means the energy flows out of the device. In case of HEV

- **port 1** is connected to the shaft of an **ICE** directly or through a mechanical transmission.
- **port 2** is connected to the shaft of an **electric motor** directly or through a mechanical transmission
- **port 3** is connected to the driven **wheels** through a mechanical linkage

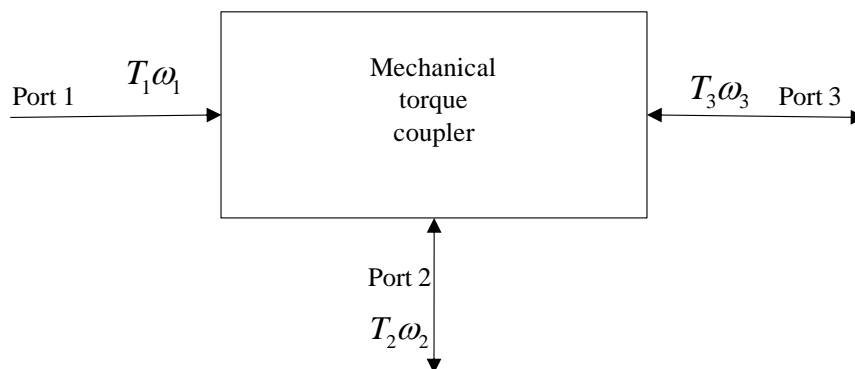

Figure 2: Mechanical torque coupler [2]

For a *losses* torque coupler in *steady state*, the power input is always equal to the power output from it. For the torque coupler shown in **Figure 1**, the power balance is

$$T_3\omega_3 = T_1\omega_1 + T_2\omega_2$$

where

$$T_1 = \text{Propelling torque produced by ICE}; \quad \omega_1 = \text{Speed of ICE} \tag{1}$$

$$T_2 = \text{Propelling torque produced by EM}; \quad \omega_2 = \text{Speed of EM}$$

$$T_3 = \text{Load torque delivered to wheels}; \quad \omega_3 = \text{Speed of wheel}$$

The torque coupler can be expressed as

$$T_3 = k_1T_1 + k_2T_2$$

where (2)

k_1, k_2 are the structural parameters of the torque coupler

From **equation 1** and **equation 2** it can be seen that

$$\omega_3 = \frac{\omega_1}{k_1} = \frac{\omega_2}{k_2} \tag{3}$$

A gearbox used in the vehicles is a typical example of torque couple. Some torque coupler are shown in **Figure 3**

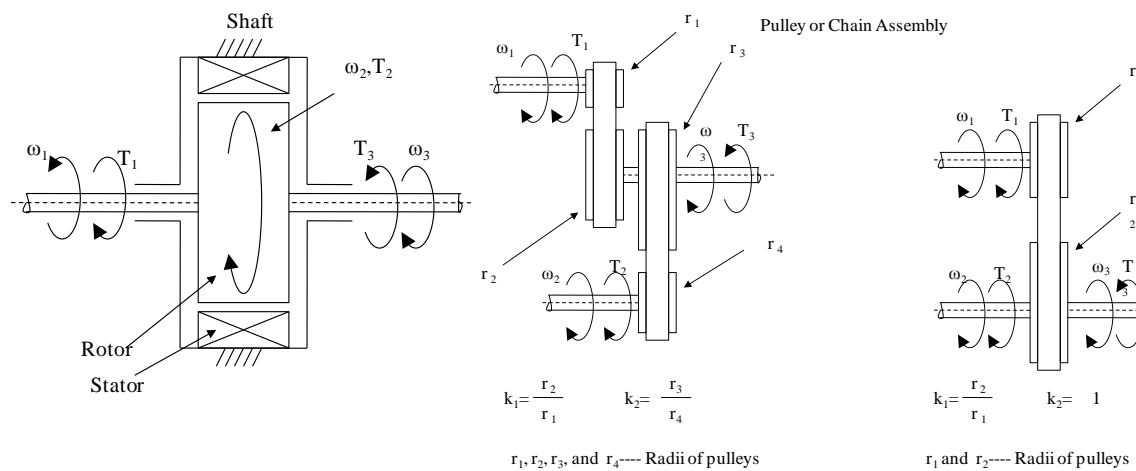

Figure 3a: Configuration of a torque coupler [2]

Figure 3b: Configuration of a pulley/chain assembly torque coupler [2]

Speed Coupling

The power produced by two power plants may be coupled together by adding their speed. This is done with the help of **speed coupling** devices (**Figure 4**). The Speed Coupler is a three port two-degree-of-freedom device. Port 1 is a unidirectional input and Port 2 and 3 are bi-directional input or output, but both are not input at the same time. Here input means the energy flows into the device and output means the energy flows out of the device. In case of HEV

- **port 1** is connected to the shaft of an **ICE** directly or through a mechanical transmission.
- **port 2** is connected to the shaft of an **electric motor** directly or through a mechanical transmission
- **port 3** is connected to the driven **wheels** through a mechanical linkage

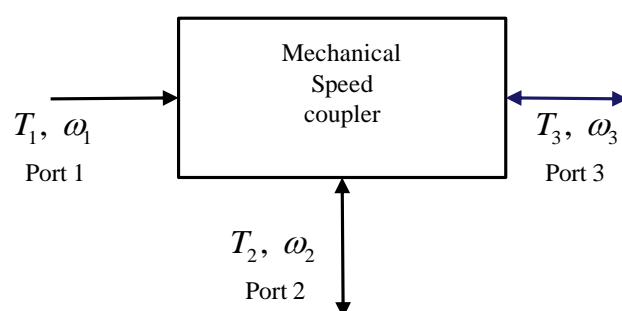

Figure 4: Mechanical speed coupler [2]

For a *losses* speed coupler in *steady state*, the power input is always equal to the power output from it. For the speed coupler shown in **Figure 4**, the speed relation is

$$\omega_3 = k_1\omega_1 + k_2\omega_2 \quad (4)$$

where

k_1, k_2 are the structural parameters of the speed coupler

The power relation in case of speed coupler is same as given in **equation 1**. From **equation 1** and **equation 4** it can be seen that

$$T_3 = \frac{T_1}{k_1} = \frac{T_2}{k_2} \quad (5)$$

A typical speed coupler is the planetary gear (**Figure 5**). The planetary gear unit is a three port device consisting of

- Sun gear, marked **1** in **Figure 5**
- Ring gear, marked **2** in **Figure 5**
- Carrier or Yoke, marked **3** in **Figure 5**

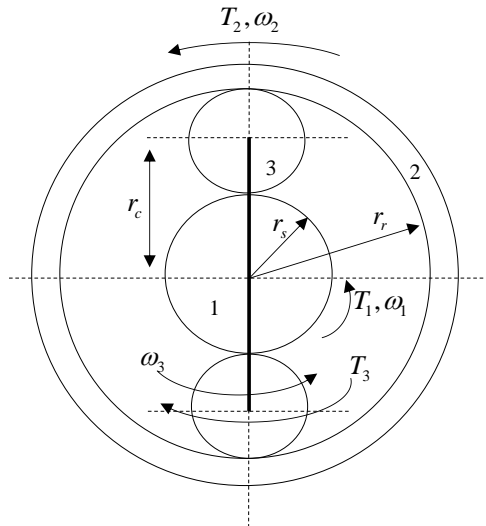

Figure 5a: Planetary gear front view [2]

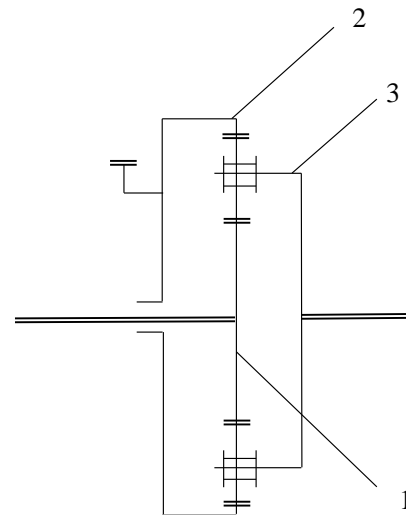

Figure 5b: Planetary gear cut section [2]

For a planetary gear train configuration as shown in **Figure 5**, the gear ratio (n_b) is given by

$$n_b = \frac{\omega_s - \omega_c}{\omega_r - \omega_c} = -\frac{z_r z_c}{z_c z_s} = -\frac{z_r}{z_s} = -\frac{r_r}{r_s}$$

where

ω_s = angular speed of the sun gear

ω_c = angular speed of the carrier gear

ω_r = angular speed of the ring gear

z_s = number of teeth on the sun gear

z_r = number of teeth on the ring gear

z_c = number of teeth on the carrier gear

r_s = radius of the sun gear

r_r = radius of the ring gear

r_c = radius of the carrier gear

(6)

The **equation 6** can also be expressed as

$$\begin{aligned}
 n_b(\omega_r - \omega_c) &= \omega_s - \omega_c \\
 \Rightarrow \omega_s - n_b\omega_r - \omega_c(1 - n_b) &= 0 \\
 \Rightarrow \omega_c &= \frac{1}{1 - n_b}\omega_s - \frac{n_b}{1 - n_b}\omega_r
 \end{aligned} \tag{7}$$

In the analysis of the planetary gears, rotation and torque in the anticlockwise direction is assumed to be positive and in the clockwise direction is assumed to be negative. Using the power balance, the torque acting on each gear is obtained as

$$T_s\omega_s + T_c\omega_c + T_r\omega_r = 0 \tag{8}$$

Substituting the value of ω_c from **equation 7** into **equation 8** gives

$$\begin{aligned}
 T_s\omega_s + T_c\left(\frac{\omega_s}{1 - n_b} - \frac{n_b}{1 - n_b}\omega_r\right) + T_r\omega_r &= 0 \\
 \Rightarrow \omega_s\left(T_s + \frac{1}{1 - n_b}T_c\right) + \omega_r\left(T_r - \frac{n_b}{1 - n_b}T_c\right) &= 0 \\
 T_c = -(1 - n_b)T_s \text{ and } T_c = \frac{1 - n_b}{n_b}T_r
 \end{aligned} \tag{9}$$

If the carrier is attached to a stationary frame ($\omega_c = 0$) then from **equation 7**

$$n_b = \frac{\omega_s}{\omega_r} = -\frac{z_r}{z_s} = -\frac{r_r}{r_s} \tag{10}$$

and from **equation 8** the torque relation is given by

$$\begin{aligned}
 T_s &= -\frac{\omega_r}{\omega_s}T_r \\
 \Rightarrow T_s &= -\frac{T_r}{n_b}
 \end{aligned} \tag{11}$$

From **Figure 5** it can be seen that $r_r > r_s$, hence $|n_b| > 1$. If it is assumed that the input torque is given to the sun gear and the output shaft is connected to the ring gear, then from **equation 10** and **equation 11** it can be deduced that

- The output torque (T_r) is increased by a factor n_b and the direction of the output torque is same as that of the input torque (T_s)
- The output speed (ω_r) is reduced by a factor of n_b and the direction of speed is reversed with respect to the input speed (ω_s).

In **Table 1** all the six possible scenarios of planetary gears are summarized.

Table 1: Planetary gear operation scenarios

Sun gear	Carrier gear	Ring gear	Output Speed	Output Torque	Output speed direction	Output speed magnitude	Output torque direction	Output torque magnitude
Input	Output	Held	$\omega_r = \frac{\omega_s}{n_b}$	$T_r = -n_b T_s$	Reverse	Decreases	Remains same	Increases
Held	Output	Input	$\omega_c = -\frac{n_b}{1-n_b} \omega_r$	$T_c = \frac{1-n_b}{n_b} T_r$	Remains same	Decreases	Reverse	Increases
Output	Input	Held	$\omega_s = (1-n_b) \omega_c$	$T_s = -\frac{T_c}{(1-n_b)}$	Remains same	Increases	Reverse	Decreases
Held	Input	Output	$\omega_r = -\frac{1-n_b}{n_b} \omega_c$	$T_r = \frac{n_b}{1-n_b} T_c$	Remains same	Increases	Reverse	Decreases
Input	Held	Output	$\omega_r = \frac{\omega_s}{n_b}$	$T_r = -n_b T_s$	Reverse	Decreases	Remains same	Increases
Output	Held	Input	$\omega_s = n_b \omega_r$	$T_s = -\frac{T_r}{n_b}$	Reverse	Increases	Remains same	Decreases

Parallel Hybrid Drive Train with Torque Coupling (Post-transmission)

In **Figure 6** a two-shaft configuration of parallel HEV using torque coupler is shown.

In this case two transmissions are used:

- Transmission 1 is between the ICE and the torque coupler
- Transmission 2 is between the EM and the torque coupler

Both the transmissions (**Transmission 1** and **Transmission 2**) may be single geared or multigear. The possible configurations are:

- **Configuration 1:** Both, **Transmission 1** and **Transmission 2** are multigear. The tractive effort vs. speed profile is shown in **Figure 7a**.
- **Configuration 2:** **Transmission 1** is multigear and **Transmission 2** is single geared (**Figure 7b**)
- **Configuration 3:** **Transmission 1** is single geared and **Transmission 2** is multigear (**Figure 7c**)

- **Configuration 4:** Both, *Transmission 1* and *Transmission 2* are single geared (Figure 7d)

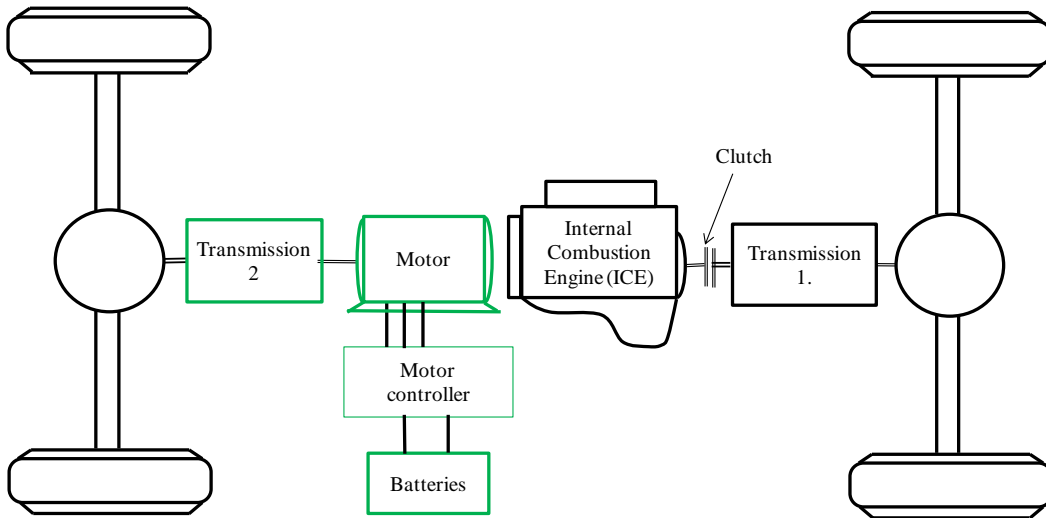

Figure 6: Dual transmission parallel hybrid drivetrain [3]

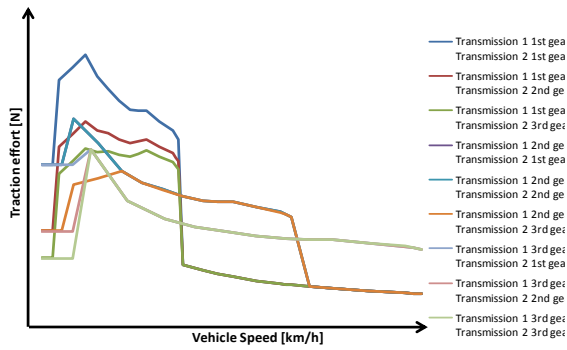

Figure 7a: Transmission 1 and Transmission 2 are multigear [3]

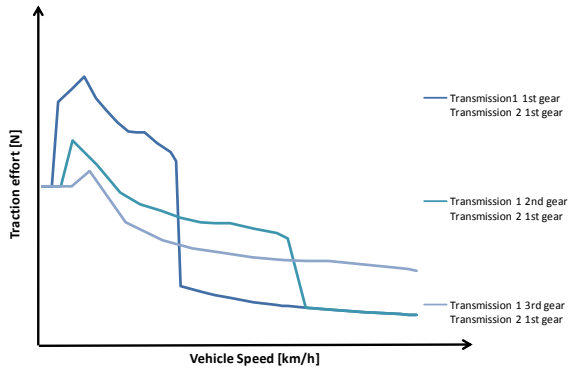

Figure 7b: Transmission 1 is multigear and Transmission 2 is single geared [3]

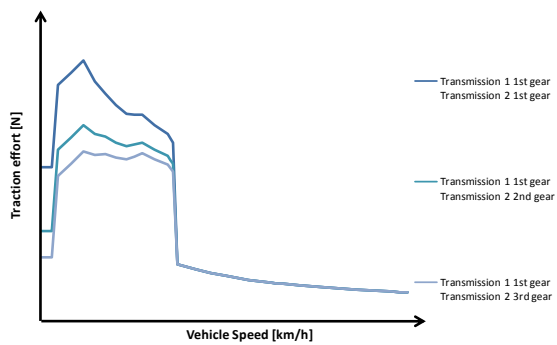

Figure 7c: Transmission 1 is single geared and Transmission 2 is multigear [3]

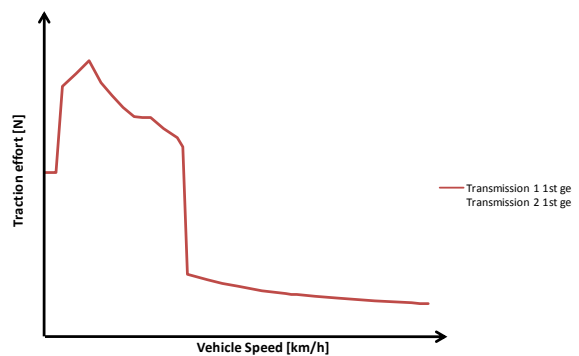

Figure 7d: Transmission 1 and Transmission 2 are single geared [3]

Upon analyzing the tractive effort vs. speed profile of **Configuration 1** it can be concluded that:

- Two multigear transmissions produce many tractive effort profiles. Hence, the performance and overall efficiency of the drive train may be superior to other designs because two multigear transmissions provide more opportunities for both the ICE and the EM-drive (electric motor and the associated power electronics) to operate in their optimum region.
- This configuration provides more opportunities for both the ICE and EM characteristics.
- The control system for selecting the proper gear in each transmission is complicated.

The analysis of **Configuration 2** reveals that

- The multigear *Transmission 1* is used to overcome the disadvantage of the ICE speed vs. torque characteristics.
- The multigear *Transmission 1* also improves the operating efficiency of the engine and reduces the speed range of the vehicle in which EM must be used to propel the vehicle. Hence, the use of EM is restricted and this prevents the batteries from quickly discharging.
- The single gear *Transmission 2* takes the advantage of the high torque of an EM at low speed.

The **Configuration 3** is unfavorable because it does not use the advantages of the two power plants. The **Configuration 4** results in a simple design and control. With proper ratings of the ICE, EM, batteries and transmission parameters, this drivetrain can serve the vehicle with satisfactory performance and efficiency.

Parallel Hybrid Drive Train with Torque Coupling (Pre-transmission)

The pre-transmission configuration of a parallel HEV with torque coupling is shown in **Figure 8**. In this configuration the transmission is located between the torque coupler and the drive shaft. The transmission amplifies the torques of both the ICE and the EM with the same scale. The design of the gear ratios in the torque coupler enables the EM and ICE to reach their maximum speeds at the same time. This configuration is suitable when relatively small EM and ICE are used, where a multigear transmission is needed to enhance the tractive effort at low speeds.

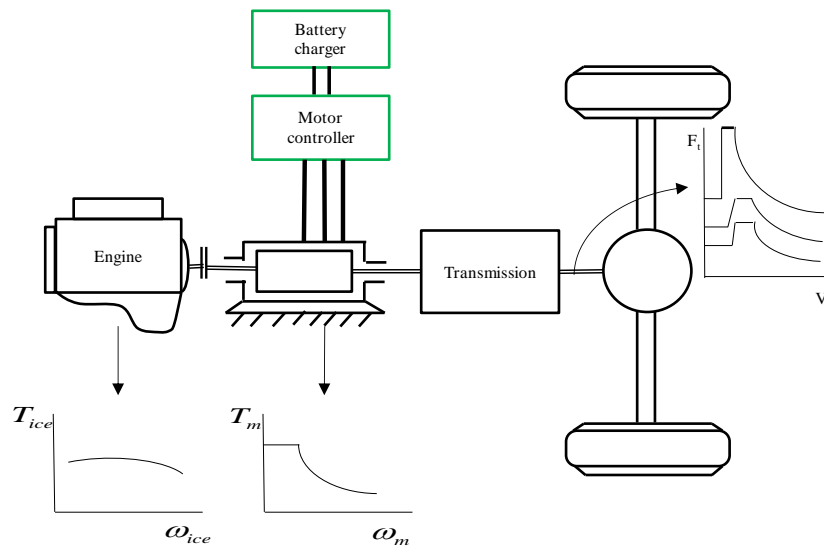

Figure 8: Pre transmission parallel hybrid drive [3]

Parallel Hybrid Drive Train with Speed Coupling

In **Figure 9** a parallel hybrid drive train with speed coupling using planetary gear unit and an EM. The connection of the ICE and the EM is as follows:

- The engine supplies its power to the sun gear through a clutch and transmission. The transmission is used to modify the speed vs. torque profile of the ICE so as to match the traction requirements. The transmission may be single gear or multigear.
- The EM supplies its power to the ring gear through a pair of gears. The Locks 1 and 2 are used to lock the sun gear and ring gear to the stationary frame of the vehicle in order to implement different modes of operation.

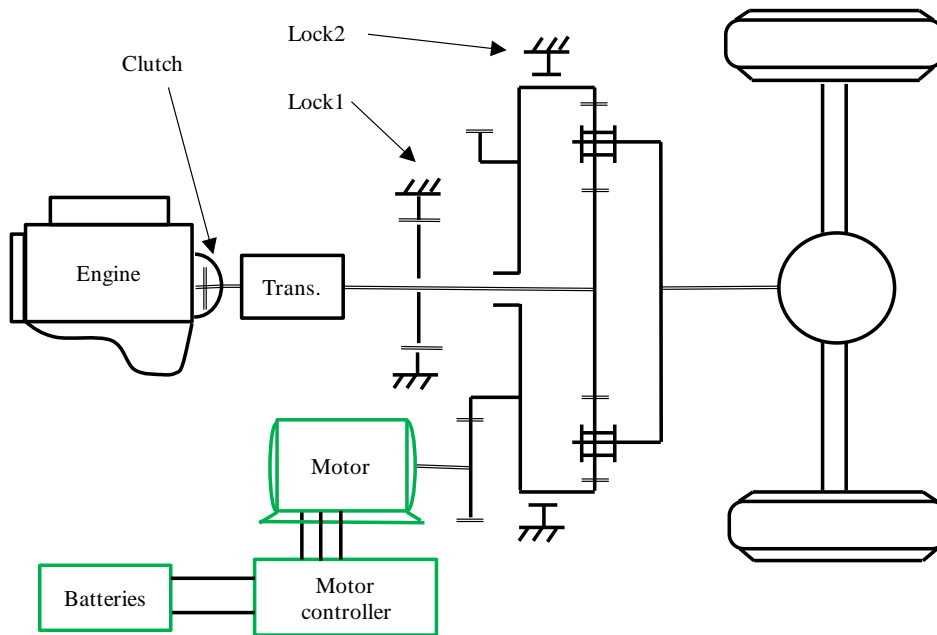

Figure 9: Parallel hybrid drive with speed coupling [1]

There are 5 different modes of operation possible for the configuration as shown in **Figure 10** and they are:

- **Hybrid traction:** When lock 1 and lock 2 are released, i.e. the sun gear and the ring gear can rotate both the ICE and EM supply positive speed and torque to the driven wheels. Since, the output shaft is connected to the carrier gear, the output torque and speed is give by

$$T_c = (n_b - 1) \frac{T_s \omega_s + T_r \omega_r}{\omega_r n_b - \omega_s} \tag{12}$$

$$\omega_c = \frac{1}{1 - n_b} \omega_s - \frac{n_b}{1 - n_b} \omega_r \tag{13}$$

- **Engine alone traction:** When the lock 2 locks the ring gear, only the ICE delivers the required traction force to the wheels. The output torque and the speed is given by

$$T_c = (1 - n_b) T_s \quad (14)$$

$$\omega_c = \frac{1}{1 - n_b} \omega_s \quad (15)$$

- **Motor alone traction:** When lock 1 locks the sun gear, only the EM delivers the traction force to the wheels. The output torque and the speed is given by

$$T_c = \frac{1 - n_b}{n_b} T_r \quad (16)$$

$$\omega_c = -\frac{n_b}{1 - n_b} \omega_r \quad (17)$$

- **Regenerative braking:** In this case lock 2 is engaged, the ICE is switched off, the clutch is disengaged and the EM is controlled in regenerating mode and the battery absorbs the kinetic energy of the vehicle.
- **Battery charging from the ICE:** In this mode the locks 1 and 2 are released. The EM is controlled to rotate in the opposite direction, i.e. the EM operates with positive torque and negative speed and absorbs power from the engine and delivers it to the battery.

Complex Hybrid Drive Train Drivetrain

In **Figure 10**, a complex HEV drivetrain with both torque and speed coupling is shown. This architecture is used by Toyota Prius. The main components of Prius drivetrain are

- **Planetary gear unit:** Used for speed coupling
- **Fixed Axle Gear:** Used for torque coupling

The various power sources of Prius drivetrain are connected as follows:

- The ICE is connected to the carrier gear of the planetary
- A small EM (EM1) is connected to the sun gear
- The ring gear is connected to the driven wheels through axle fixed gear unit (torque coupler)
- An EM (EM2) is also connected to the fixed angle axle gear unit and forms the torque coupling configuration.

The rotational speed of the ring gear is given by

$$\omega_r = \frac{1}{n_b} \omega_s - \frac{1-n_b}{n_b} \omega_c \tag{18}$$

Since the ICE is connected to the carrier gear and the EM1 is connected to the sun gear, the **equation 18** can be expressed as

$$\omega_r = \frac{1}{n_b} \omega_{ICE} - \frac{1-n_b}{n_b} \omega_{EM1} \tag{19}$$

where

ω_{ICE} = angular speed of the ICE

ω_{EM1} = angular speed of the EM1

The various modes of operation are:

- **Mode 1:** When the vehicle speed is low and the ICE speed is not so low then EM1 rotates in the positive direction (same direction as ICE). In this condition, the EM1 operates in generation mode and a fraction of ICE power is used to charge the battery.
- **Mode 2:** At higher vehicle speed, while trying to maintain the engine speed below a given speed, for high engine operating efficiency, the EM1 may be operated in negative speed. In this case EM1 acts as a motor and delivers power to propel the vehicle.

The traction motor EM2 adds additional torque to the torque output from the ring gear of the planetary gear unit using torque coupling device.

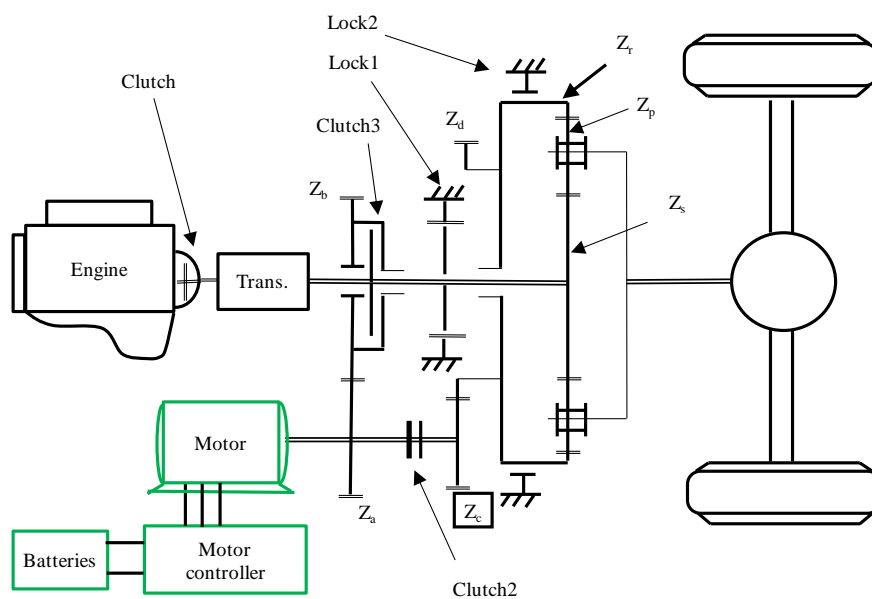

Figure 10: Complex hybrid drive with speed and torque coupling [1]

References

- [1] M. Ehsani, *Modern Electric, Hybrid Electric and Fuel Cell Vehicles: Fundamentals, Theory and Design*, CRC Press, 2005
- [2] L. Guzzella and A. Sciarretta, *Vehicle Propulsion Systems: Introduction to Modeling and Optimization*, Springer, 2007
- [3] G. Lechner and H. Naunheimer, *Automotive Transmissions: Fundamentals, Selection, Design and Application*, Springer, 1999

Lecture 8: Basic Architecture of Electric Drive Trains

Basic Architecture of Electric Drive Trains

Introduction

The topics covered in this chapter are as follows:

- Electric Vehicle (EV) Configuration
- EV alternatives based on drivetrains
- EV alternatives based on power source configuration
- Single and Multi-motor drives
- In wheel drives

Electric Vehicle (EV) Configurations

Compared to HEV, the configuration of EV is flexible. The reasons for this flexibility are:

- The energy flow in EV is mainly via flexible electrical wires rather than bolted flanges or rigid shafts. Hence, distributed subsystems in the EV are really achievable.
- The EVs allow different propulsion arrangements such as independent four wheels and in wheel drives.

In **Figure 1** the general configuration of the EV is shown. The EV has three major subsystems:

- Electric propulsion
- Energy source
- Auxiliary system

The electric propulsion subsystem comprises of:

- The electronic controller
- Power converter
- Electric Motor (EM)
- Mechanical transmission
- Driving wheels

The energy source subsystem consists of

- The energy source (battery, fuel cell, ultracapacitor)
- Energy management unit
- Energy refueling unit

The auxiliary subsystem consists of

- Power steering unit
- Temperature control unit
- Auxiliary power supply

In **Figure 1** the black line represents the mechanical link, the green line represents the electrical link and the blue line represents the control information communication. Based on the control inputs from the brake and accelerator pedals, the electronic controller provides proper control signals to switch on or off the power converter which in turn regulates the power flow between the electric motor and the energy source. The backward power flow is due to regenerative braking of the EV and this regenerative energy can be stored provided the energy source is receptive.

The energy management unit cooperates with the electronic controller to control regenerative braking and its energy recovery. It also works with the energy-refueling unit to control refueling and to monitor usability of the energy source.

The auxiliary power supply provides the necessary power with different voltage levels for all EV auxiliaries, especially the temperature control and power steering units.

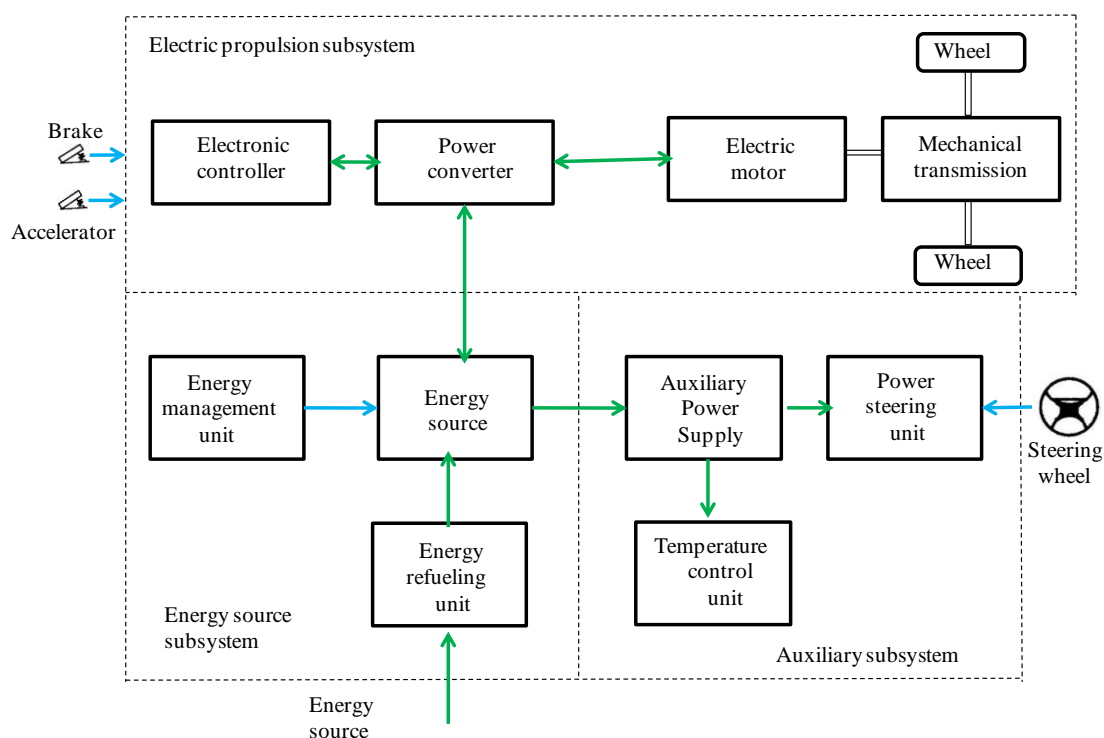

Figure 1: General Configuration of a Electric Vehicle [1]

In modern EV's configuration:

- Three phase motors are generally used to provide the traction force
- The power converter is a three-phase PWM inverter
- Mechanical transmission is based on fixed gearing and a differential
- Li-ion battery is typically selected as the energy source

The typical setup of the EV is shown in **Figure 2**.

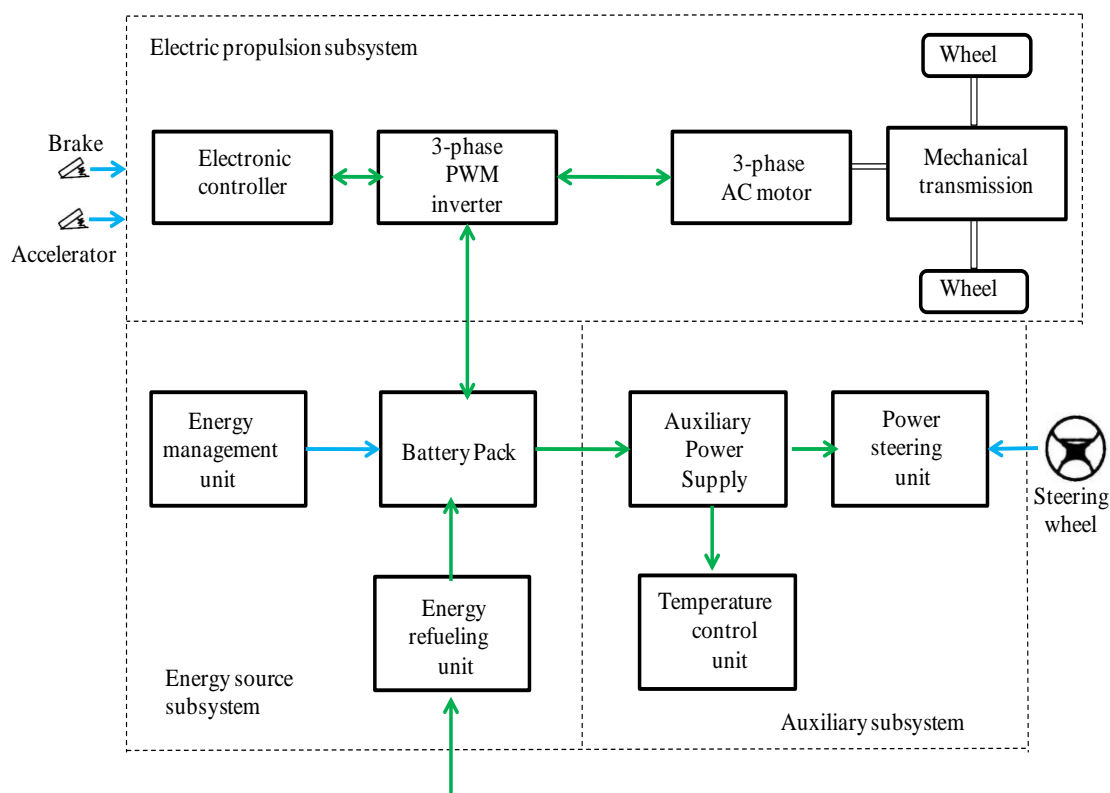

Figure 2: Typical Configuration of a Electric Vehicle [1]

Electric Vehicle (EV) Drivetrain Alternatives Based on Drivetrain Configuration

There are many possible EV configurations due the variations in electric propulsion and energy sources. Based on these variations, six alternatives are possible as shown in **Figure 3**. These six alternatives are

- In **Figure 3a** a single EM configuration with gearbox (GB) and a clutch is shown. It consists of an EM, a clutch (C), a gearbox, and a differential (D). The clutch enables the connection or disconnection of power flow from EM to the wheels. The gear consists of a set of gears with different gear ratios. With the use of clutch and gearbox, the driver can shift the gear ratios and hence the torque going to the wheels can be changed. The wheels have high torque low speed in the lower gears and high-speed low torque in the higher gears.

- In **Figure 3b** a single EM configuration without the gearbox and the clutch is shown. The advantage of this configuration is that the weight of the transmission is reduced. However, this configuration demands a more complex control of the EM to provide the necessary torque to the wheels.
- **Figure 3c** shows a configuration of EV using one EM. It is a transverse front EM front wheel drive configuration. It has a fixed gearing and differential and they are integrated into a single assembly.
- In **Figure 3d** a dual motor configuration is shown. In this configuration the differential action of an EV when cornering can be electronically provided by two electric motors.
- In order to shorten the mechanical transmission path from the EM to the driving wheel, the EM can be placed inside a wheel. This configuration is called in-wheel drive. **Figure 3e** shows this configuration in which fixed planetary gearing is employed to reduce the motor speed to the desired wheel speed.
- In **Figure 3f** an EV configuration without any mechanical gearing is shown. By fully abandoning any mechanical gearing, the in-wheel drive can be realized by installing a low speed outer-rotor electric motor inside a wheel.

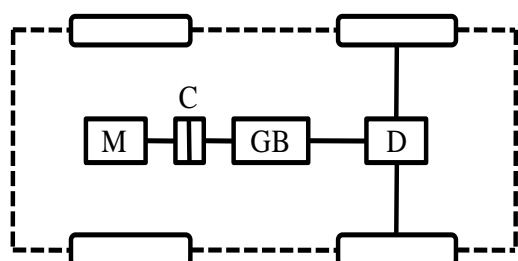

Figure 3a: EV configuration with clutch, gearbox and differential [1]

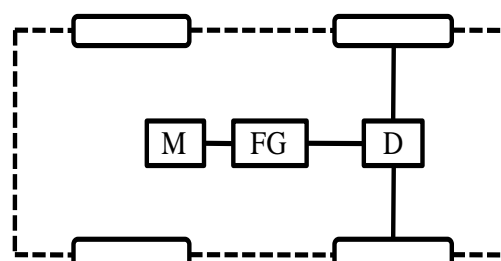

Figure 3b: EV configuration without clutch and gearbox [1]

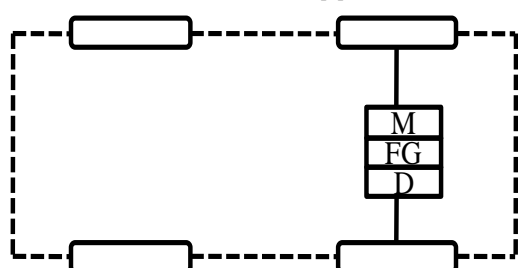

Figure 3c: EV configuration with clutch, gearbox and differential [1]

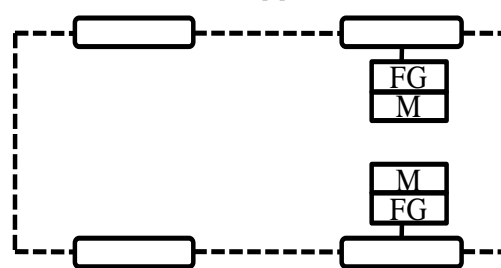

Figure 3d: EV configuration with two EM [1]

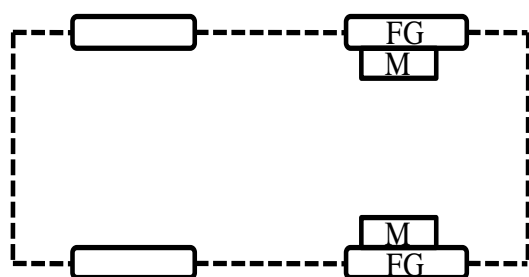

Figure 3e:EV configuration with in wheel motor and mechanical gear [1]

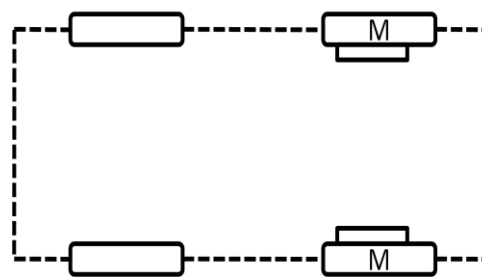

Figure 3f:EV configuration with in wheel motor and no mechanical gear [1]

C: Clutch
D: Differential
FG: Fixed gearing

GB: Gearbox
EM: Electric motor

Electric Vehicle (EV) Drivetrain Alternatives Based on Power Source Configuration

Besides the variations in electric propulsion, there are other EV configurations due to variations in energy sources. There are five configurations possible and they are:

- **Configuration 1:** It is a simple battery powered configuration, **Figure 4a**. The battery may be distributed around the vehicle, packed together at the vehicle back or located beneath the vehicle chassis. The battery in this case should have reasonable specific energy and specific power and should be able to accept regenerative energy during braking. In case of EVs, the battery should have both high specific energy and specific power because high specific power governs the driving range while the high power density governs the acceleration rate and hill climbing capability.
- **Configuration 2:** Instead of two batteries, this design uses two different batteries, **Figure 4b**. One battery is optimized for high specific energy and the other for high specific power.
- **Configuration 3:** In this arrangement fuel cell is used, **Figure 4c**. The battery is an energy storage device, whereas the fuel cell is an energy generation device. The operation principle of fuel cells is a reverse process of electrolysis. In reverse and electrolysis, hydrogen and oxygen gases combine to form electricity and water. The hydrogen gas used by the fuel cell can be stored in an on-board tank whereas oxygen gas is extracted from air. Since fuel cell can offer high specific energy but cannot accept regenerative energy, it is preferable to combine it with battery with high specific power and high-energy receptivity.

- **Configuration 4:** Rather than storing it as a compressed gas, a liquid or a metal hydride, hydrogen can be generated on-board using liquid fuels such as methanol, **Figure 4d**. In this case a mini reformer is installed in the EV to produce necessary hydrogen gas for the fuel cell.
- **Configuration 5:** In fuel cell and battery combination, the battery is selected to provide high specific power and high-energy receptivity. In this configuration a battery and supercapacitor combination is used as an energy source, **Figure 4e**. The battery used in this configuration is a high energy density device whereas the supercapacitor provides high specific power and energy receptivity. Usually, the supercapacitors are of relatively low voltage levels, an additional dc-dc power converter is needed to interface between the battery and capacitor terminals.

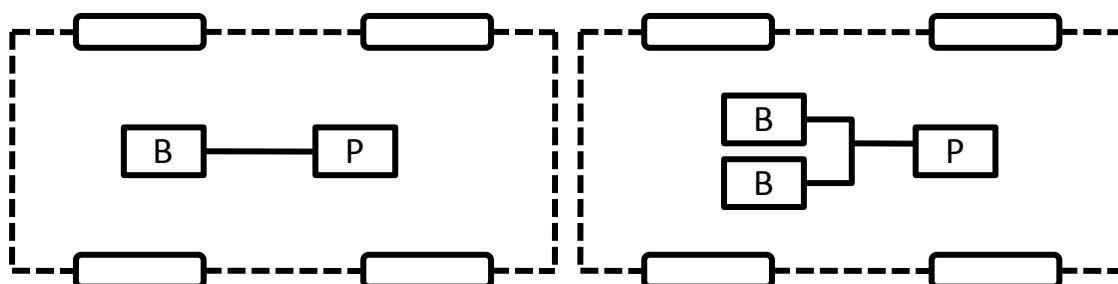

Figure 4a: EV configuration with battery source [1]

Figure 4b: EV configuration with two battery sources [1]

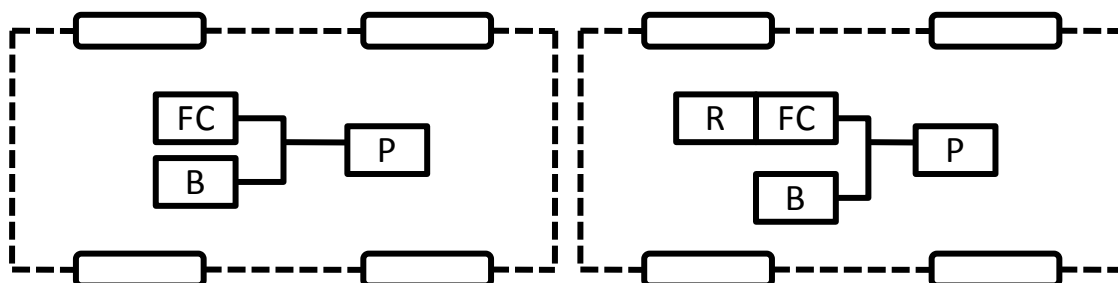

Figure 4c: EV configuration with battery and fuel cell sources [1]

Figure 4d: EV configuration with multiple energy sources [1]

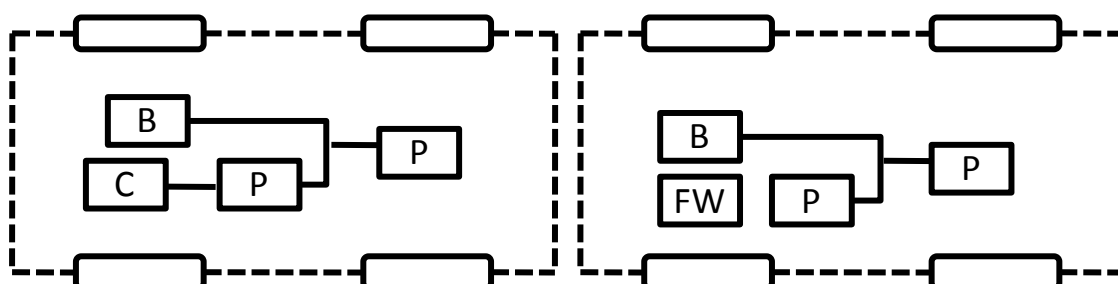

Figure 4e: EV configuration with battery and capacitors sources [1]

Figure 4f: EV configuration with battery and flywheel sources [1]

B: Battery
C: Capacitor
FC: Fuel cell

FW: Flywheel
P: Power converter
R: Reformer

Single and Multi-motor Drives

A differential is a standard component for conventional vehicles. When a vehicle is rounding a curved road, the outer wheel needs to travel on a larger radius than the inner wheel. Thus, the differential adjusts the relative speeds of the wheels. If relative speeds of the wheels are not adjusted, then the wheels will slip and result in tire wear, steering difficulties and poor road holding. In case of EVs, it is possible to dispense the mechanical differential by using two or even four EMs. With the use of multiple EMs, each wheel can be coupled to an EM and this will enable independent control of speed of each wheel in such a way that the differential action can be electronically achieved. In **Figure 5**, a typical dual motor drive with an electronic differential is shown.

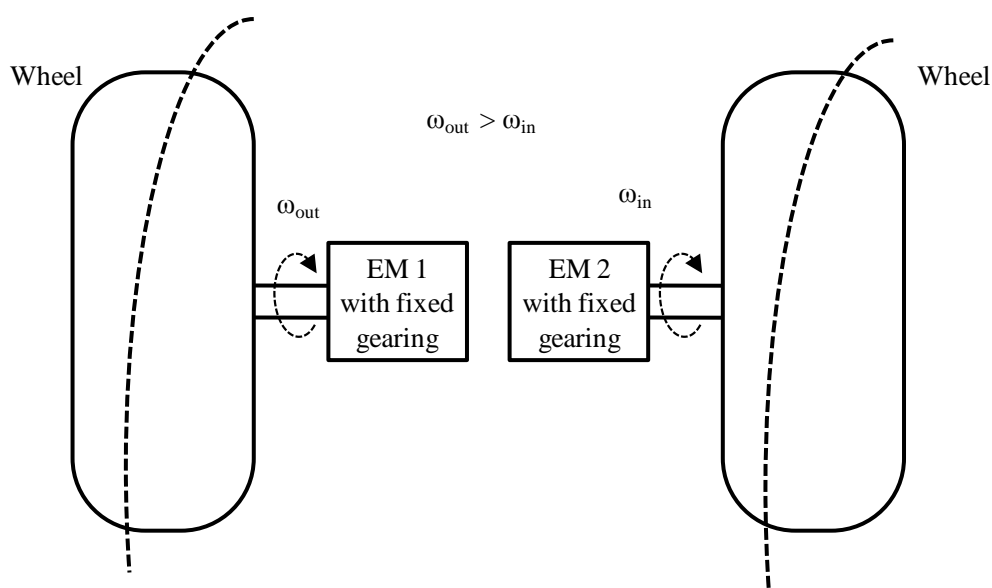

Figure 5: Differential action [1]

In Wheel Drives

By placing an electric motor inside the wheel, the in wheel motor has the advantage that the mechanical transmission path between the electric motor and the wheel can be minimized. Two possible configurations for in wheel drives are:

- When a high-speed inner-rotor motor is used (**Figure 6a**) then a fixed speed-reduction gear becomes necessary to attain a realistic wheel speed. In general, speed reduction is achieved using a planetary gear set. This planetary gear is mounted between the motor shaft and the wheel rim. Usually this motor is designed to operate up to 1000 rpm so as to give high power density.
- In case outer rotor motor is used (**Figure 6b**), then the transmission can be totally removed and the outer rotor acts as the wheel rim and the motor speed is equivalent to the wheel speed and no gears are required.

The tradeoffs of the high-speed inner rotor motor are:

- It has the advantage of smaller size, lighter weight and lower cost
- Needs additional planetary gearset

The tradeoffs of outer-rotor motor are

- Low speed and hence does not need additional gears
- The drawbacks are larger size, weight and cost because of the low speed design.

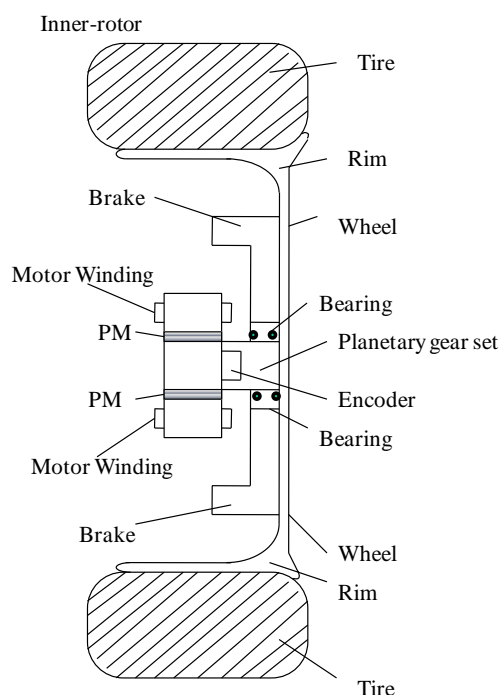

Figure 6a: Inner rotor *In Wheel* drive [1]

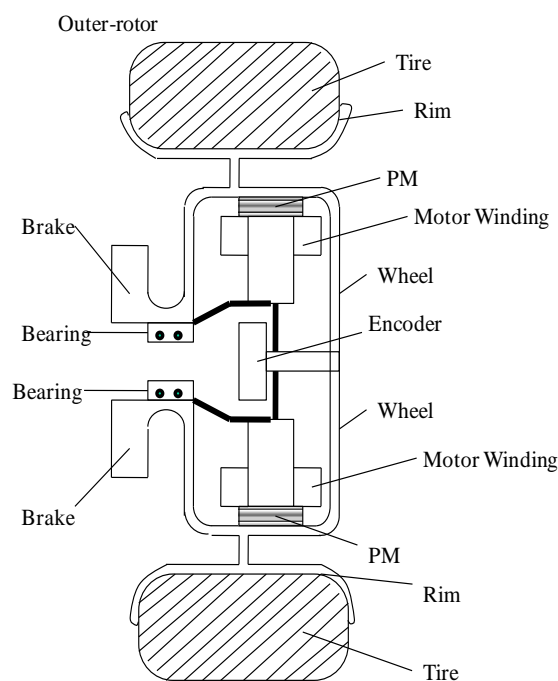

Figure 6b: Outer rotor *In Wheel* drive [1]

Considerations of EMs used in EVs

The requirements of EMs used in EVs are:

- Frequent start/stop
- High rate of acceleration and deceleration
- High torque low speed hill climbing
- Low torque cruising
- Very wide speed range of operation

The EMs for EVs are unique and their major differences with respect to industrial motors in load requirement, performance specification and operating environment are as follows:

- EV motors need to produce the maximum torque that is four to five times of the rated torque for acceleration and hill climbing, while industrial motors generally offer the maximum torque that is twice of the rated torque for overload operation
- EV motors need to achieve four to five times the base speed for highway cruising, while industrial motors generally achieve up to twice the base speed for constant power operation
- EV motors require high power density as well as good efficiency map (high efficiency over wide speed and torque ranges), while industrial motors are generally optimized to give high efficiency at a rated point.
- EV motors need to be installed in mobile vehicles with harsh operating conditions such as high temperature, bad weather and frequent vibration, while industrial motors are generally located in fixed places.

References:

[1] C. C. Chan and K. T. Chau, *Modern Electric Vehicle Technology*, Oxford Science Publication, 2001

Suggested Reading:

[1] I. Husain, *Electric and Hybrid Electric Vehicles*, CRC Press, 2003

[2] M. Ehsani, *Modern Electric, Hybrid Electric and Fuel Cell Vehicles: Fundamentals, Theory and Design*, CRC Press, 2005